

ZQ1 BLOCK DIAGRAM

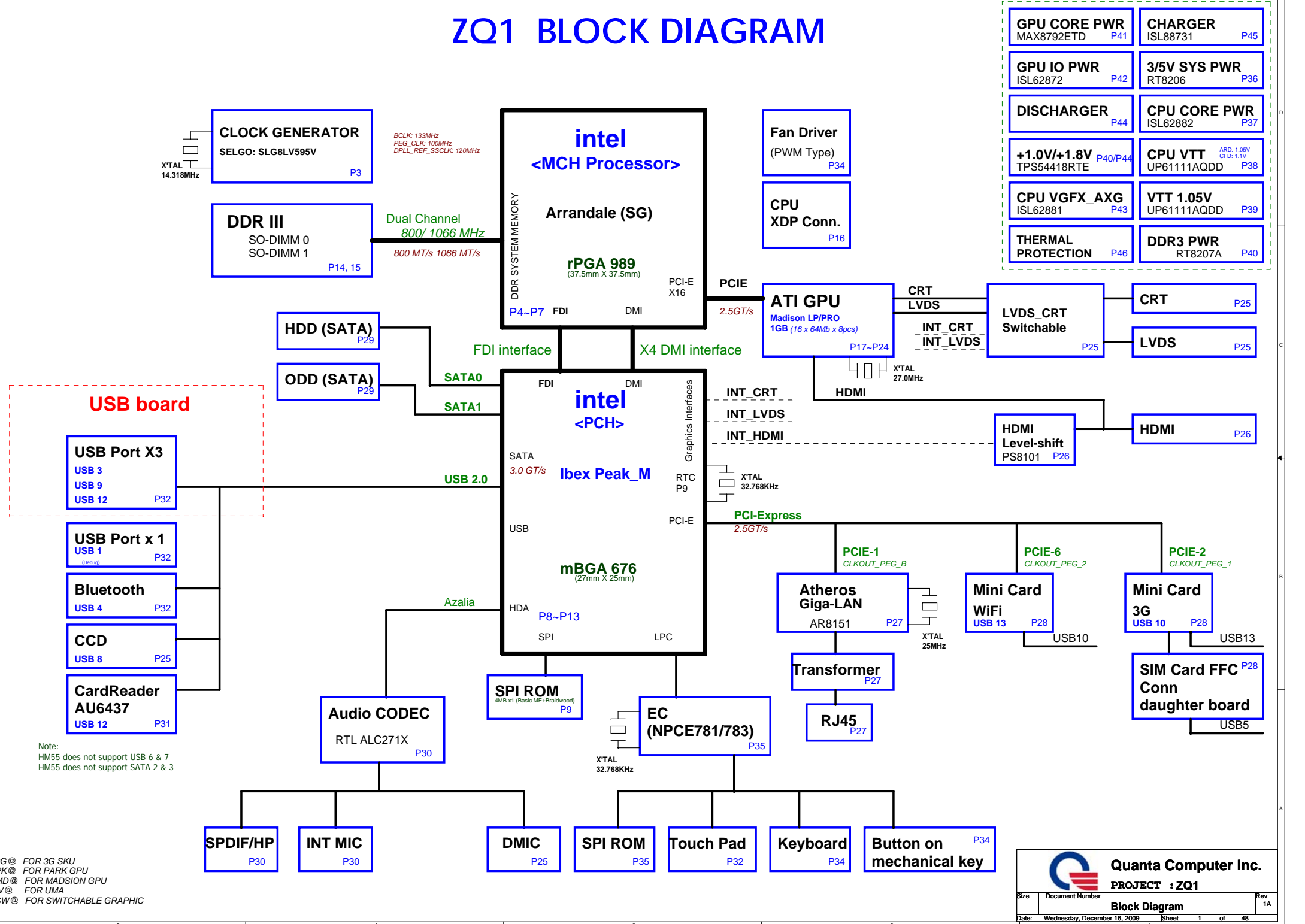

GPU CORE PWR MAX8792ETD P41	CHARGER ISL88731 P45
GPU IO PWR ISL62872 P42	3/5V SYS PWR RT8206 P36
DISCHARGER P44	CPU CORE PWR ISL62882 P37
+1.0V/+1.8V TPS54418RTE P40/P44	CPU VTT UP61111AQDD P38 <small>ARD: 1.05V CFD: 1.1V</small>
CPU VGFX_AXG ISL62881 P43	VTT 1.05V UP61111AQDD P39
THERMAL PROTECTION P46	DDR3 PWR RT8207A P40

3G@ FOR 3G SKU
 PK@ FOR PARK GPU
 MD@ FOR MADSION GPU
 IV@ FOR UMA
 SW@ FOR SWITCHABLE GRAPHIC

GPU PWR CTRL Option 1 (Default/ VDDR3 before VDDC)

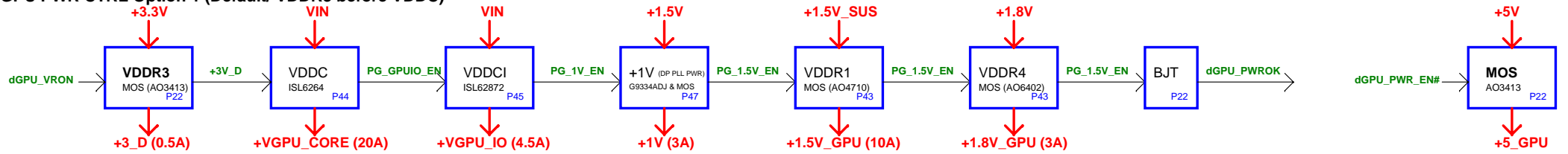

GPU PWR CTRL Option 2 (VDDR3 after VDDR1)

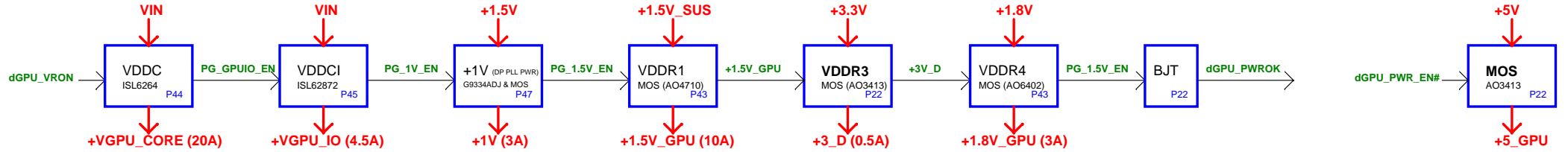

Power States

POWER PLANE	VOLTAGE	DESCRIPTION	CONTROL SIGNAL	ACTIVE IN
VIN	+10V~+19V	MAIN POWER		S0-S5
+RTC_CELL	+3V~+3.3V	RTC		S0-S5
+3VPCU	+3.3V	8051 POWER	ALWON	S0-S5
+5VPCU	+5V	CHARGE POWER	ALWON	S0-S5
+15V	+15V	LARGE POWER	+15V_ALWP	S0-S5
3V_LAN_S5	+3.3V	LAN POWER	AUX_ON	
+5VSUS	+5V		SUSD	
+3VSUS	+3.3V		SUSD	
+1.5V_SUS	+1.5V	SODIMM POWER	SUSON	
+0.75V_DDR_VTT	+0.9V	SODIMM POWER	MAINON	
+5V	+5V		MAIND	
+3V	+3.3V		MAIND	
+1.8V	+1.8V		MAINON	
+1.5V	+1.5V	PCH POWER	MAIND	
+1.1V_VTT	+1.05V~+1.1V	CPU POWER	MAINON	
+1.05V	+1.05V	PCH POWER	MAINON	
+VCC_CORE	0V~+1.5V	CPU CORE POWER	VRON	
LCDVCC	+3.3V	LCD Power	LVDS_VDDEN	
MBAT+	+10V~+17V	MAIN BATTERY		
+5V_S5	+5V		S5_ON	
+3V_S5	+3.3V		S5D	

Thermal Follow Chart

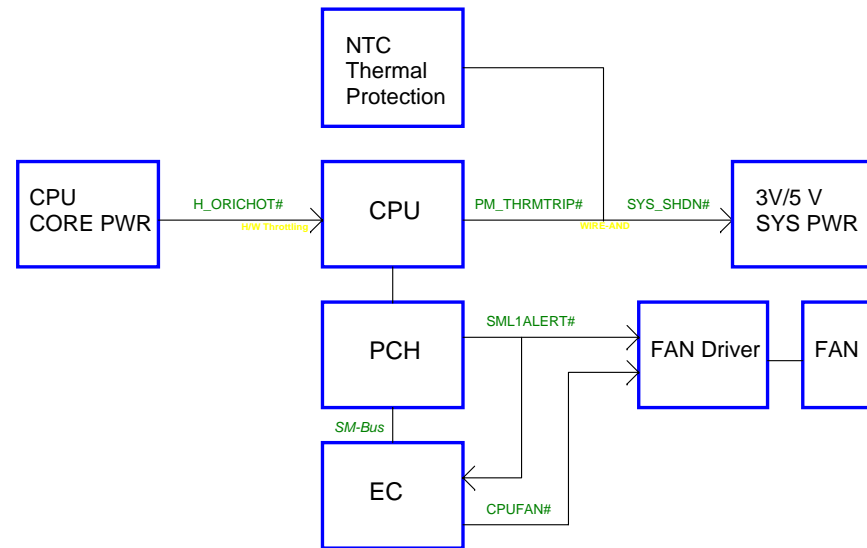

CLK Gen(CLK)

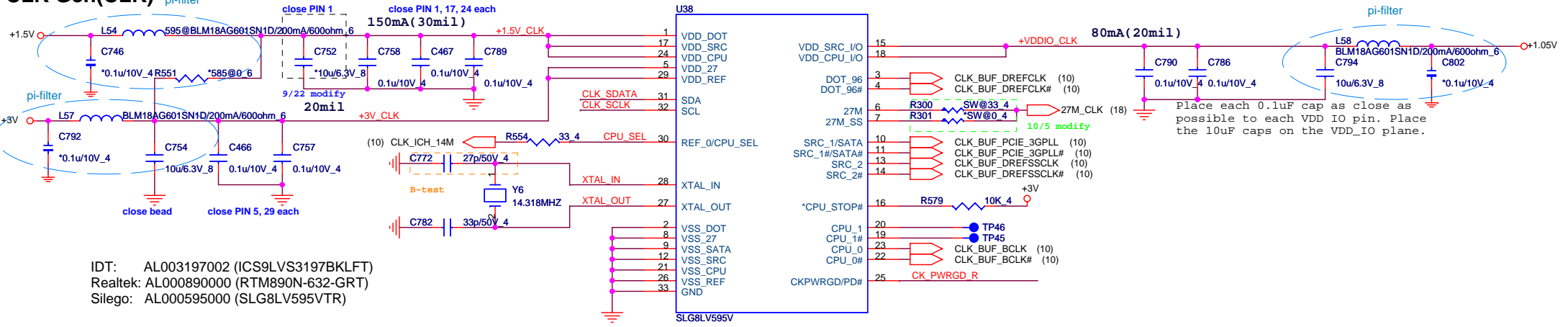

CPU_CLK select(CLK)

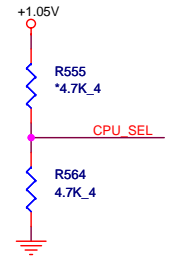

	0	1
CPU_SEL	CPU0/1=133MHz (default)	CPU0/1=100MHz

SMBus(CLK)

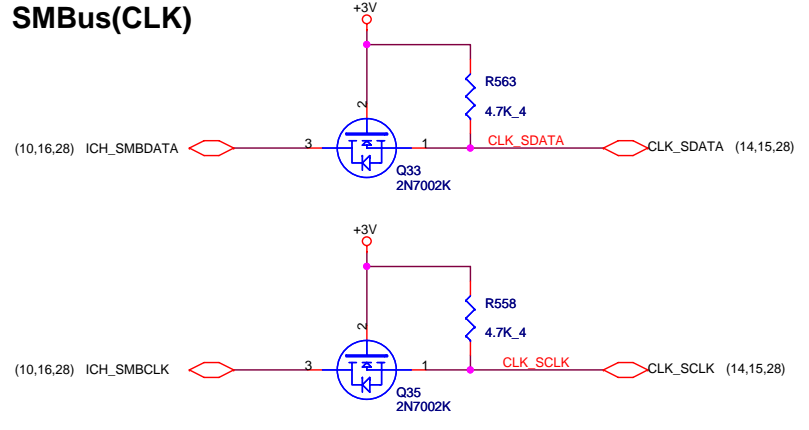

CLK Enable(CLK)

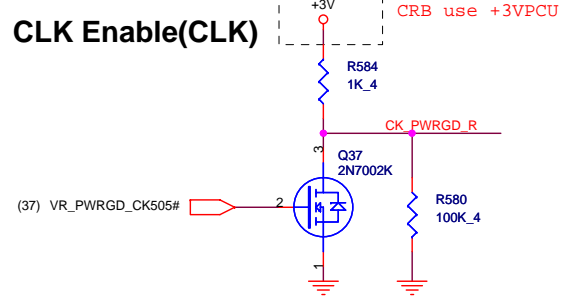

Quanta Computer Inc.
PROJECT : ZQ1

Size	Document Number	Rev
	Clock Generator	1A
Date:	Friday, January 22, 2010	Sheet 3 of 48

AUBURNDALE/CLARKSFIELD PROCESSOR (DMI, PEG, FDI)

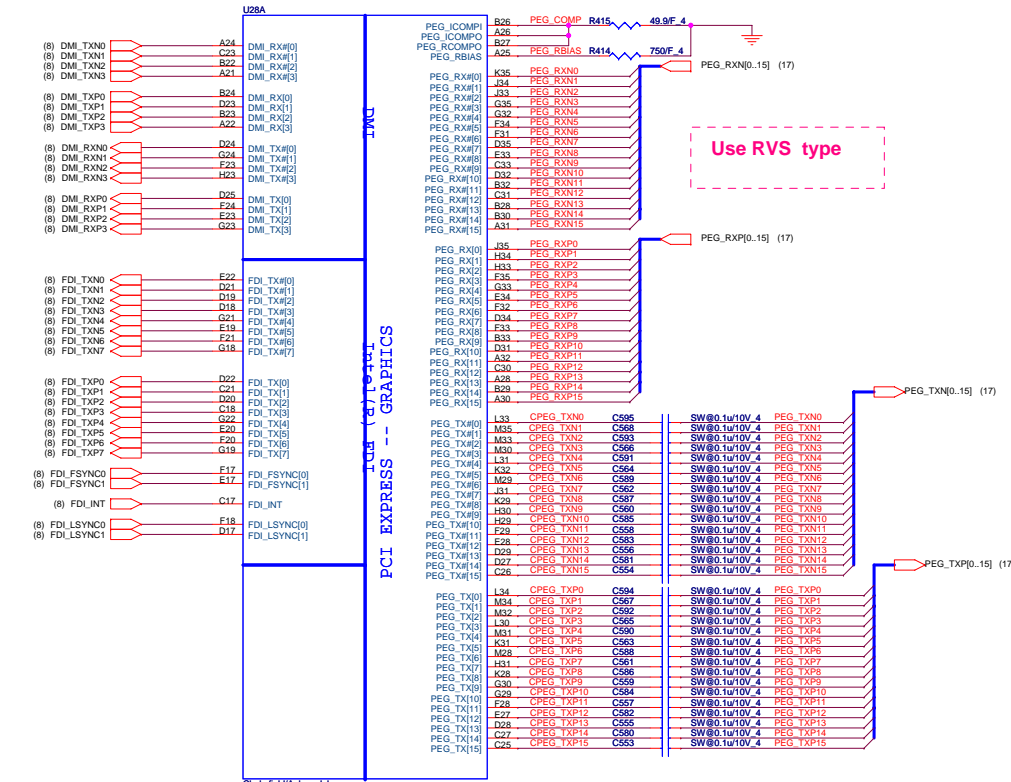

Processor Compensation Signals

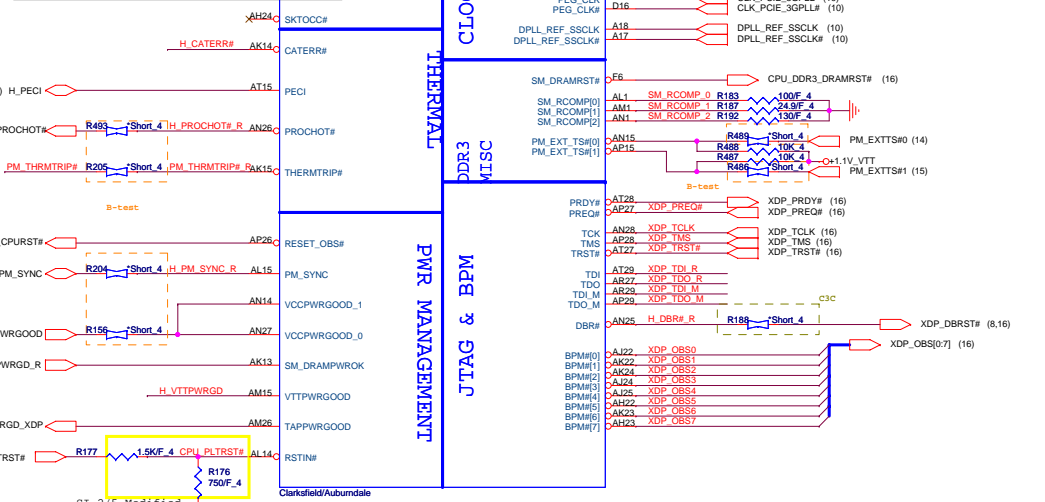
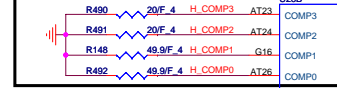

	STD
FOX	DGG*9000024
LTS	DGG*9000022
SUY	
MLX	
Standard: rpga989-aca-zif-069-k01-socket	
Reverse: PZ98927-364R-01F-SOCKET	

Thermaltrip protect(CPU)

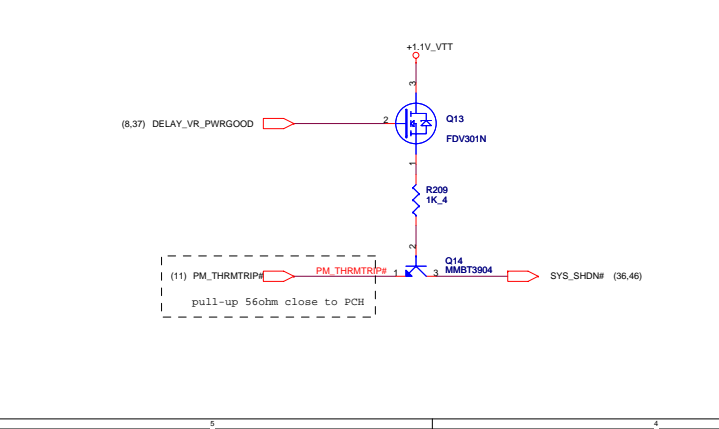

VTT PWR_Good(CPU)

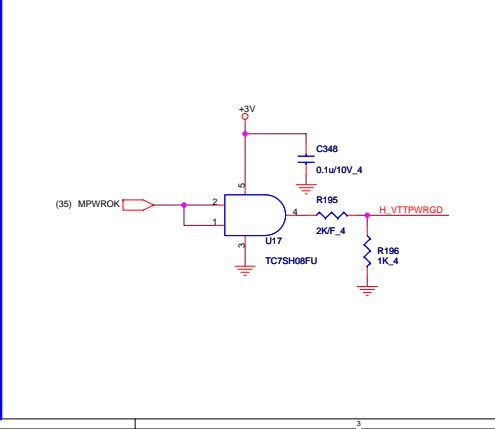

Processor pull-up(CPU)

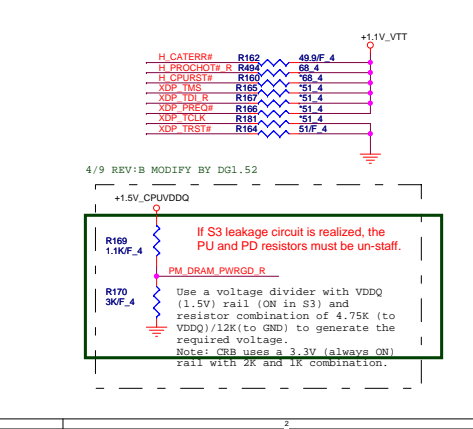

JTAG MAPPING(CPU)

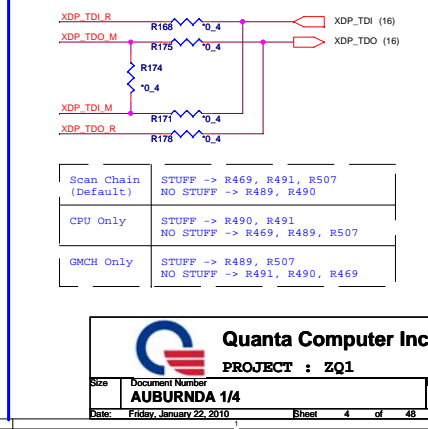

Scan Chain (Default)	STUFF -> R469, R491, R507 NO STUFF -> R489, R490
CPU Only	STUFF -> R490, R491 NO STUFF -> R469, R489, R507
GMCH Only	STUFF -> R489, R507 NO STUFF -> R491, R490, R469

Quanta Computer Inc.
PROJECT : ZQ1

Size: Document Number: AUBURNDA 1/4
Date: Friday, January 22, 2010 8:58:41 AM Page 4 of 48

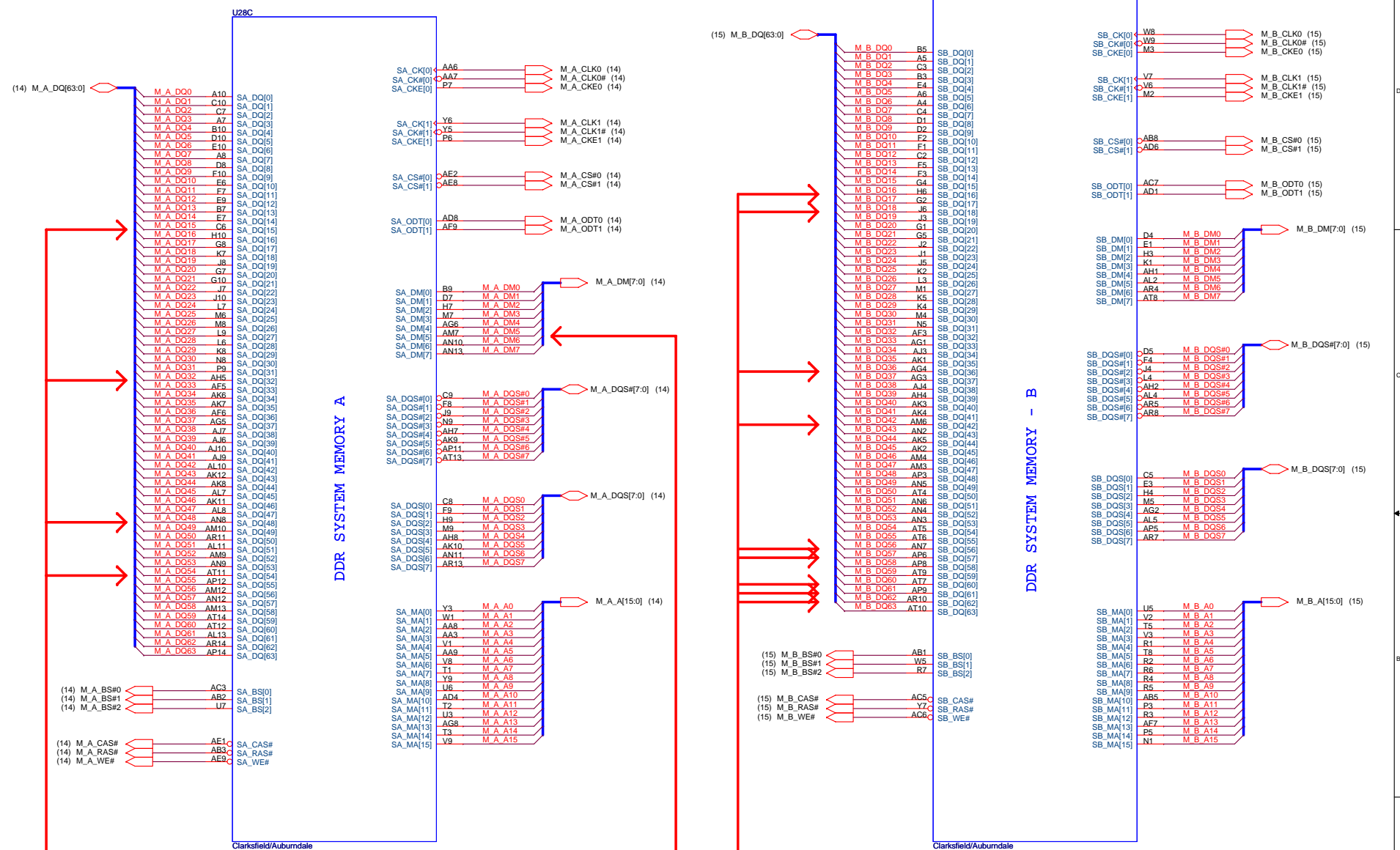

Channel A DQ[15,32,48,54], DM[5]
 Requires minimum 12mils spacing
 with all other signals, including data signals.

Channel B DQ[16,18,36,42,56,57,60,61,62]
 Requires minimum 12mils spacing
 with all other signals, including data signals.

CPU Core Power

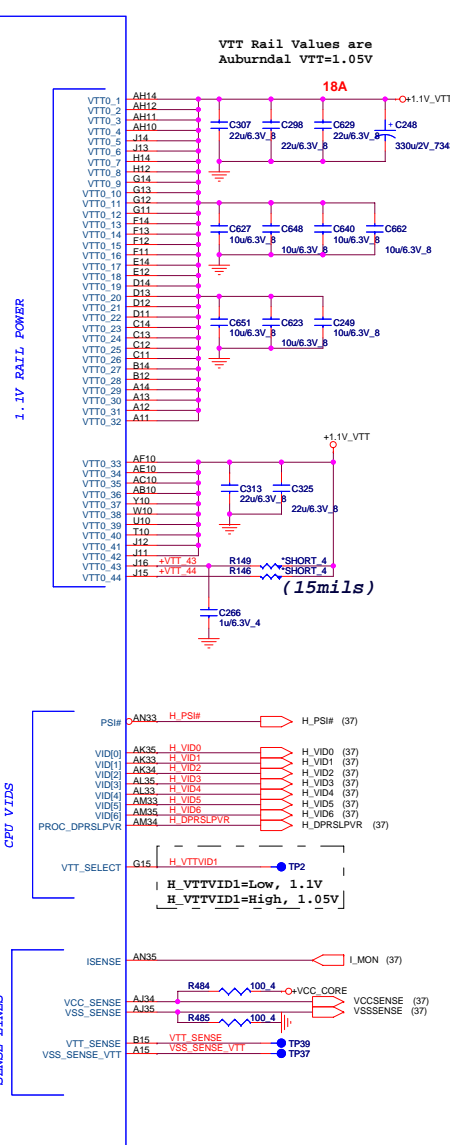
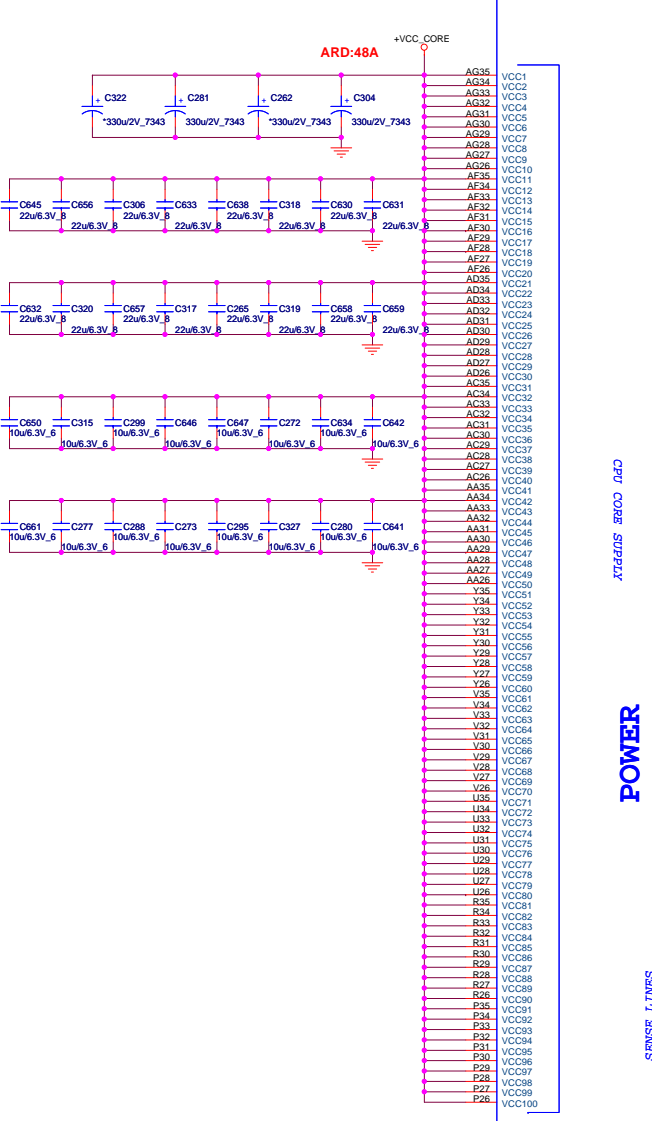

AUBURNDALE/CLARKSFIELD PROCESSOR (GRAPHICS POWER)

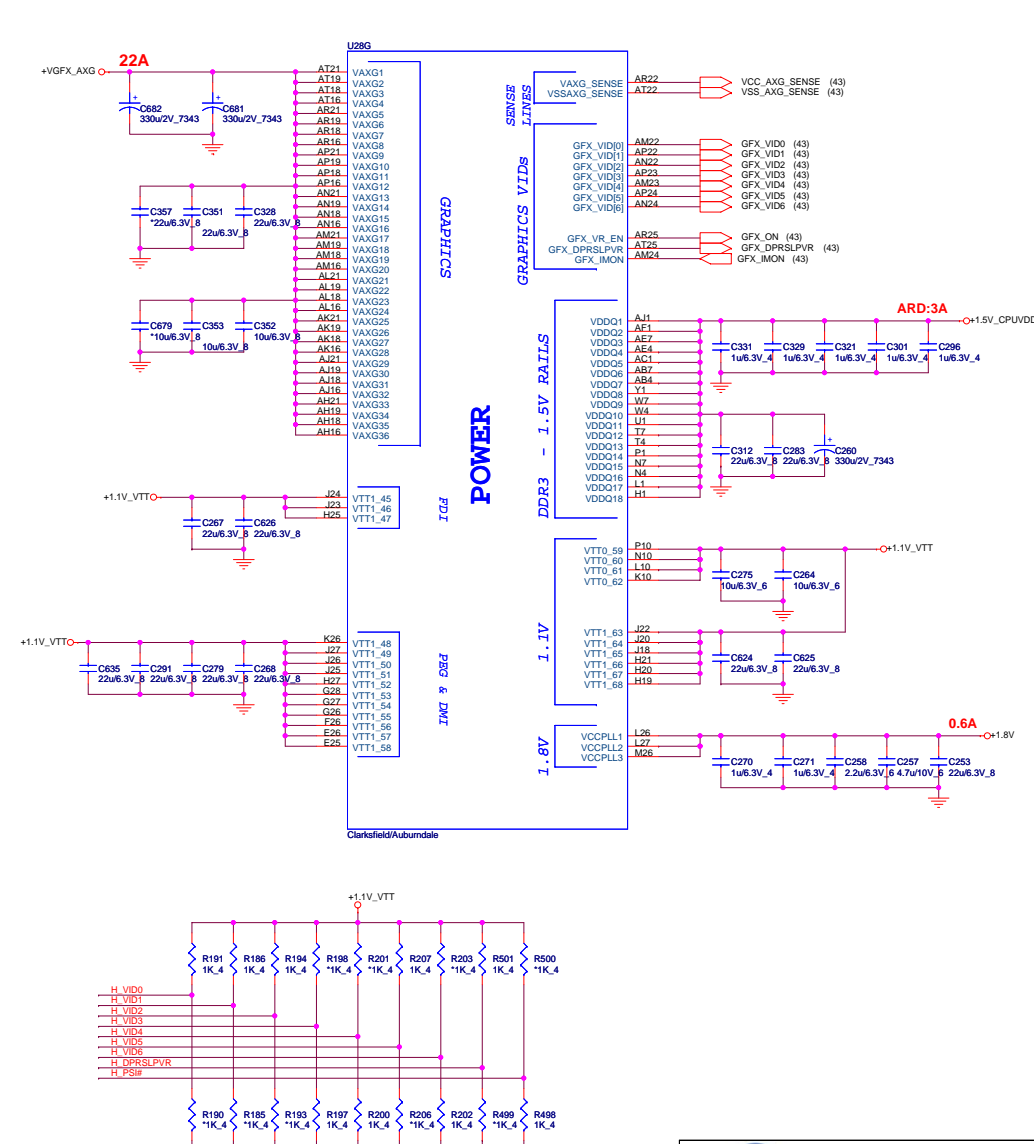

AUBURNDALE/CLARKSFIELD PROCESSOR (POWER)

NOTE:
For Validating IMV9 VR R6451 should be STUFF
and R2N1 NO_STUFF

HFM_VID : Max 1.4V
LFM_VID : Min 0.65V

Quanta Computer Inc.

PROJECT : Zq1

Size: _____ Document Number: **AUBURND 3/4 (PWR)** Rev: 1A

Date: Friday, January 22, 2010 ESheet: 6 of 48

Arrandale_4(CPU)

AUBURNDALE/CLARKSFIELD PROCESSOR (GND)

AUBURNDALE/CLARKSFIELD PROCESSOR (RESERVED, CFG)

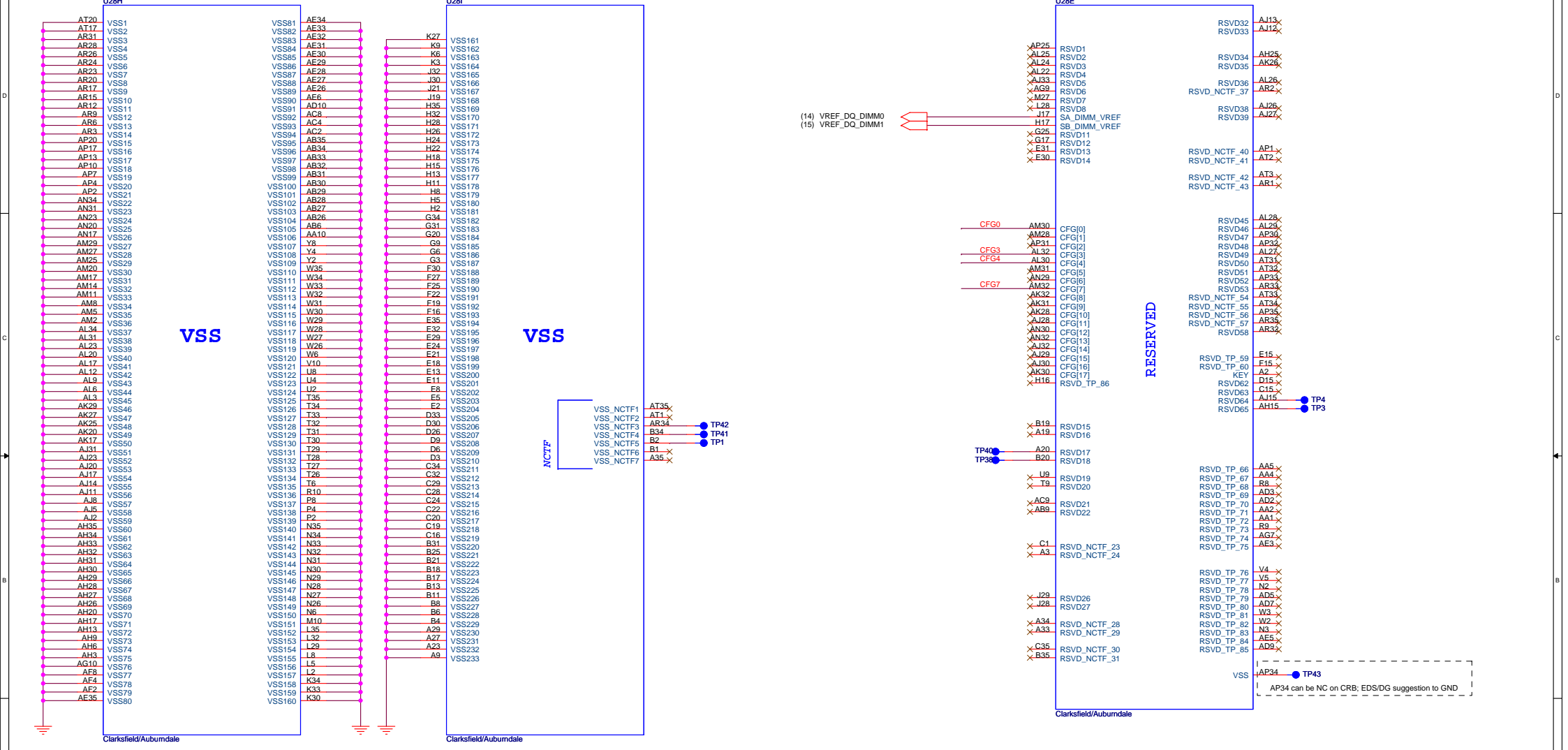

Processor Strapping

The CFG signals have a default value of '1' if not terminated on the board.

	1	0
CFG4 (Display Port Presence)	Disabled; No Physical Display Port attached to Embedded Display Port	Enabled; An external Display port device is connected to the Embedded Display port
CFG0 (PCI-Epress Configuration Select)	Single PEG	Bifurcation enabled
CFG3 (PCI-Epress Static Lane Reversal)	Normal Operation	Lane Numbers Reversed

CFG[1:0] - PCI_Epress Configuration Select
 * 11= 1 x 16 PEG
 * 10= 2 x 8 PEG

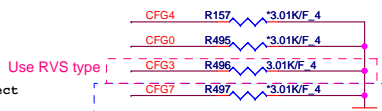

The Clarkfield processor's PCI Express interface may not meet PCI Express 2.0 jitter specifications. Intel recommends placing a 3.01K +/- 5% pull down resistor to VSS on CFG[7] pin for both rPGA and BGA components. This pull down resistor should be removed when this issue is fixed. (ES1 only)

Quanta Computer Inc.
 PROJECT : ZQ1

Size: Document Number: AUBURND4/4 Rev: 1A
 Date: Friday, January 22, 2010 Sheet: 7 of 48

PCH1 (CLG) IBEX PEAK-M (DMI, FDI, GPIO)

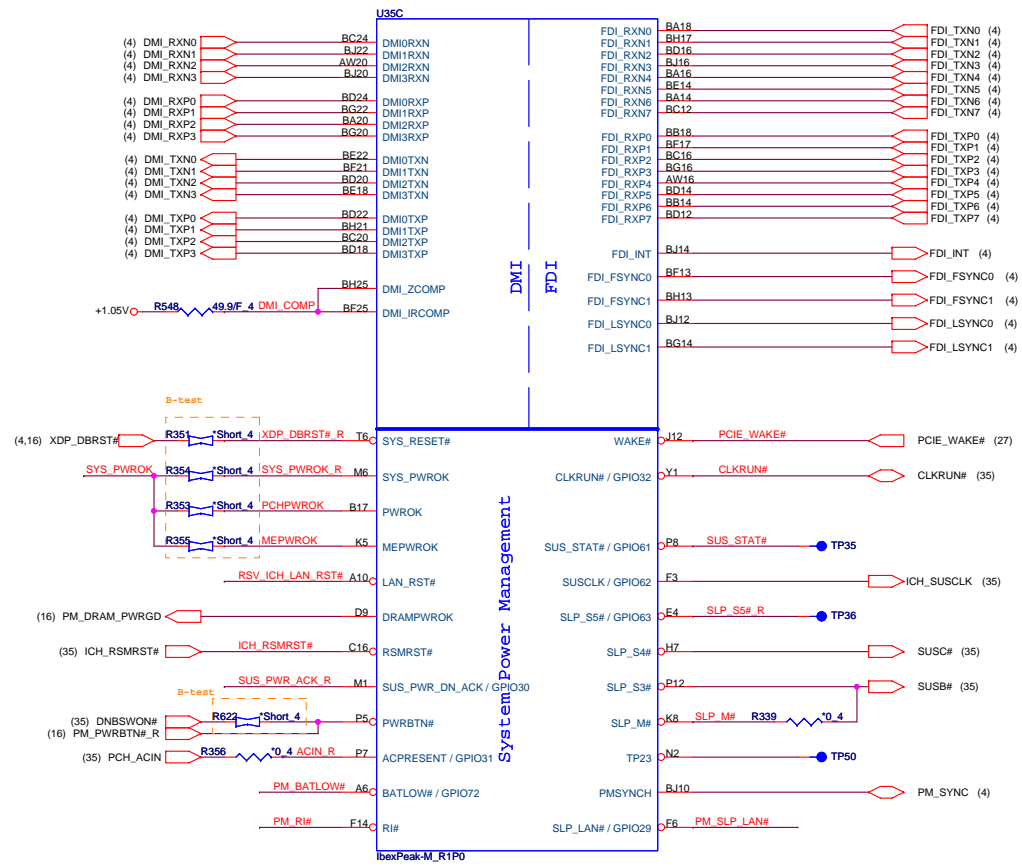

IBEX PEAK-M (LVDS, DDI)

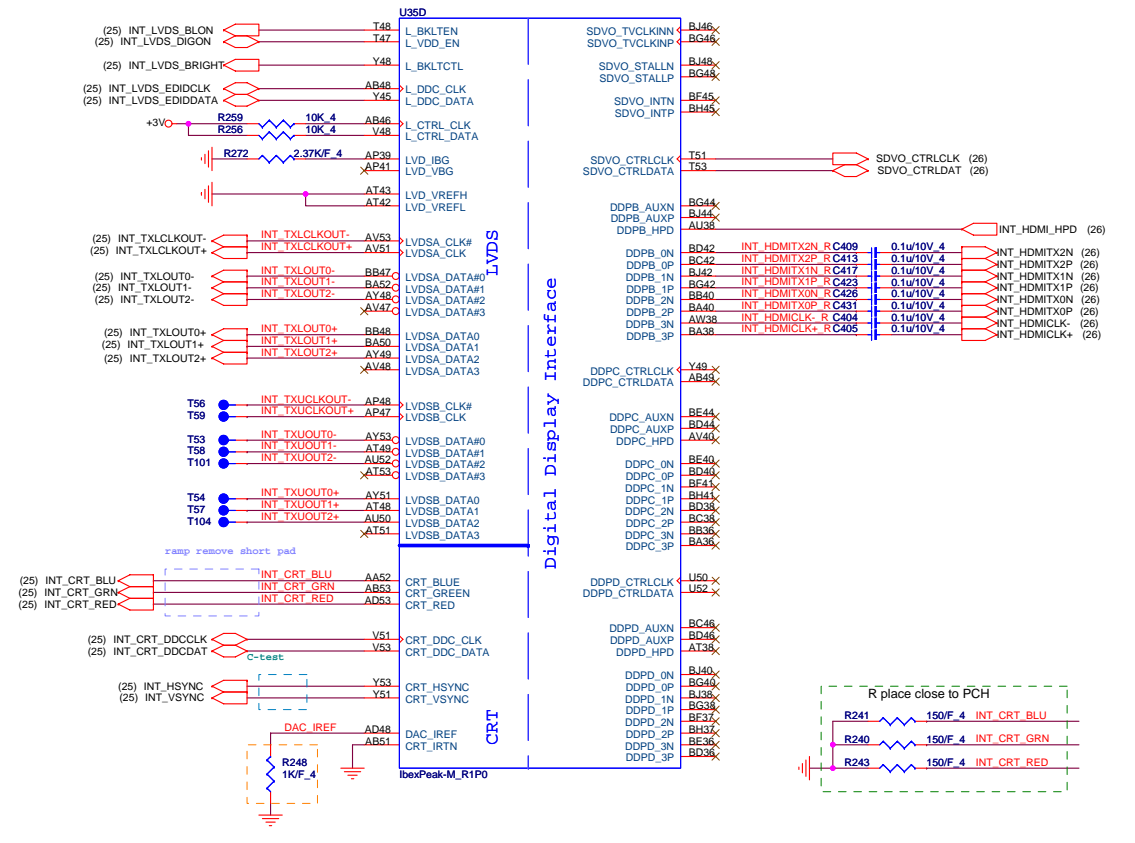

PCH Pull-high/low(CLG)

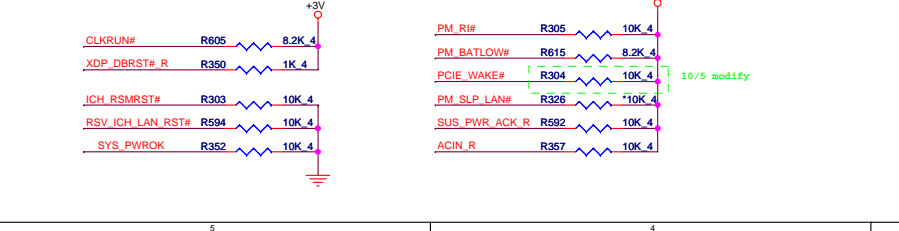

System PWR_OK(CLG)

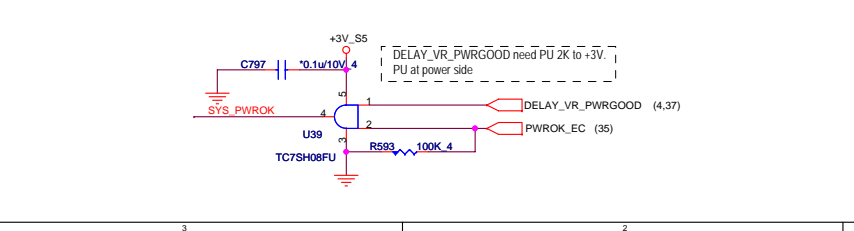

Quanta Computer Inc.

PROJECT : ZQ1

Size	Document Number	Rev
	IBEX PEAK-M /16	1A
Date:	Friday, January 22, 2010	Sheet 8 of 48

RTC Circuitry(RTC)

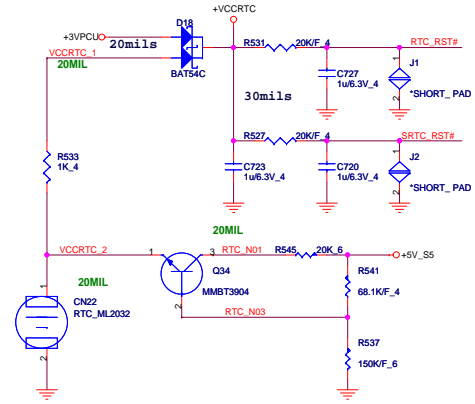

HDA Bus(CLG)

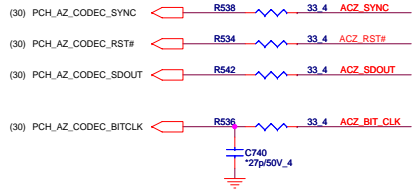

Place all series terms close to PCH except for SDIN input lines, which should be close to source. Placement of R should equal distance to the T split trace point. Basically, keep the same distance from T for all series termination resistors.

PCH SPI(CLG)

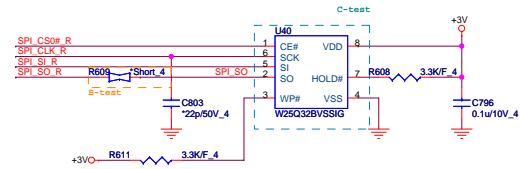

PCH2(CLG)

HDA_SYNC (PCH strap pin)
Internal weak pull-down
VCCVPM=>1.8V (default)
external pull-up
VCCVPM=>1.5V

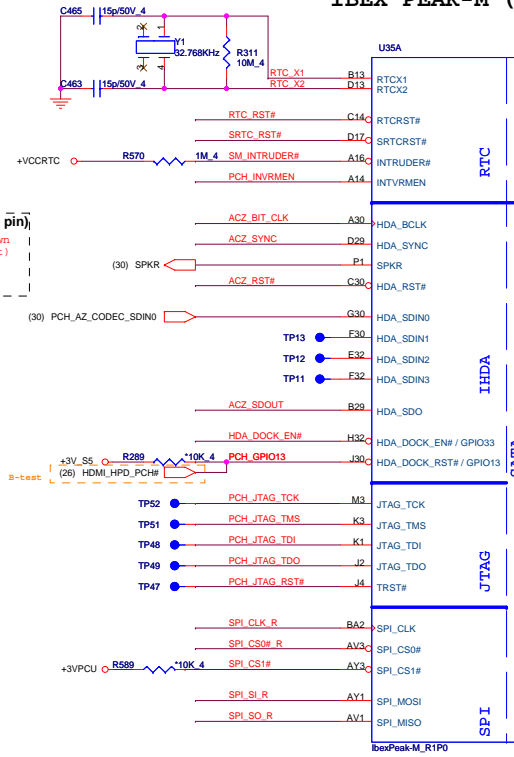

IBEX PEAK-M (HDA, JTAG, SATA)

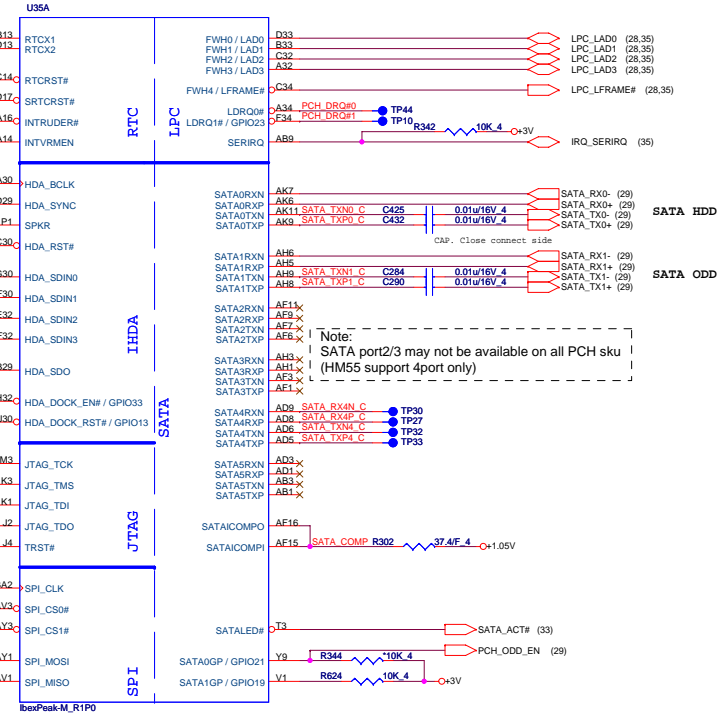

PCH Strap Table

Pin Name	Strap description	Sampled	Configuration	ZQ1 note												
SPKR	No reboot mode setting	PWROK	0 = Default (weak pull-down 20K) 1 = Setting to No-Reboot mode	+3V0 — R601 — *10K_4 — SPKR												
INIT3_3V	Reserved	PWROK	1 = Default (weak pull-up 20K) Should not be pull-down													
GNT3# / GPIO55	Top-Block Swap Override	PWROK	0 = "top-block swap" mode 1 = Default (weak pull-up 20K)	R517 — *10K_4 — PCL_GNT3# (10)												
INTRVMEN	Integrated 1.05V VRM enable	ALWAYS	Should be always pull-up	+VCCRTC — R567 — 330K_4 — PCH_INVRMEN												
GNT1# / GPIO51	Boot BIOS Selection 1 [bit-1]	PWROK	<table border="1"> <tr> <td>GNT1#</td> <td>GNT0#</td> <td>Boot Location</td> </tr> <tr> <td>1</td> <td>1</td> <td>SPI</td> </tr> <tr> <td>1</td> <td>0</td> <td>PCI</td> </tr> <tr> <td>0</td> <td>0</td> <td>LPC</td> </tr> </table>	GNT1#	GNT0#	Boot Location	1	1	SPI	1	0	PCI	0	0	LPC	Default weak pull-up on GNT0/1# [Need external pull-down for LPC BIOS]
GNT1#	GNT0#	Boot Location														
1	1	SPI														
1	0	PCI														
0	0	LPC														
GNT0#	Boot BIOS Selection 0 [bit-0]	PWROK	<table border="1"> <tr> <td>GNT1#</td> <td>GNT0#</td> <td>Boot Location</td> </tr> <tr> <td>1</td> <td>1</td> <td>SPI</td> </tr> <tr> <td>1</td> <td>0</td> <td>PCI</td> </tr> <tr> <td>0</td> <td>0</td> <td>LPC</td> </tr> </table>	GNT1#	GNT0#	Boot Location	1	1	SPI	1	0	PCI	0	0	LPC	
GNT1#	GNT0#	Boot Location														
1	1	SPI														
1	0	PCI														
0	0	LPC														
GNT2# / GPIO53	ESI strap (Server only)	PWROK	Should not be pull-down (weak pull-up 20K)	USE GPIO PIN												
NV_ALE	Intel Anti-Theft HDD protection	PWROK	0 = Disable (Internal pull-down 32ohm)	+1.8V — R590 — *1K_4 — NV_ALE — NV_ALE (10)												
NV_CLE	DMI Termination voltage	PWROK	weak pull-down 32ohm	+1.8V — R591 — *1K_4 — NV_CLE — NV_CLE (10)												
HDA_DOCK_EN#/GPIO33	Flash Descriptor Security	PWROK	0 = Override 1 = Default (weak pull-up 20K)	+3V0 — R277 — *1K_4 — HDA_DOCK_EN# +3V0 — R273 — *10K_4 — HDA_DOCK_EN#												
SPI_MOSI	iTPM function Disable	MEPWROK	0 = Default (weak pull-down 20K) 1 = Enable	+3V0 — R627 — *1K_4 — SPI_SI_R												
HDA_SDO	Reserved	RSMRST#	Should not be pull-up (weak pull-down 20K)													
GPIO8	Reserved	RSMRST#	Should not be pull-down (weak pull-up 20K)													
GPIO27	On-die PLL Voltage Regulator	RSMRST#	0 = Disable 1 = Enable (weak pull-up 20K)	+3V_S5 — R340 — *10K_4 — RV_S_GPIO8 (11)												
HDA_SYNC	On-die PLL PWR supply select	RSMRST#	0 = 1.8V supply (weak pull-down 20K) 1 = 1.5V supply	use default (0 = 1.8V supply)												
GPIO15	Reserved	RSMRST#	0 = TLS no Confidentiality (weak pull-down 20K) 1 = TLS Confidentiality	+3V_S5 — R349 — *1K_4 — CR_WAKE# (11)												

IBEX PEAK-M (PCI,USB,NVRAM)



IBEX PEAK-M (PCI-E, SMBUS, CLK)

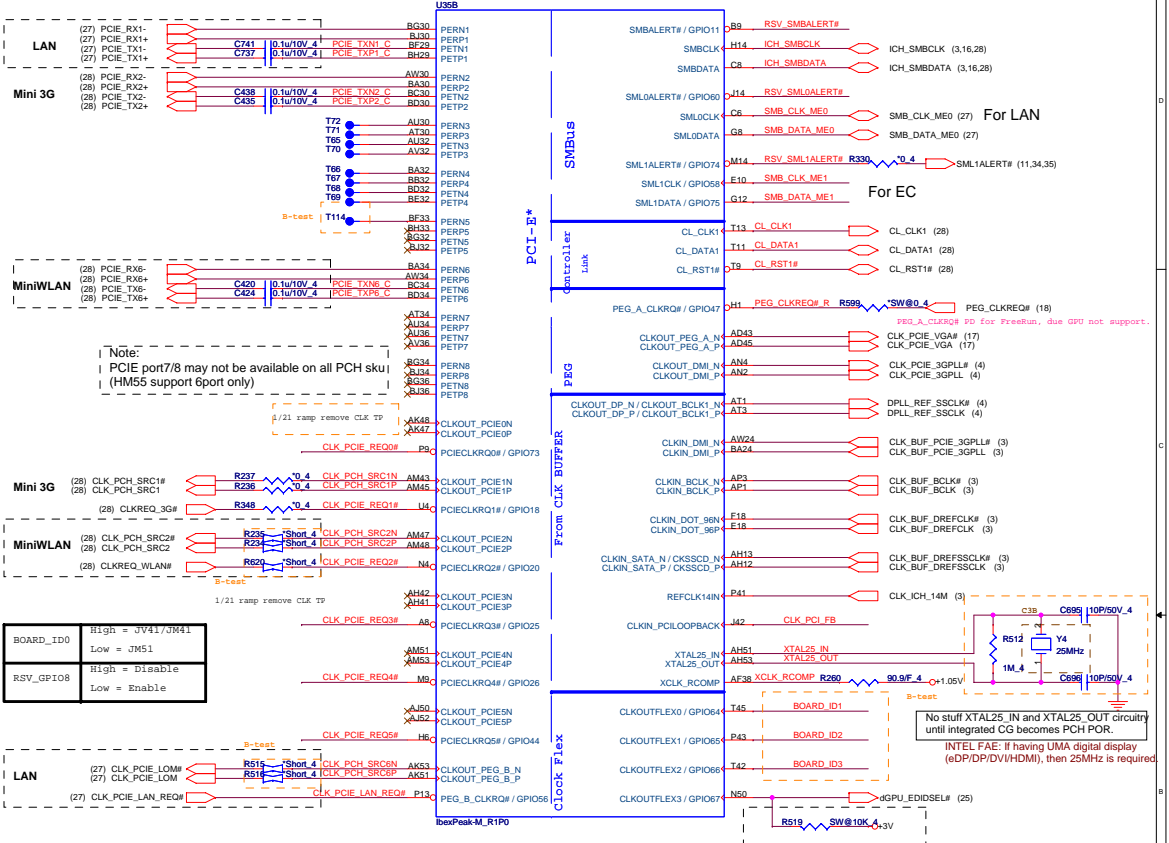

PLTRST#(CLG)

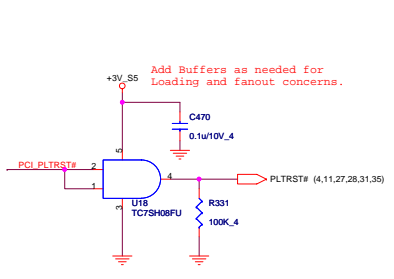

PCI/USBOC# Pull-up(CLG)

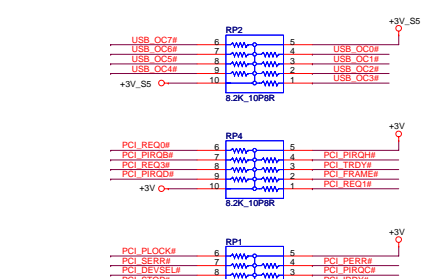

CLK_REQ/Strap Pin(CLG)

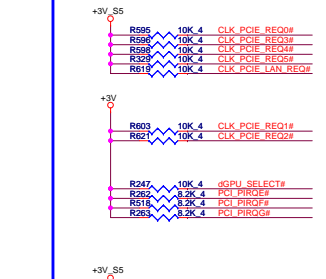

A16 swap override Strap/Top-Block Swap Override jumper

Low = A16 swap override/Top-Block Swap override enabled
High = Default

Boot BIOS Strap

GN1#	GN1#	Boot BIOS Location
0	0	LRC
0	1	Reserved (NAND)
1	0	PCI
1	1	SPI

Danbury Technology Enabled

NV_ALE High = Enable
Low = Disable

DMI Termination Voltage

NV_CLE Set to Vcc when LOW
Set to Vcc/2 when HIGH

SMBUS/Pull-up(CLG)

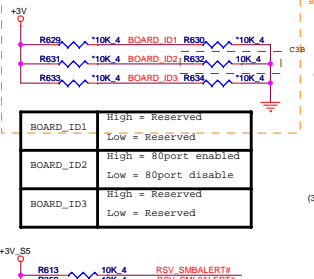

Quanta Computer Inc.

PROJECT : ZQ1

Size Document Number
IBEX PEAK-M 3/6

Date: Friday, January 22, 2010 Sheet 10 of 48

PCH4 (CLG)

IBEX PEAK-M (GPIO,VSS_NCTF,RSVD)

GPU RST#(CLG)

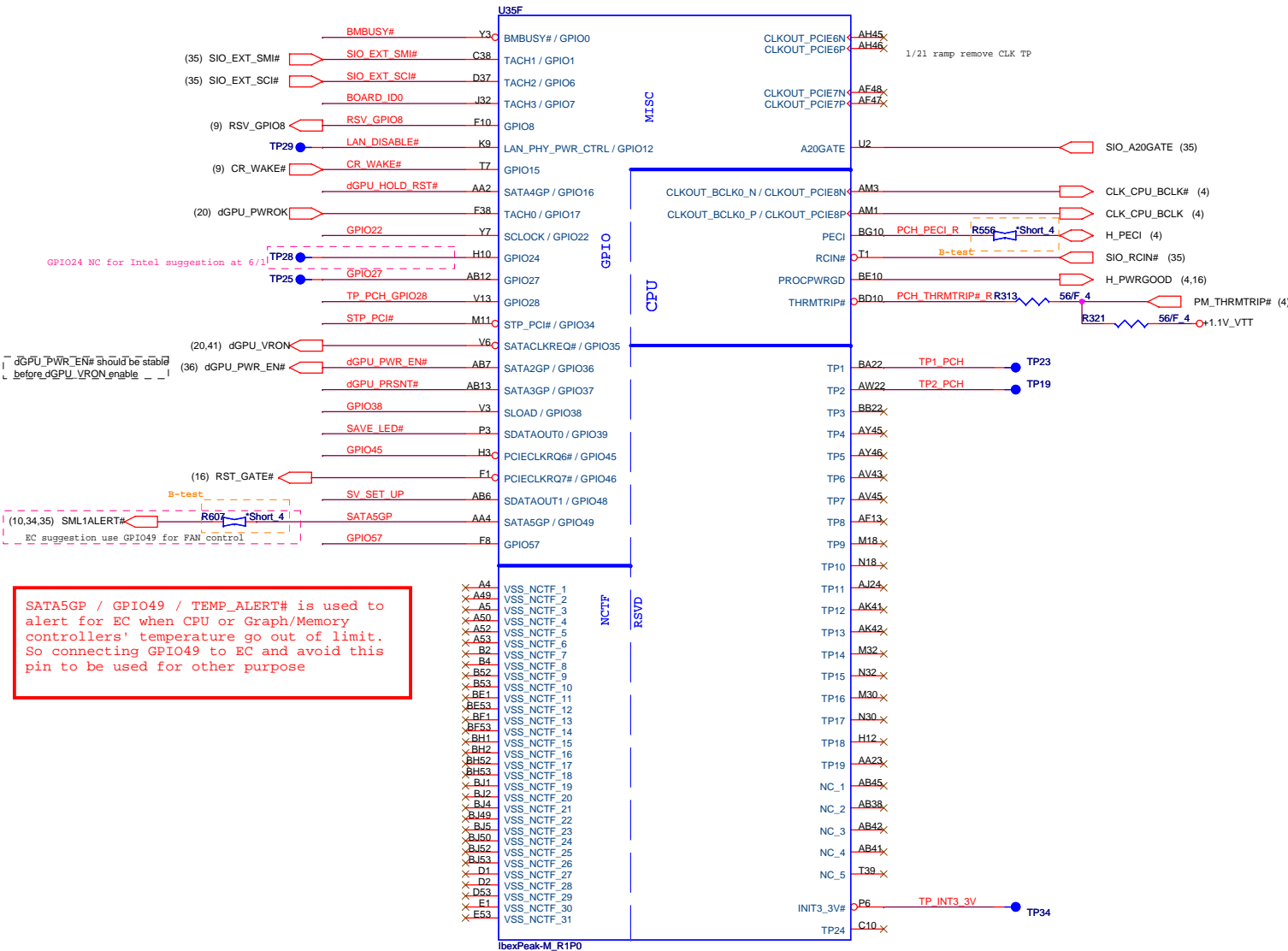

SATA5GP / GPIO49 / TEMP_ALERT# is used to alert for EC when CPU or Graph/Memory controllers' temperature go out of limit. So connecting GPIO49 to EC and avoid this pin to be used for other purpose

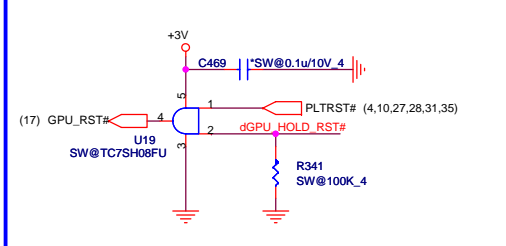

GPIO Pull-up/Pull-down(CLG)

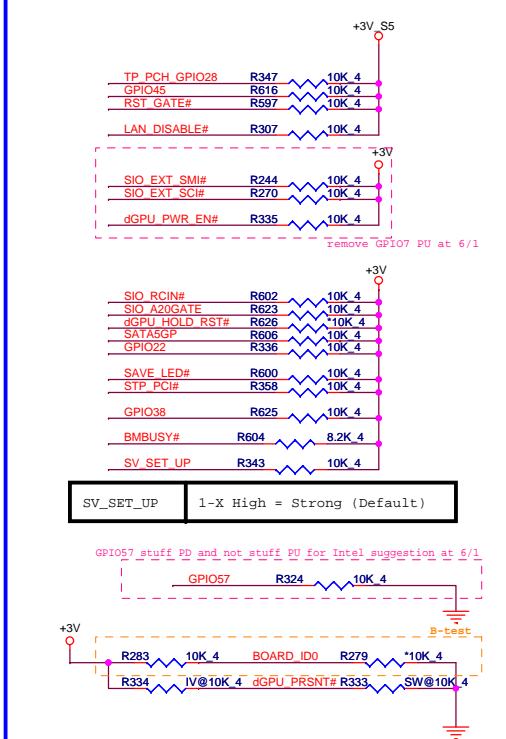

SV_SET_UP 1-X High = Strong (Default)

BOARD_ID0	High = JV41/JM41 Low = JM51
RSV_GPIO8	High = Disable Low = Enable

Quanta Computer Inc.
PROJECT : ZQ1

Size	Document Number	Rev
	IBEX PEAK-M 4/6	1A
Date:	Friday, January 22, 2010	Sheet 11 of 48

PCH5 (CLG)

IBEX PEAK-M (POWER)

POWER

POWER

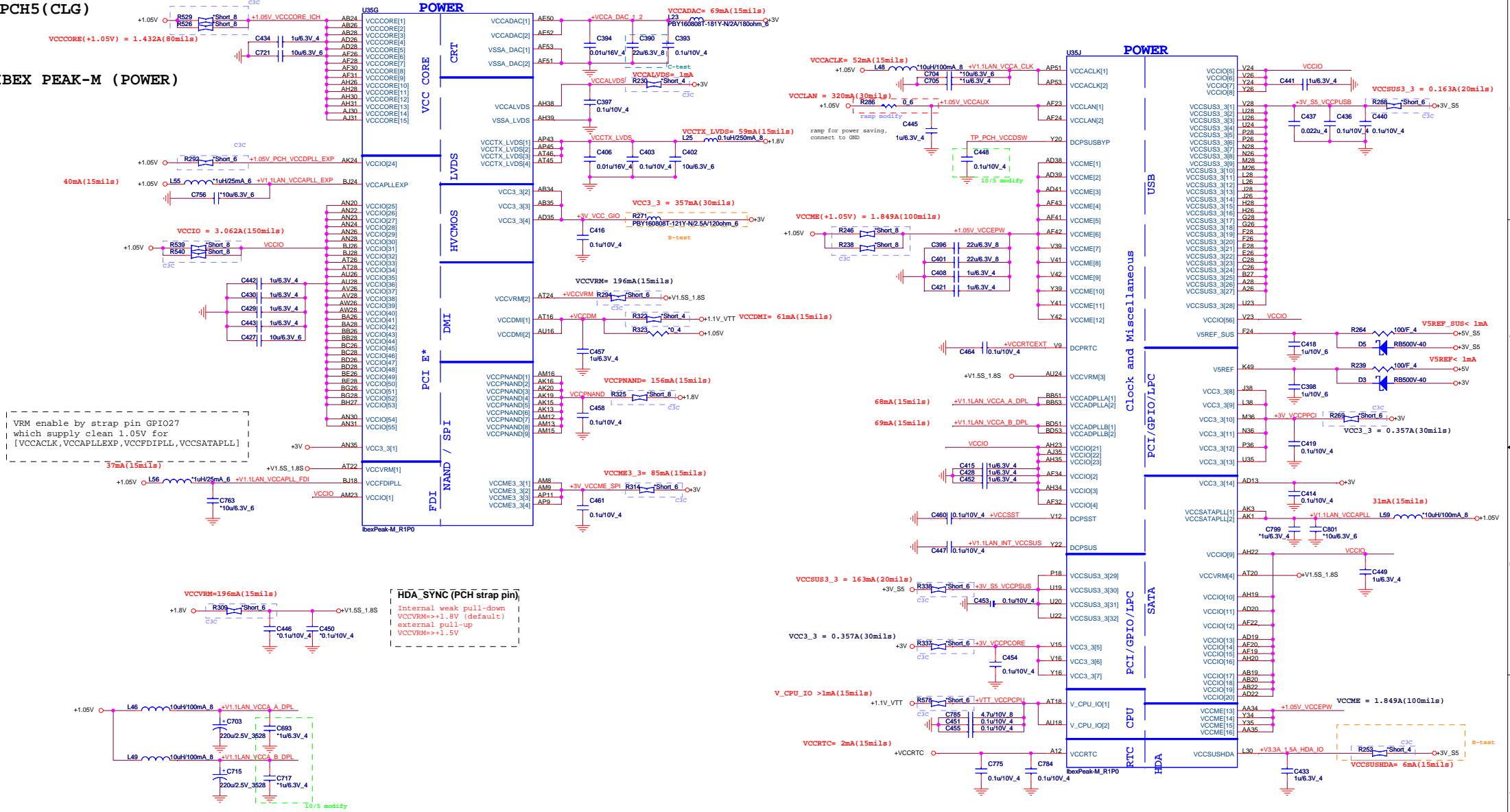

VRM enable by strap pin GPIO27 which supply clean 1.05V for [VCCACLK, VCCAPLLEX, VCCPDIFLL, VCCSATAPLL]

HDA_SYNC (PCH strap pin)
Internal weak pull-down
VCCVRM=>1.5V (default)
external pull-up
VCCVRM=>1.5V

IBEX PEAK-M (GND)

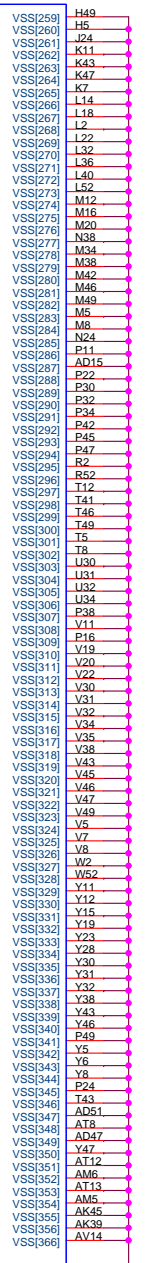
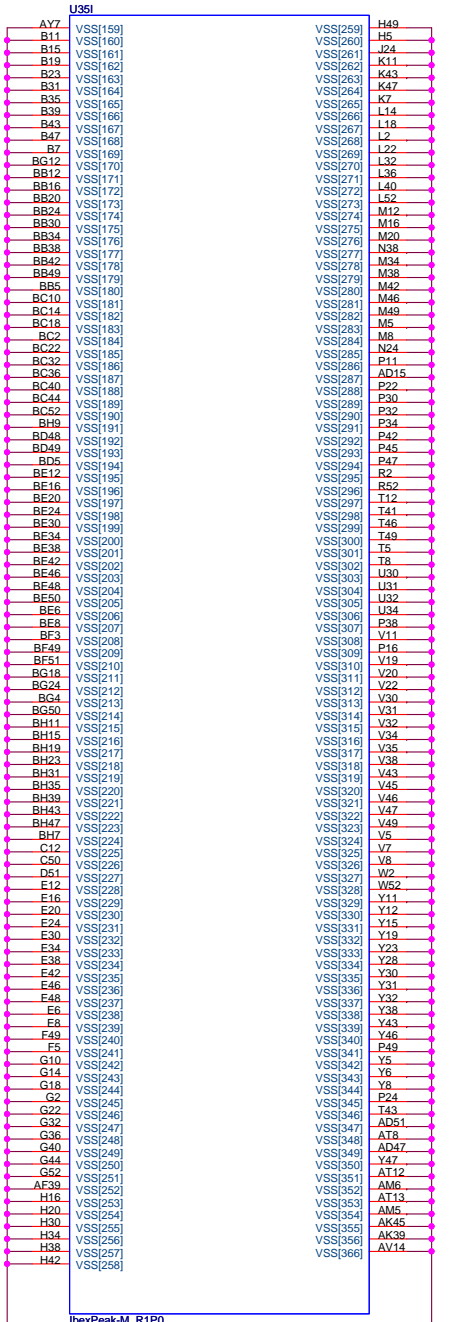
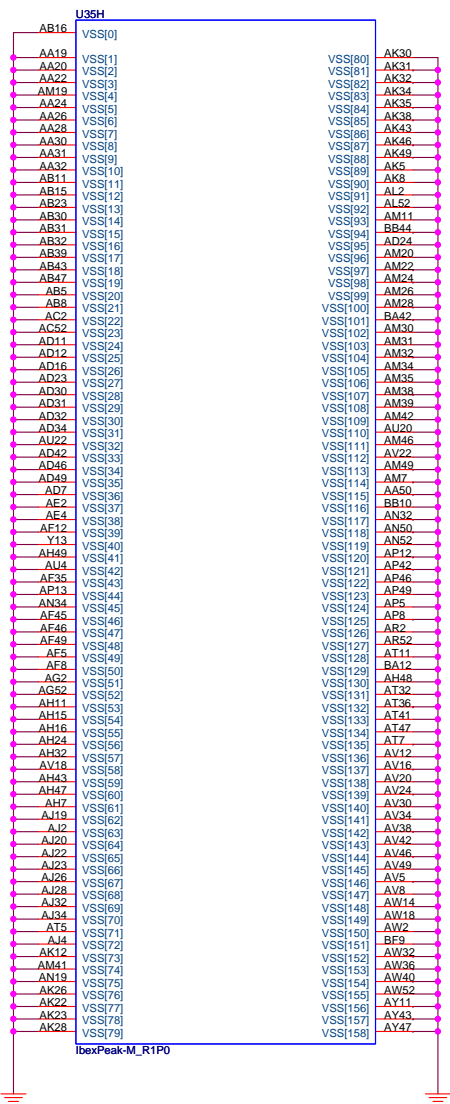

Quanta Computer Inc.
PROJECT : ZQ1

Size	Document Number	Rev
	IBEX PEAK-M 6/6	1A
Date:	Wednesday, December 16, 2009	Sheet 13 of 48

DDR_STD (DDR)

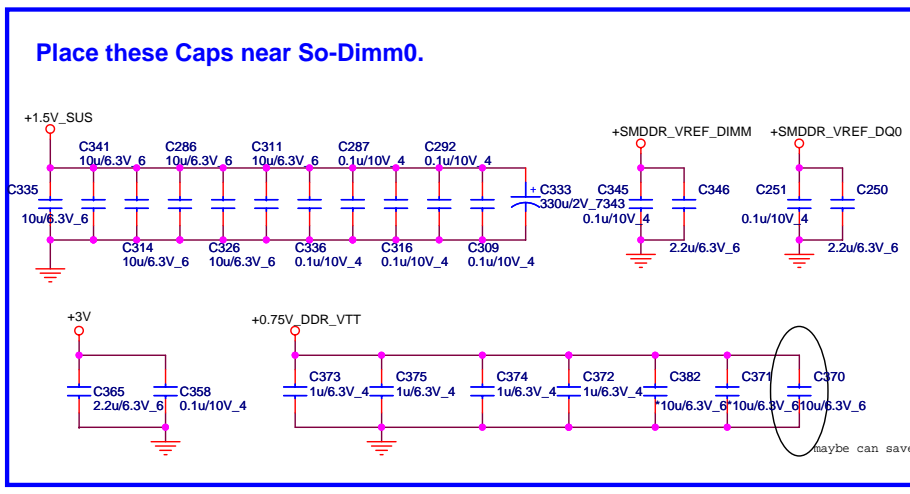
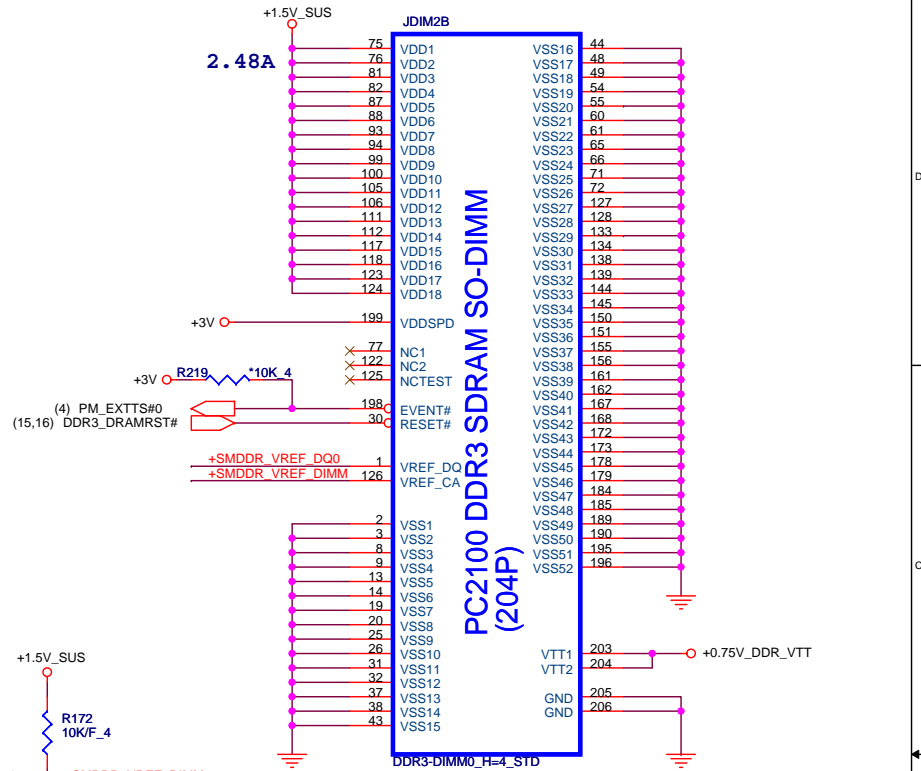
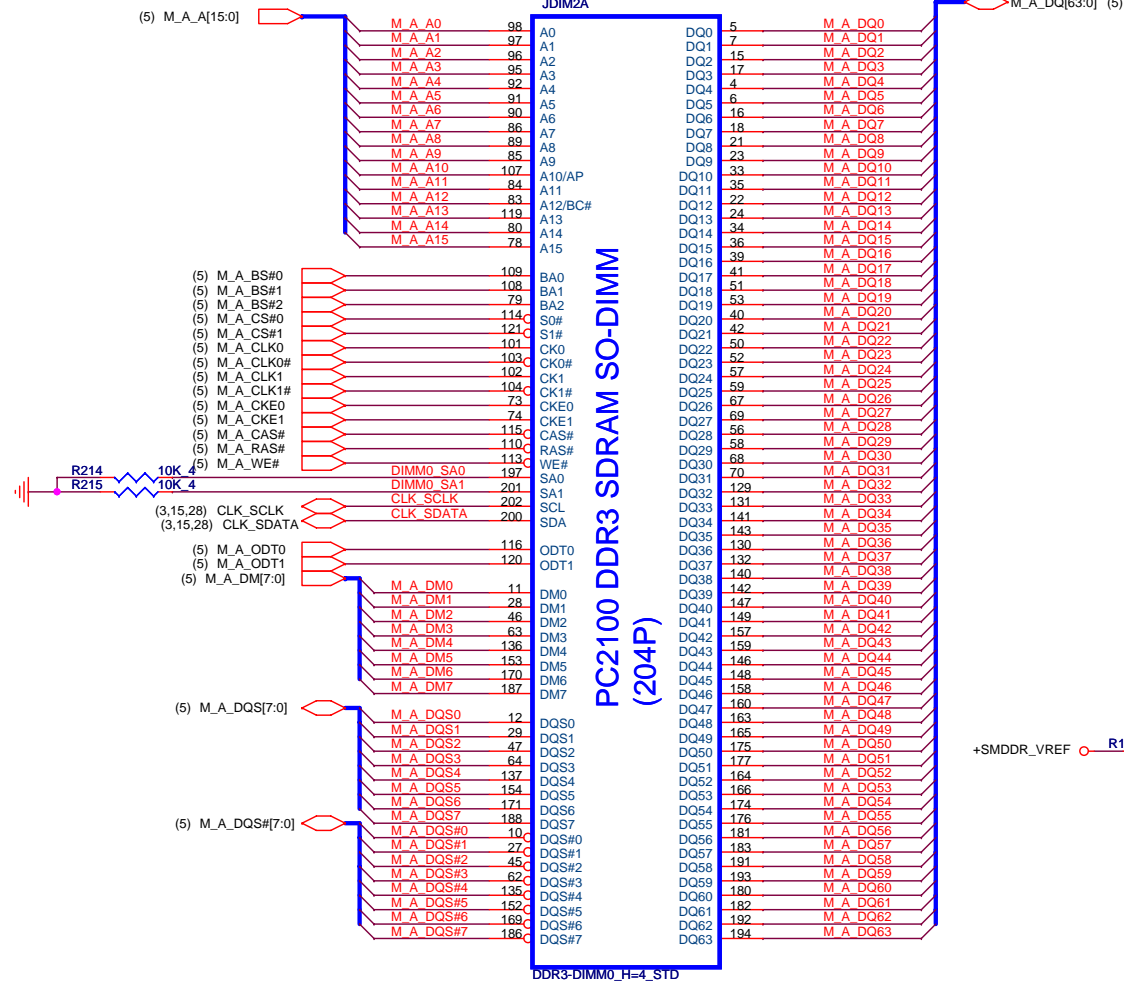

	STD 4H	STD 8H
FOX		
LTK	DGMK4000004	DGMK4000097
SUY		
MLX	DGMK4000011	DGMK4000080
Standard 4H type:DDR-C-2013289-204p		

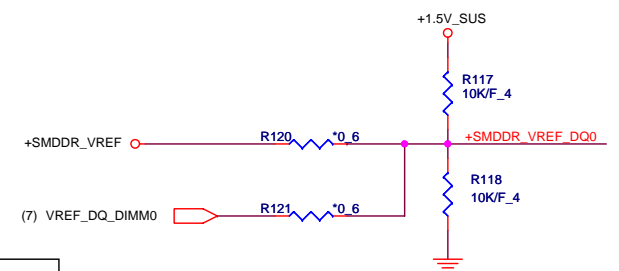

- M1:PWR SMDRR_VREF
- M1+:voltage divider(Default)
- M3:CPU VREF_DQ_DIMM0

Quanta Computer Inc.
PROJECT : ZQ1

Size	Document Number	Rev
	DDR3 SO-DIMM-0	1A
Date:	Friday, January 22, 2010	Sheet 14 of 48

DDR_STD (DDR)

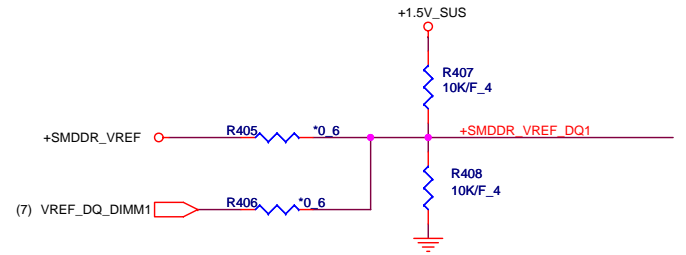
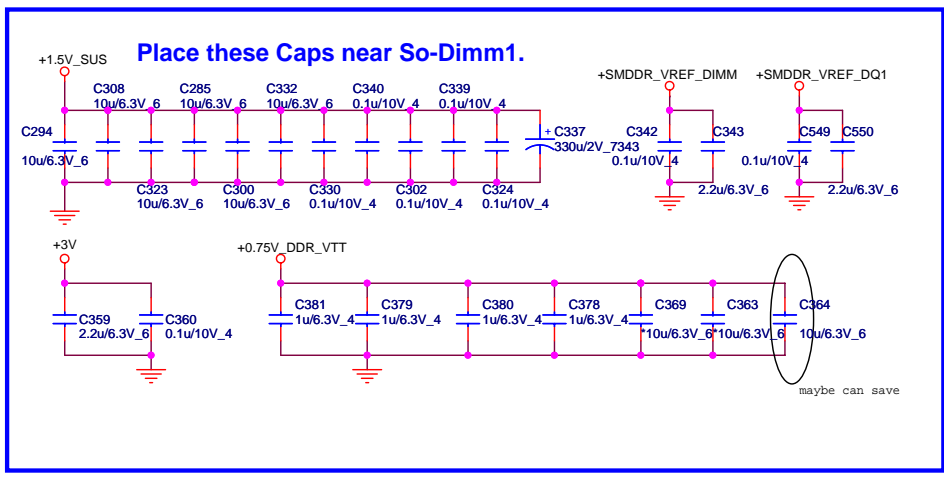
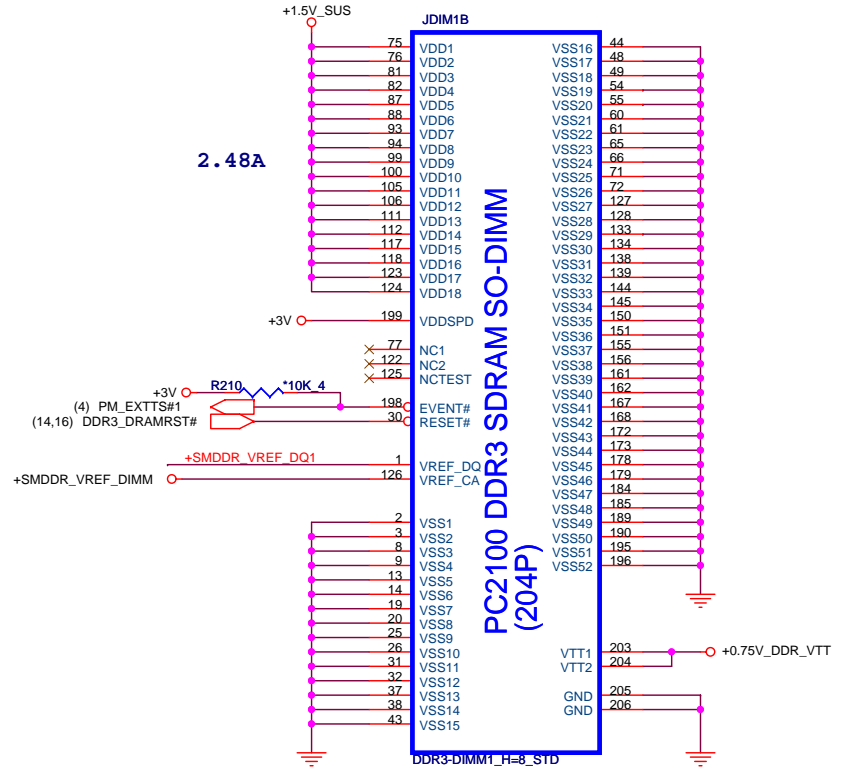
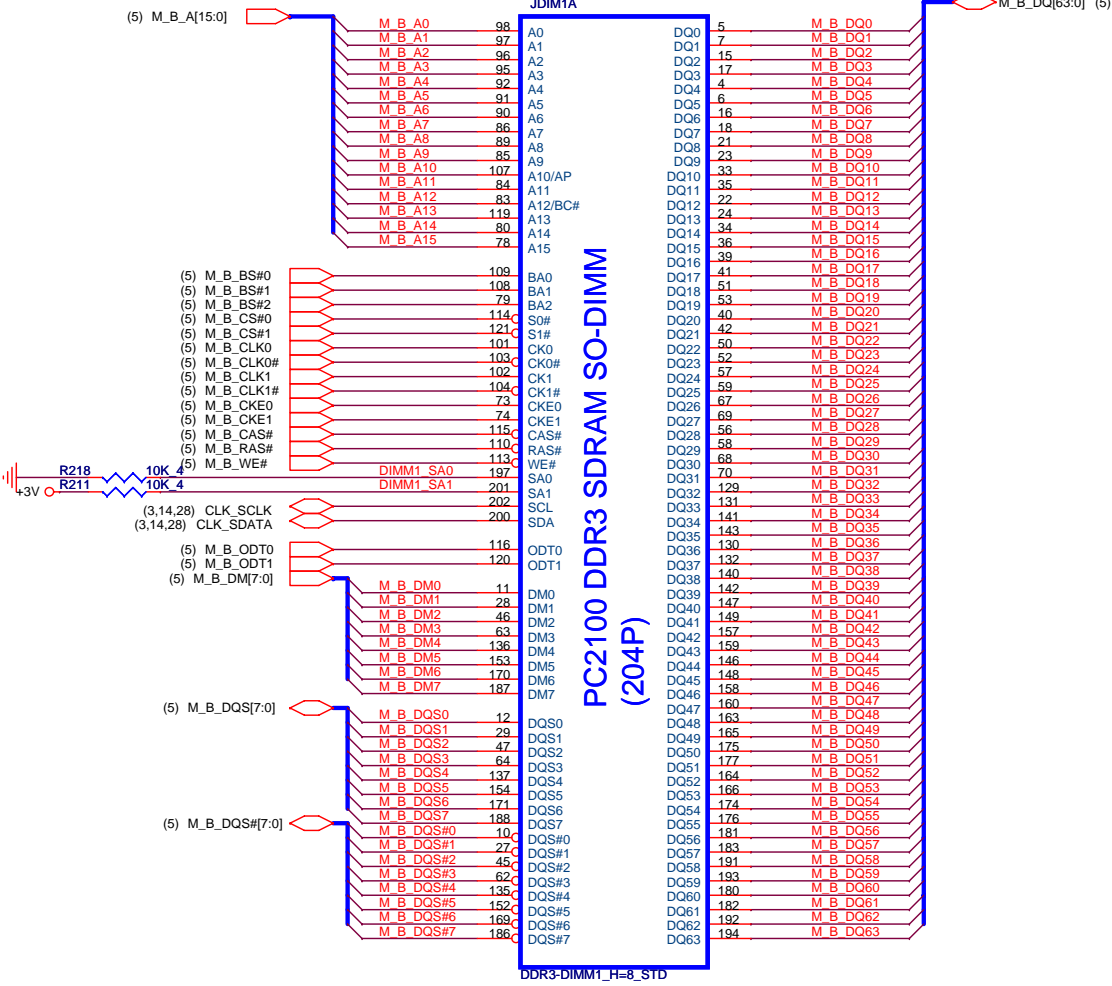

	STD 4H	STD 8H
FOX		
LTK	DGMK4000004	DGMK4000097
SUY		
MLX	DGMK4000011	DGMK4000080
Standard 8H type:DDR-C-2013310-204p-1		

- M1:PWR SMDDR_VREF
- M1+:voltage divider(Default)
- M3:CPU VREF_DQ_DIMM0

Quanta Computer Inc.
PROJECT : ZQ1

Size	Document Number	Rev
	DDR3 SO-DIMM-1	1A
Date:	Friday, January 22, 2010	Sheet 15 of 48

CPU XDP Connector(CPU)

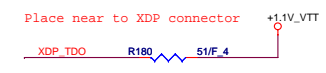
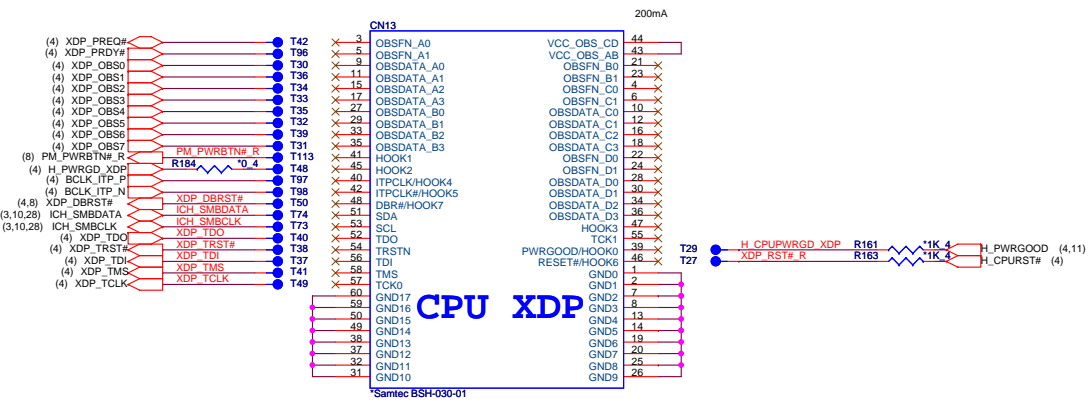

S3 leakage solution(CLG)

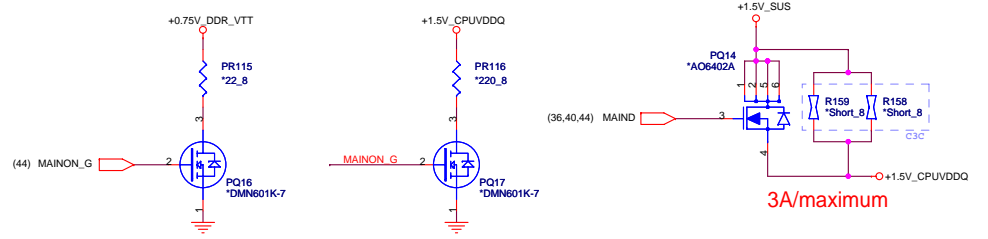
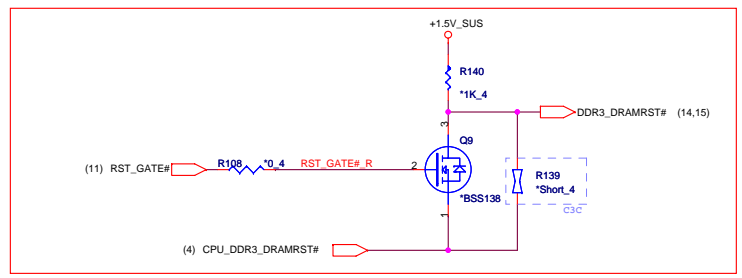
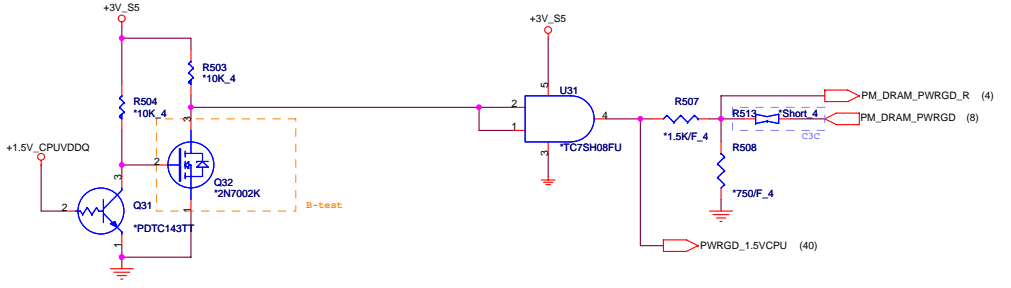

GPU_1(VGA)

U23A

0518 SWAP PCIE for VGA side

0518 SWAP PCIE for VGA side

PCI EXPRESS INFERPAGE

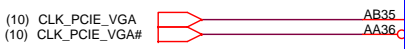
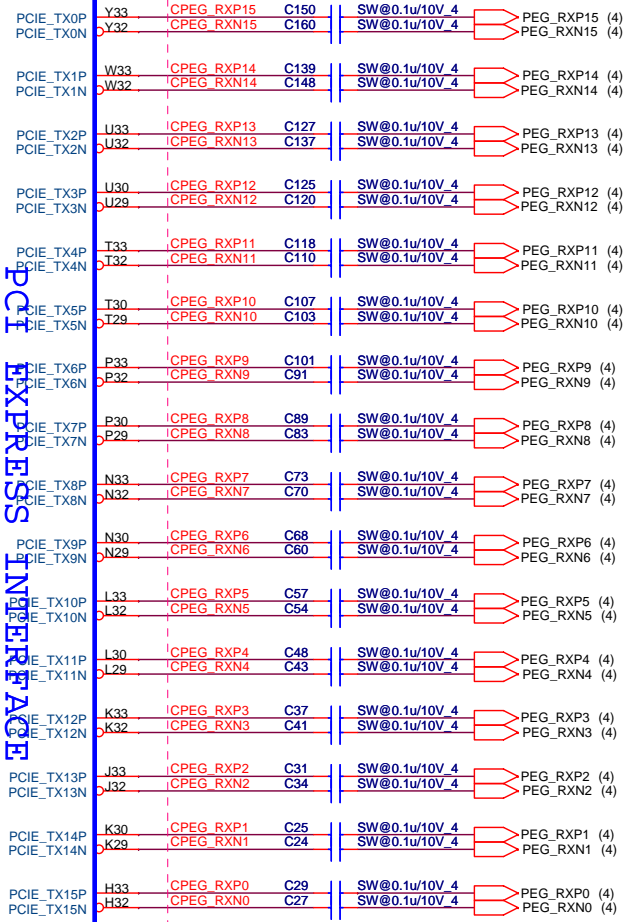
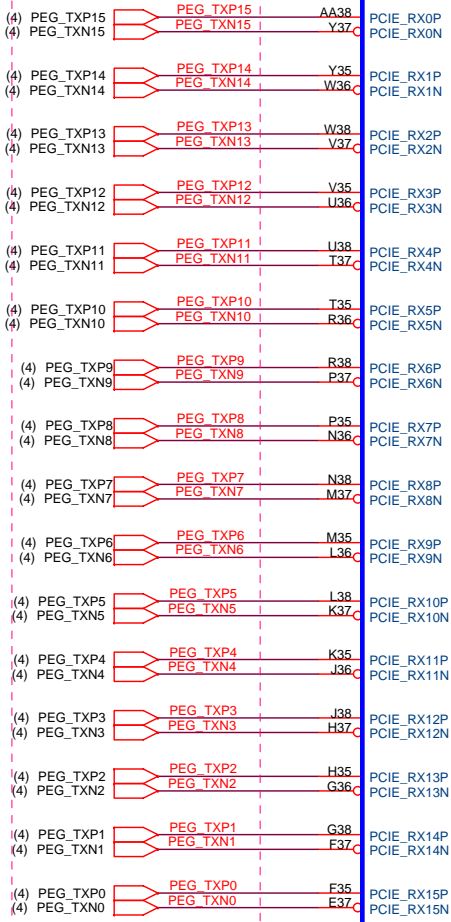
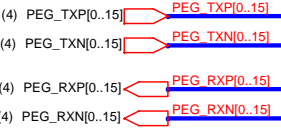

For Broadway, Madison and Park the PWRGOOD ball must be connected to ground

▲J21
▲K21
▲H16
R61 → SW@10K_4



SW@Madison/Park_M2

CALIBRATION



+1.0V

For M97, Broadway, Madison and Park PCIE_VDDC is 1.0V

Madison	AJ007720T02
Park	AJ077400T08

Quanta Computer Inc.
 PROJECT : ZQ1

Size	Document Number	Rev
	Madison/Park M2-PCIE I/F	1A
Date:	Friday, January 22, 2010	Sheet 17 of 48

GPU_2(VGA)

GPU Power-on sequence

- 1 => +VGPU_CORE
- 2 => +VGPU_IO
- 3 => +1V
- 4 => +1.5V_GPU
- 5 => +3V_D
- 6 => +1.8V_GPU
- 7 => dGPU_PWROK

1.8V GPIO

3.3V GPIO

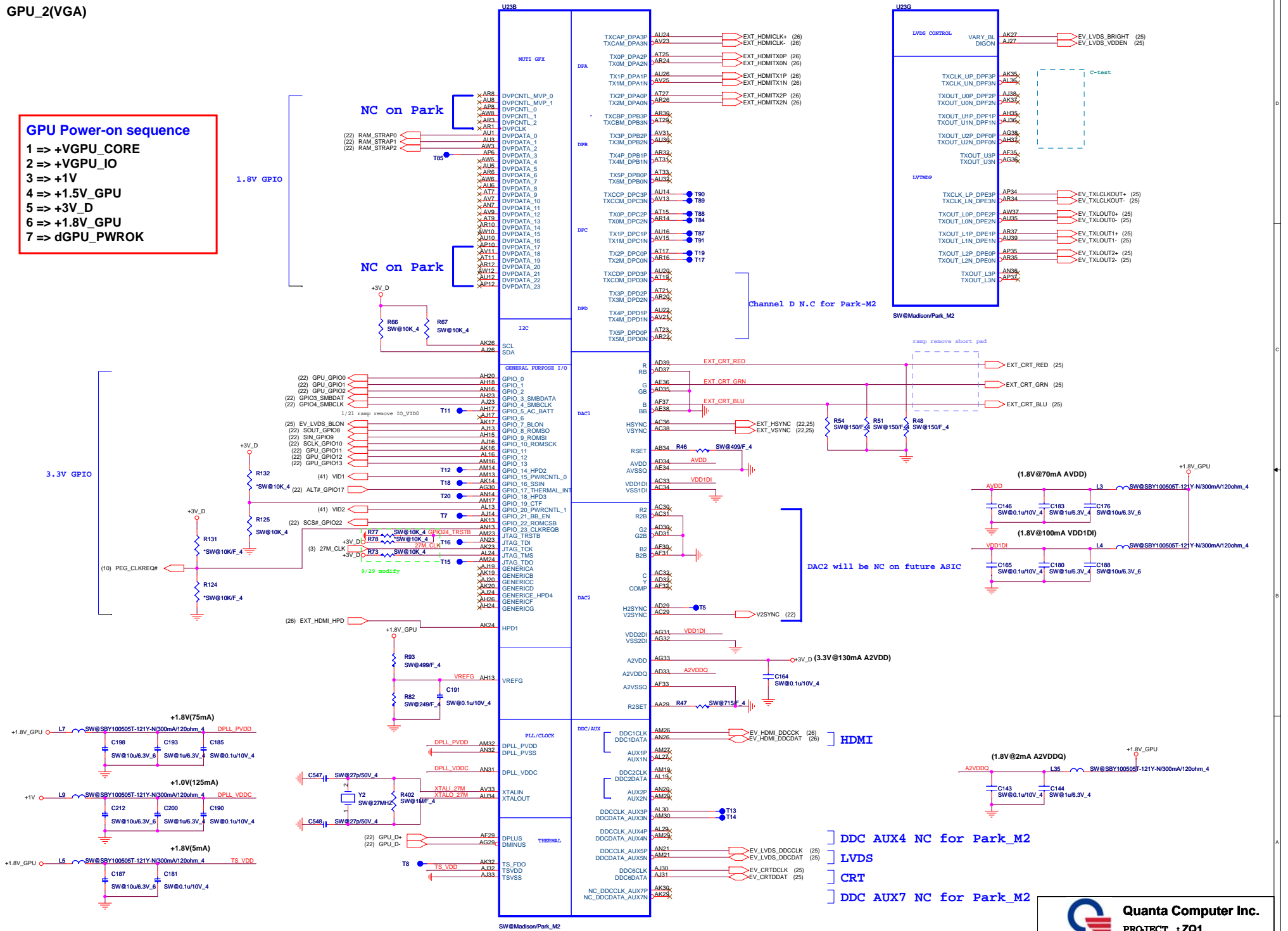

SW@MadisonPark_M2

HDMI

- DDC AUX4 NC for Park_M2
- LVDS
- CRT
- DDC AUX7 NC for Park_M2

Quanta Computer Inc.
PROJECT : ZQ1

Size	Document Number	Rev
	Madison/Park M2-HOST I/F	1A
Date:	Friday, January 22, 2010	Sheet 18 of 48

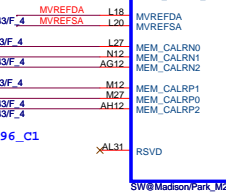
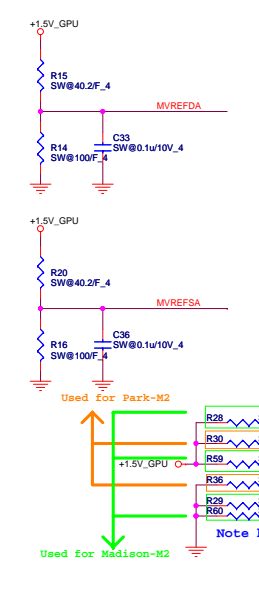
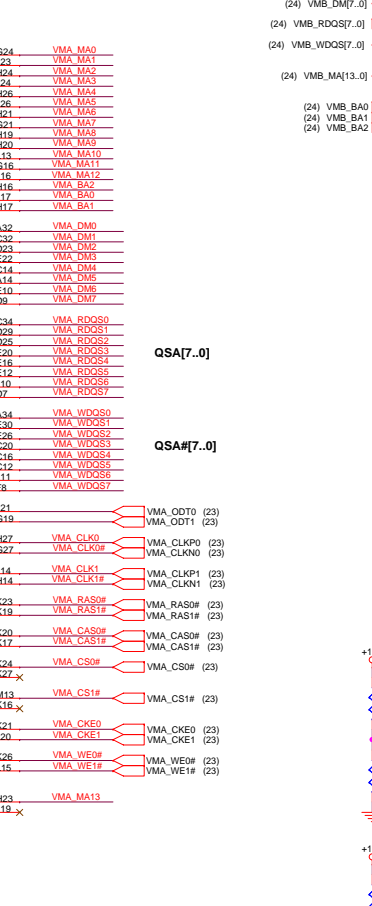
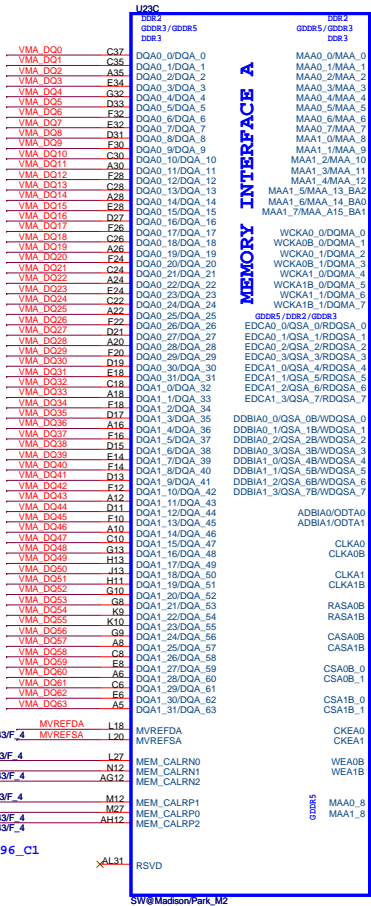
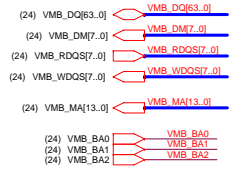
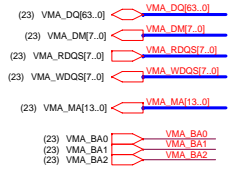

QSA[7..0]
QSA#[7..0]

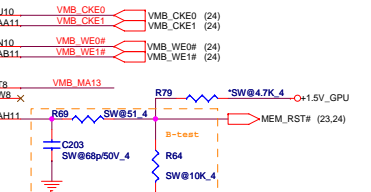
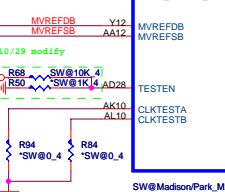
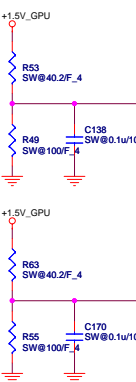
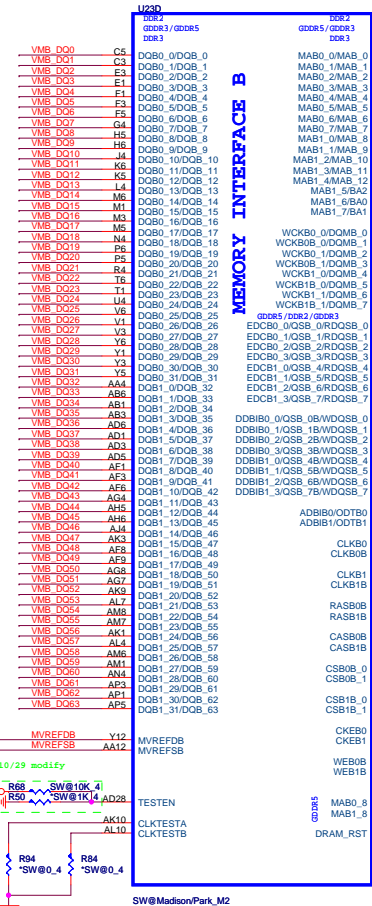

For DDR3, MVDDQ = 1.5V (7.5A)

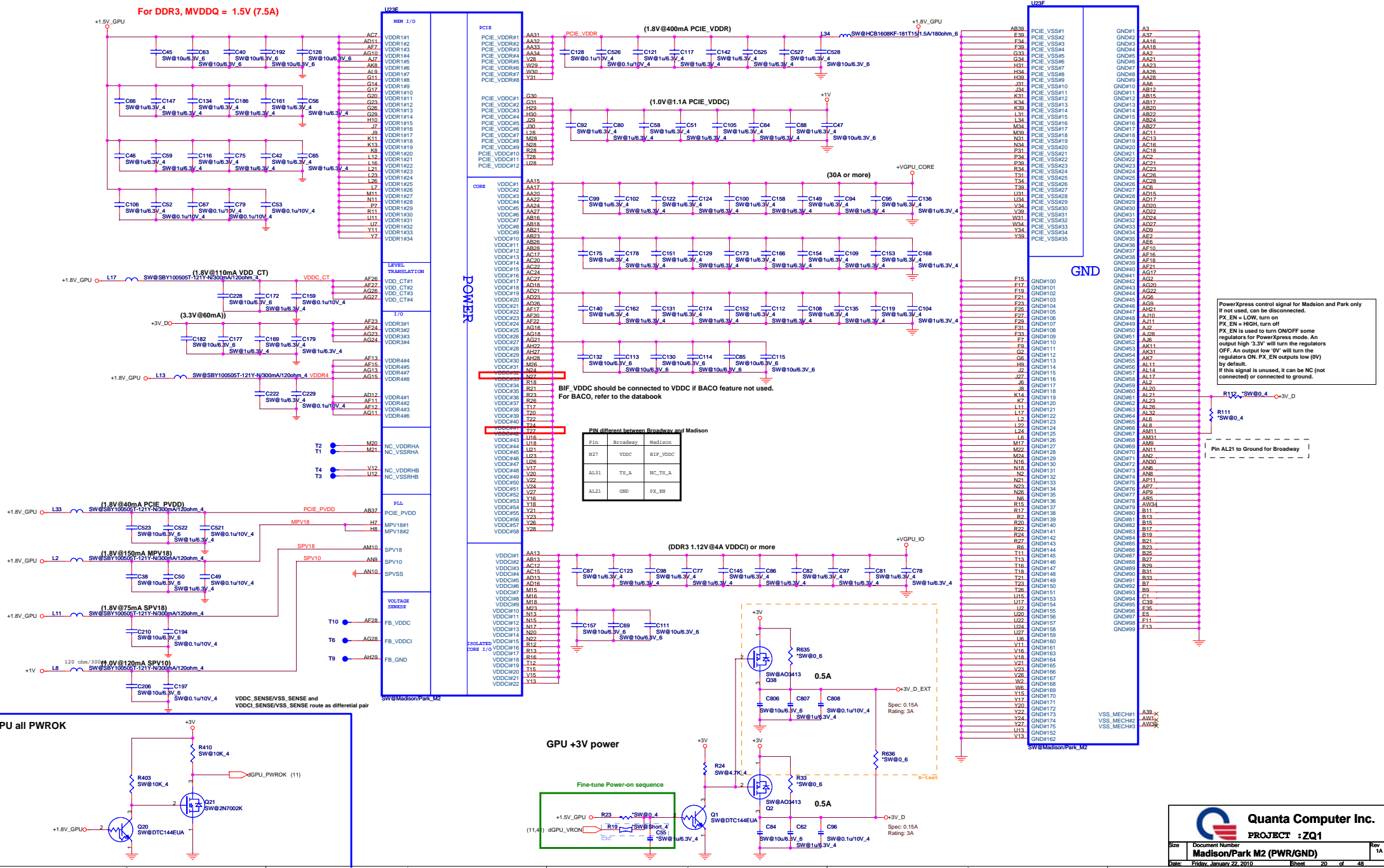

Pin different between Broadway and Madison

Pin	Broadway	Madison
N27	VDDC	BIF_VDDC
AL31	TS_A	NC_TS_A
AL21	GND	PX_EN

PowerPress control signal for Madison and Park only
 If not used, can be disconnected.
 PX_EN = LOW, turn on
 PX_EN = HIGH, turn off
 PX_EN is used to turn ON/OFF some regulators for PowerPress mode. An output high 3.3V will turn the regulators OFF. An output low 0V will turn the regulators ON. PX_EN outputs low (0V) by default.
 If this signal is unused, it can be NC (not connected) or connected to ground.

Quanta Computer Inc.
PROJECT : ZQ1
 Size: Document Number: **MadisonPark M2 (PWR/GND)** Rev: 1A
 Date: Friday, January 22, 2010 Sheet: 20 of 48

GPU_5(VGA)

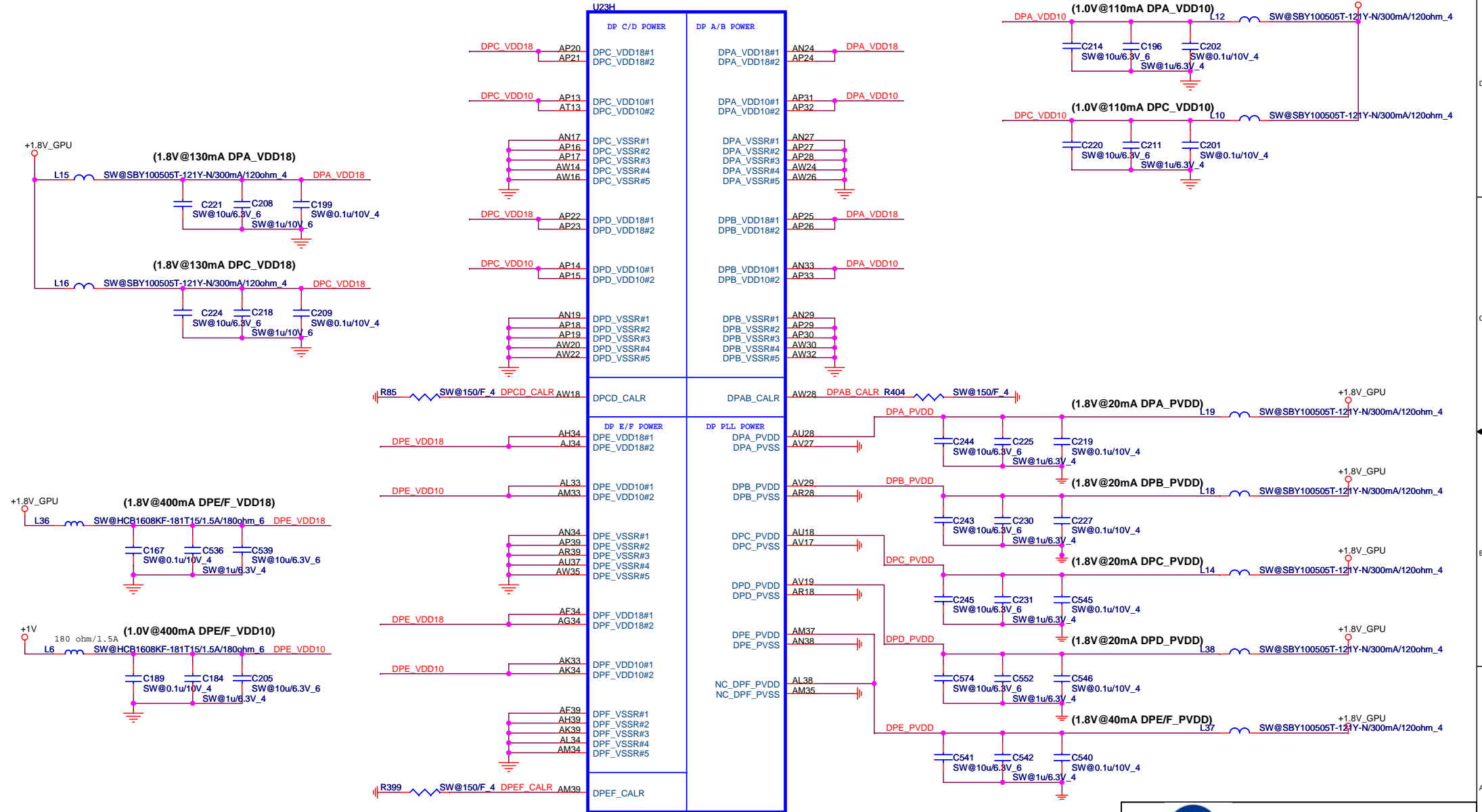



Quanta Computer Inc.
PROJECT : ZQ1

Size	Document Number	Rev
	Madison/Park M2 (DP_PWR/GND)	1A
Date:	Thursday, January 21, 2010	Sheet 21 of 48

PIN STRAPS(VGA)

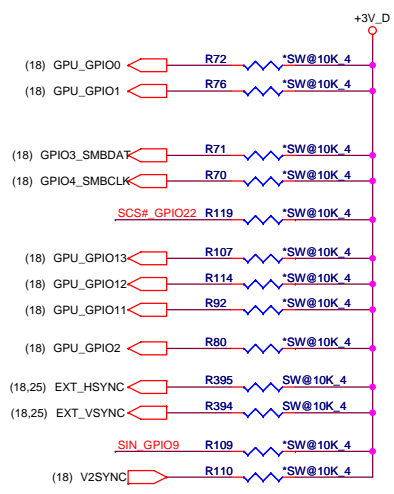

ROM Table		
Manufacturer	Part Number	Code
Numonyx ST Microelectronics	M25P05A	100
	M25P10A	101
	M25P20	101
	M25P40	101
	M25P80	101
Chingis PMC	Pm25LV512A	100
	Pm25LV010A	101

CONFIGURATION STRAPS				
ALLOW FOR PULLUP PADS FOR THESE STRAPS AND IF THESE GPIOs ARE USED, THEY MUST NOT CONFLICT DURING RESET				
STRAPS	PIN	DESCRIPTION OF DEFAULT SETTINGS	DEFAULT	REMARK
TX_PWRS_ENB	GPIO0	0 = 50% TX OUTPUT SWING 1 = FULL TX OUTPUT SWING	0	
TX_DEEMPH_EN	GPIO1	PCIE TRANSMITTER DE-EMPHASIS ENABLED 0 = TX DE-EMPHASIS DISABLED 1 = TX DE-EMPHASIS ENABLED	0	
BIOS_ROM_EN	GPIO_22_ROMCSB	ENABLE EXTERNAL BIOS ROM 0 = DISABLE 1 = ENABLE	1	
ROMIDCFG(2:0)	GPIOQ[13:11]	SERIAL ROM TYPE OR MEMORY APERTURE SIZE SELECT NUMONYX M25P10A : 101	101	See ROM table
BIF_GEN2_EN_A	GPIO2	0 = PCIE DEVICE AS 2.5GT/S CAPABLE 1 = PCIE DEVICE AS 5GT/S CAPABLE	0	
GPIO_8_ROMSO H2SYNC GPIO_21_BB_EN	GPIO8 H2SYNC GPIO21	Reserved Only	0	
AUD[1] AUD[0]	HSYNC VSYNC	AUD[1:0] 00: NO AUDIO FUNCTION. 01: AUDIO FOR DISPLAYPORT AND HDMI IF ADAPTER IS DETECTED. 10: AUDIO FOR DISPLAYPORT ONLY. 11: AUDIO FOR BOTH DISPLAYPORT AND HDMI.	11	See Audio table
GPIO_9_ROMSI	GPIO9	0 = VGA controller capacity enable	0	
VIP_DEVICE_STRAP_ENA	V2SYNC	0 = DRIVER would ignore the value sample on VHAD_0 during RESET.	0	

ROM Table		
EXT_HSYNC	EXT_VSYNC	Discription
0	0	No Audio
0	1	Any one by detectc
1	0	DP only
1	1	Both DP & HDMI

EEPROM(VGA)

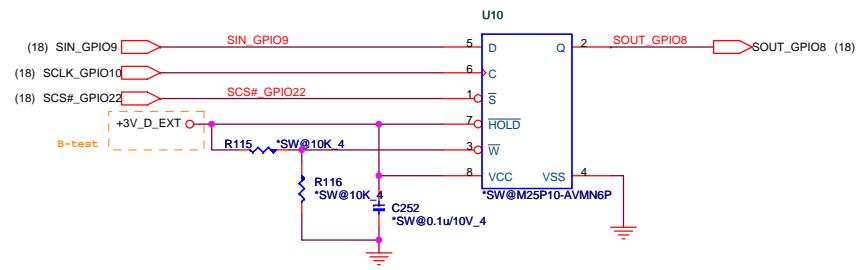

DDR3 Memory Aperture size(GPU)

DDR3 Memory Aperture size						
Vendor	Vendor P/N	STN B/S P/N	Size	RAM_STRAP2 DVPDATA_2	RAM_STRAP1 DVPDATA_1	RAM_STRAP0 DVPDATA_0
Hynix			512Mb	1	1	0
	H5TQ1G63BFR-12C	AKD5LZGTW04 (64M*16)	1Gb	1	0	0
			2Gb	1	0	1
Samsung			512Mb			
	K4W1G1646E-HC12	AKD5LGGT506 (64M*16)	1Gb	0	0	0
	K4W2G1646B-HC12	AKD5MGGT500	2Gb	0	0	1
AMD			512Mb			
	23EY2387MA12-SZ	AKD5LGGT700	1Gb	0	1	0

Thermal Sensor(VGA)

Vendor	P/N
WINDBOND	AL83L771K01
GMT	AL000780000

USD0.16

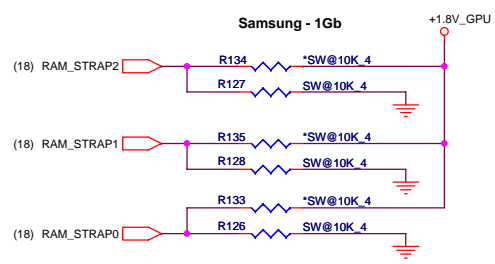
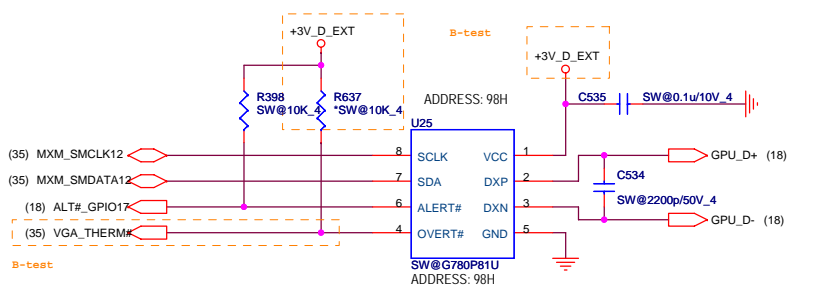

RAM_STRAP2 SET DDR3 Vendor
RAM_STRAP[1:0] SET SIZE.

Quanta Computer Inc.
PROJECT : ZQ1

Size Document Number Strip/Thermal Rev 1A
Date: Friday, January 22, 2010 Sheet 22 of 48

CHANNEL A: 512MB DDR3 (16*64M*4pcs)

Park, M92M Use Channel B Memory Interface Only

- (19) VMA_DQ[63..0] VMA_DQ[63..0]
 - (19) VMA_DM[7..0] VMA_DM[7..0]
 - (19) VMA_RDQS[7..0] VMA_RDQS[7..0]
 - (19) VMA_WDQS[7..0] VMA_WDQS[7..0]
- QSA[7..0] QSA[7..0]

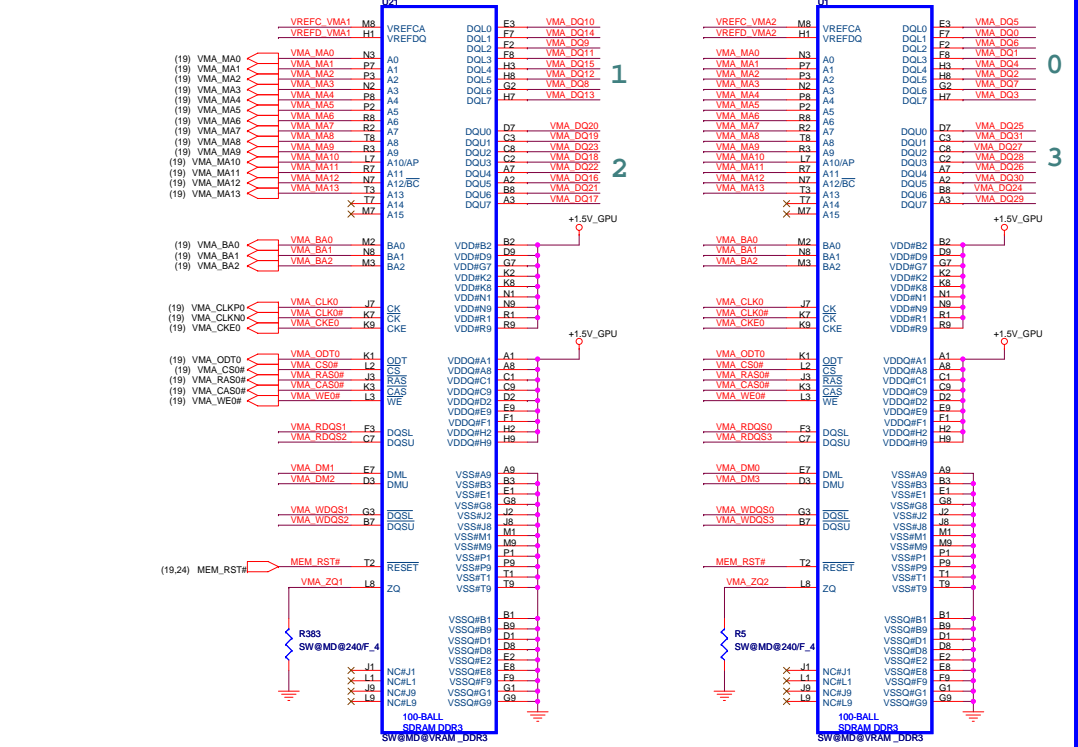

TOP Left

BOT Left

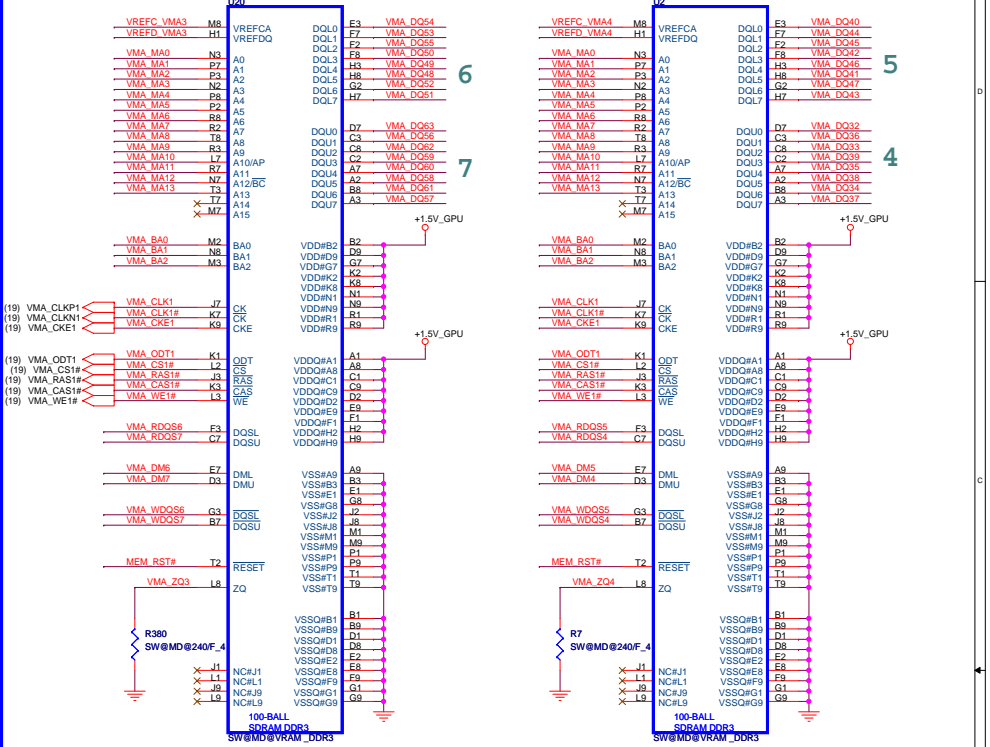

BOT Right

TOP Right

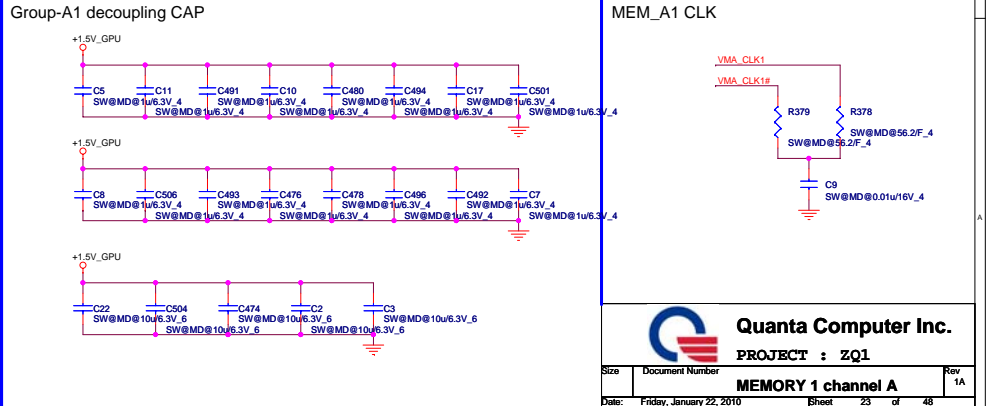
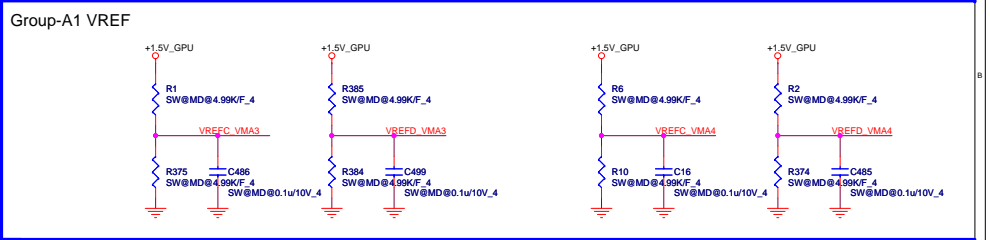
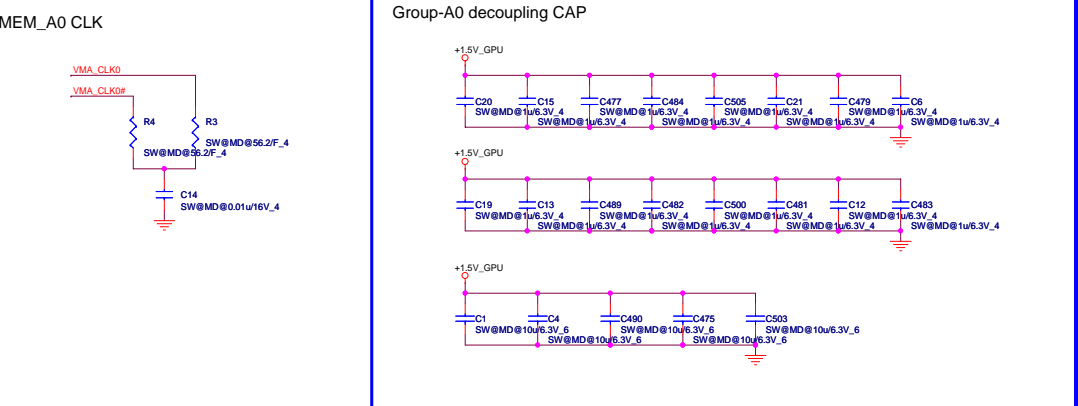
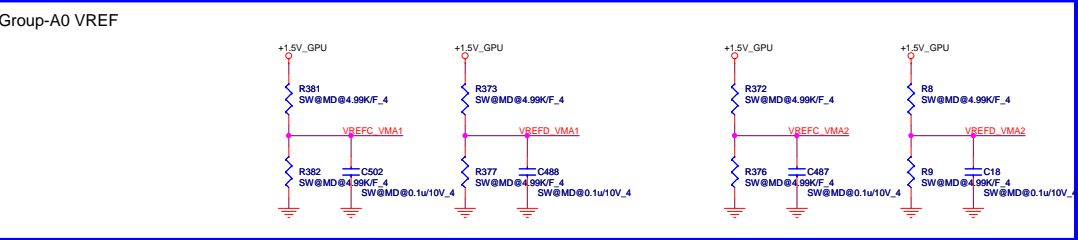

CHANNEL B: 512MB DDR3 (16*64M*4pcs)

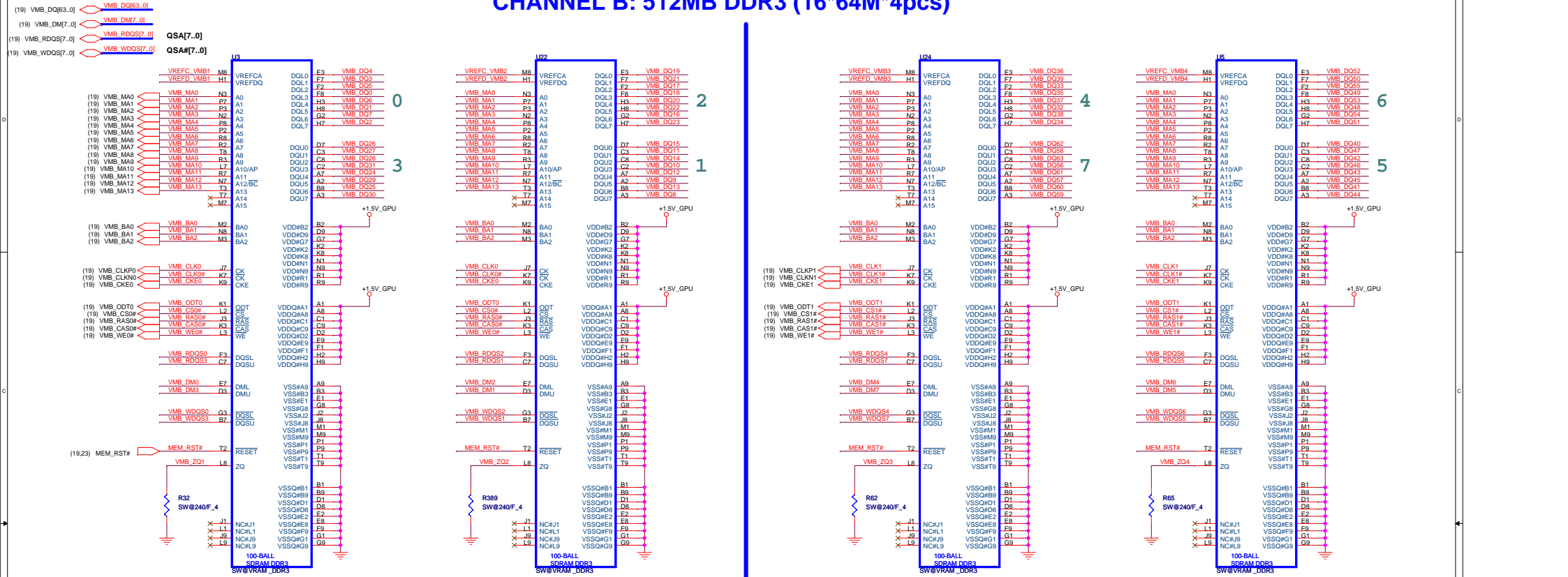

BOT Down

TOP Down

TOP Up

BOT Up

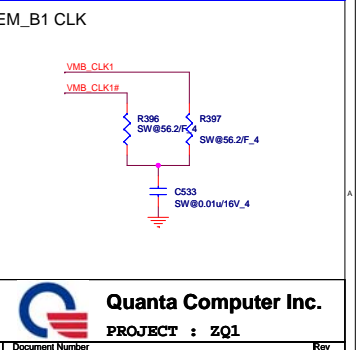
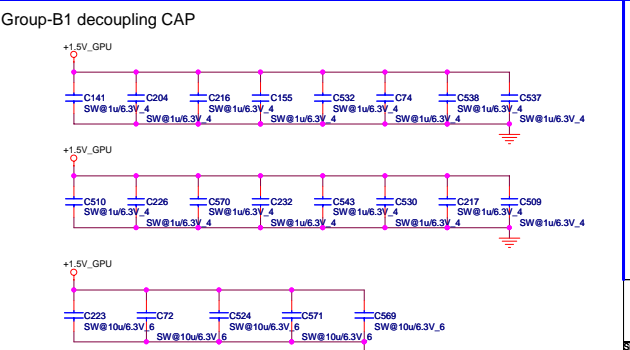
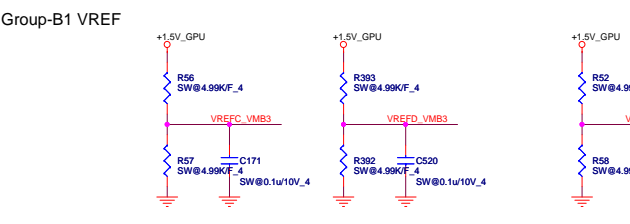
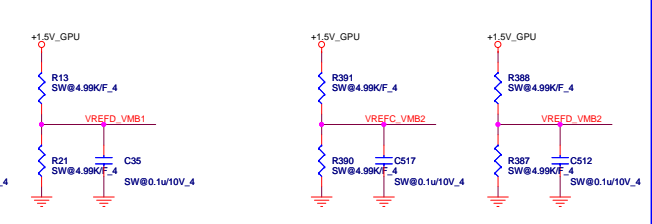
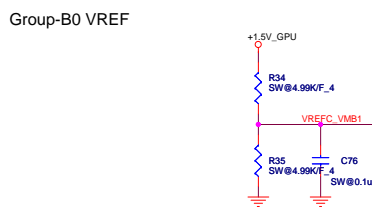

CRT(CRT)

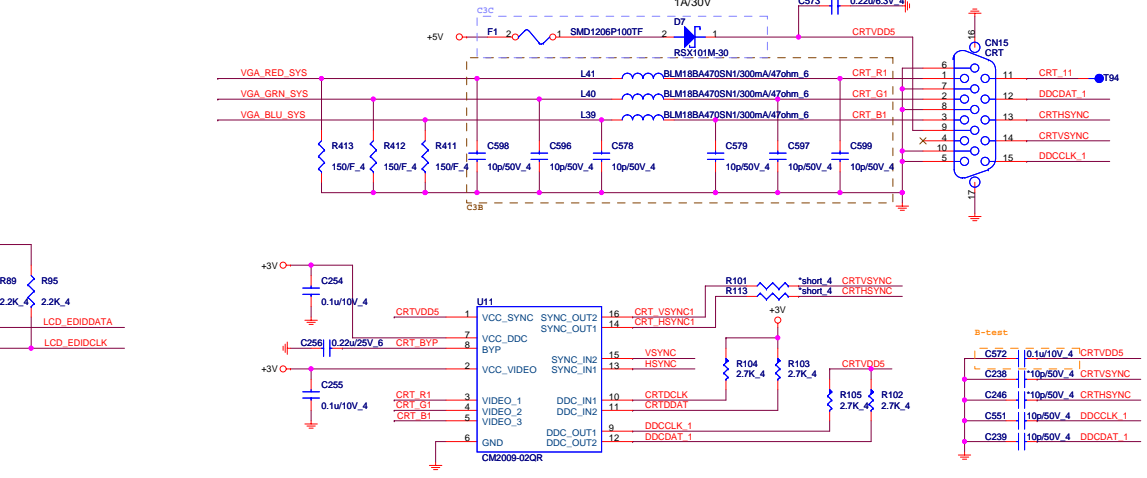
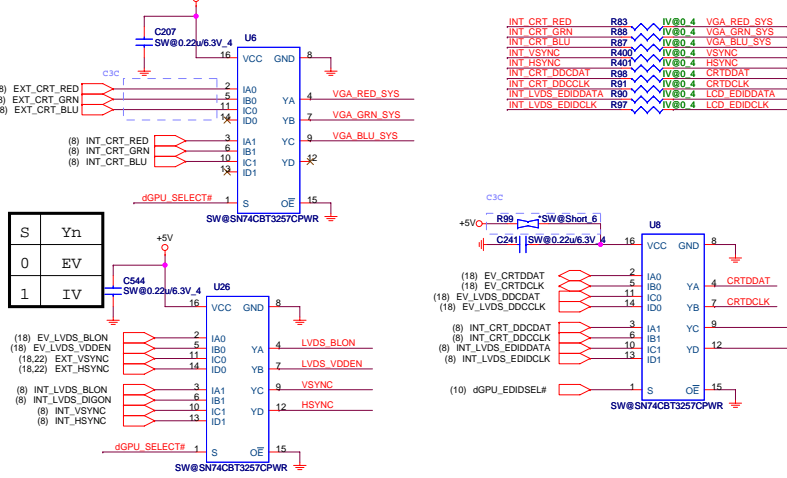

LVDS(LDS)

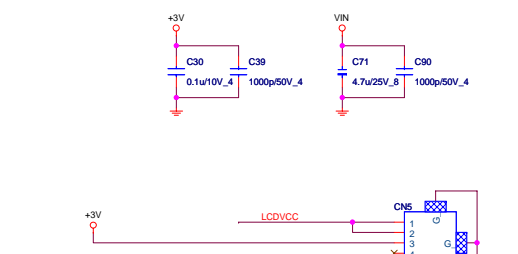
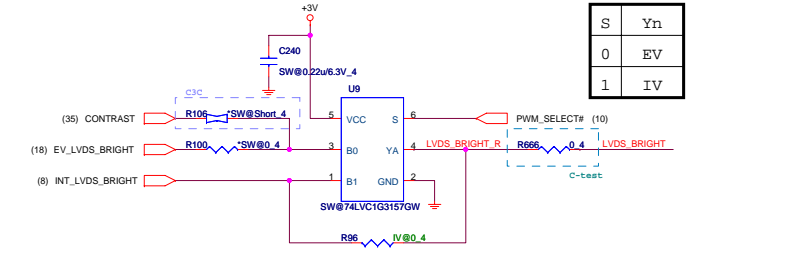

LCD Power(LDS)

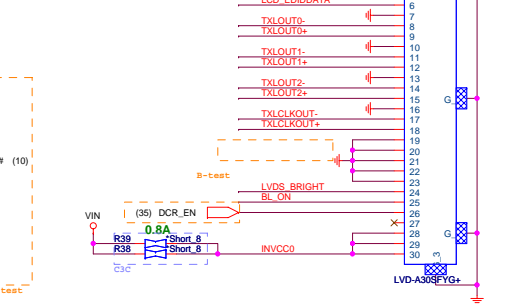
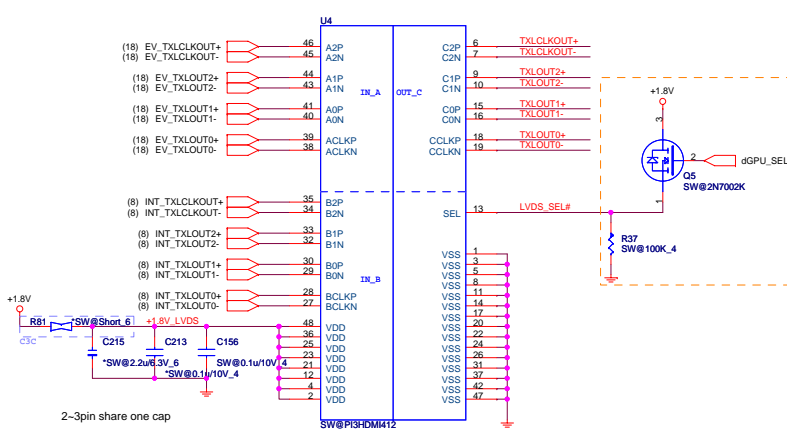
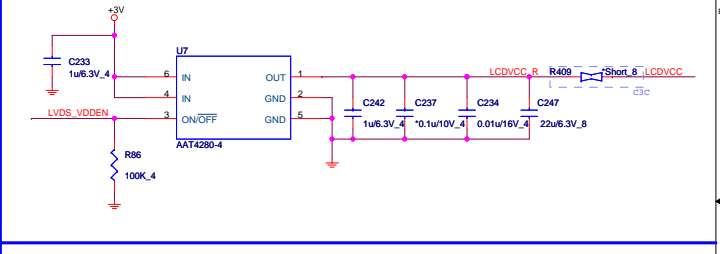

Backlight Control(LDS)

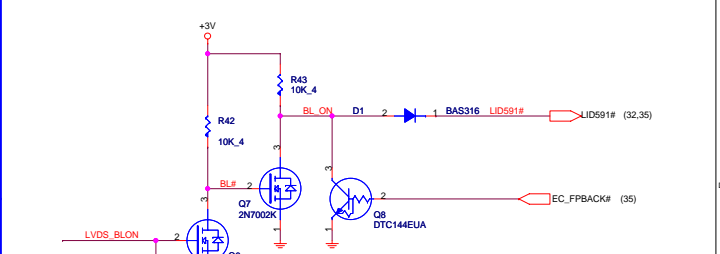

CCD&DMIC Conn.(CCD)

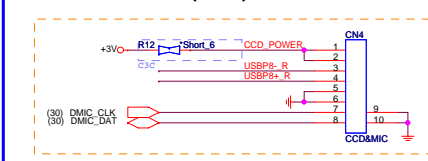

CAMERA Module(CCD)

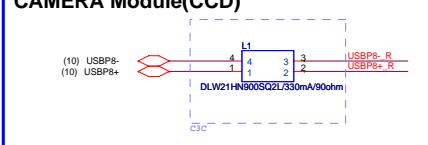

TI	AL3DV421V00
Pericom	AL000412W00

dGPU_SELECT#	Output
L	EV_LVDS
H	INT_LVDS

INT_LVDS_DIGON	RNS	1	2	IV@0.4P2R	LVDS_VDDEN
INT_LVDS_BLON	RNS	2	2	IV@0.4P2R	LVDS_BLON
INT_TXLCLKOUT+	RNT	3	4	IV@0.4P2R	TXLCLKOUT+
INT_TXLCLKOUT-	RNT	4	4	IV@0.4P2R	TXLCLKOUT-
INT_TXLOUT0+	RN3	4	4	IV@0.4P2R	TXLOUT0+
INT_TXLOUT0-	RN3	5	2	IV@0.4P2R	TXLOUT0-
INT_TXLOUT1+	RN3	6	4	IV@0.4P2R	TXLOUT1+
INT_TXLOUT1-	RN3	7	2	IV@0.4P2R	TXLOUT1-
INT_TXLOUT2+	RN2	4	4	IV@0.4P2R	TXLOUT2+
INT_TXLOUT2-	RN2	5	2	IV@0.4P2R	TXLOUT2-

HDMI HPD(HDM)

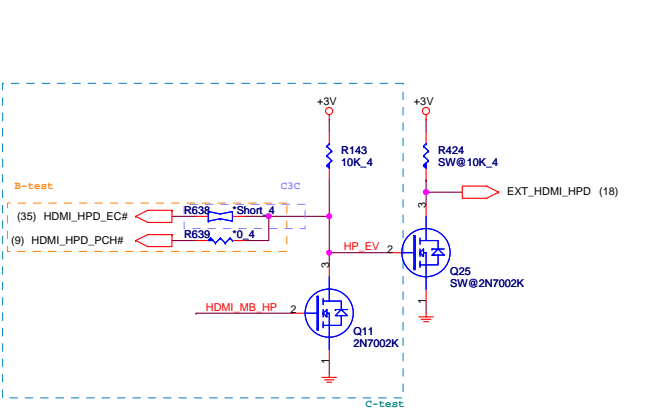

HDMI LEVEL SHIFTER(HDM)

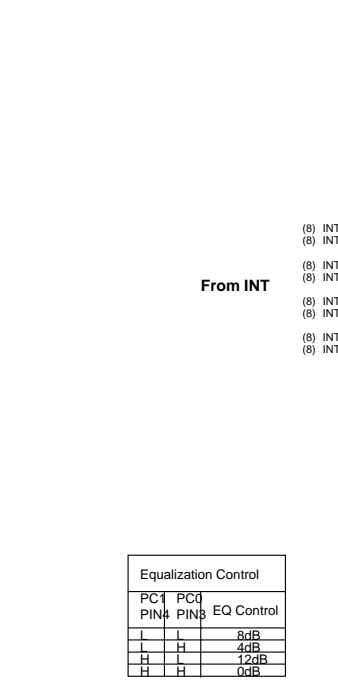

PS8101 :: AL008101000

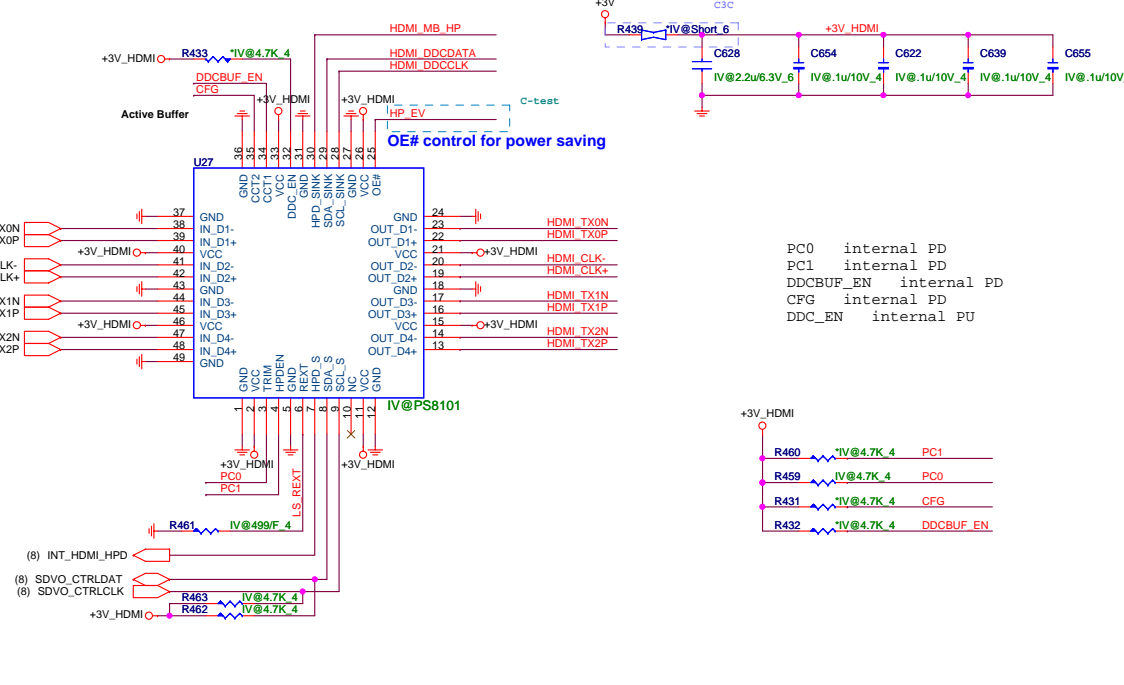

(HDM)

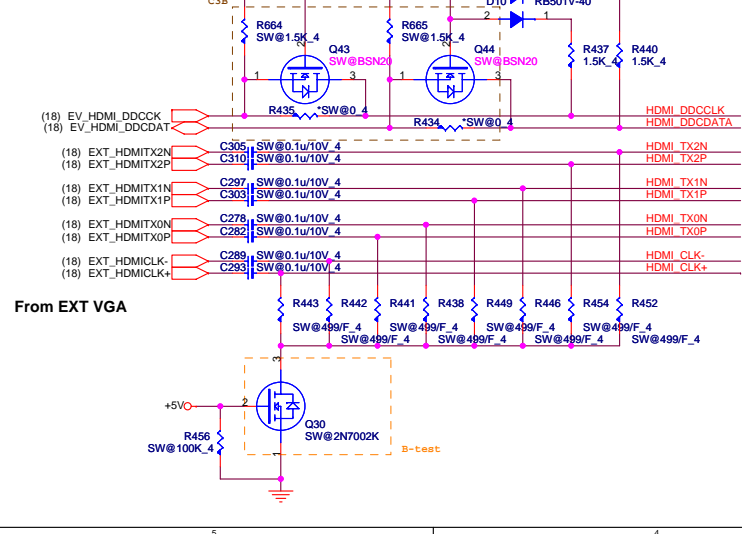

EMI reserve for HDMI(HDM)

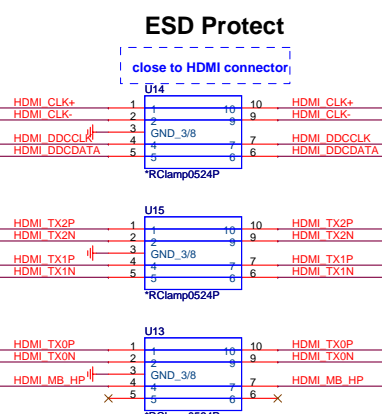
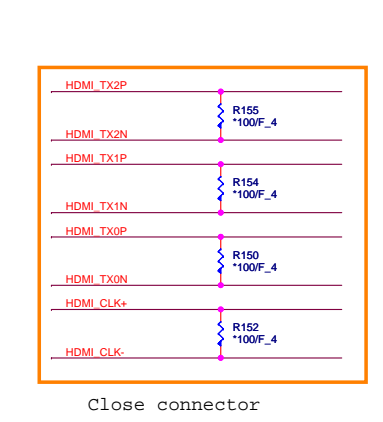

HDMI connector(HDM)

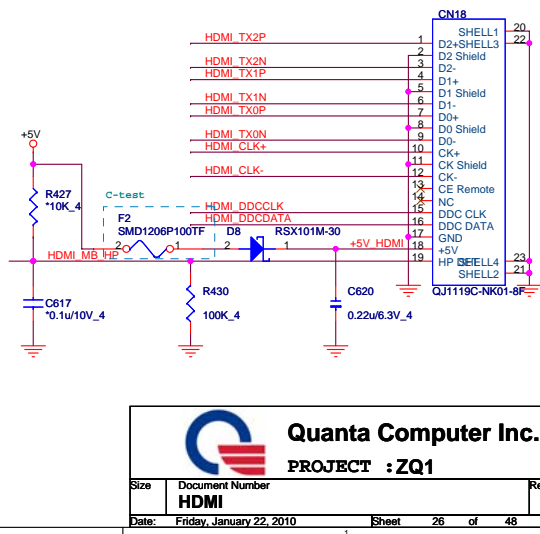

Quanta Computer Inc.
PROJECT : ZQ1

Size	Document Number	Rev
	HDMI	1A

Date: Friday, January 22, 2010 Sheet 26 of 48

Giga-LAN AR8151(LAN)

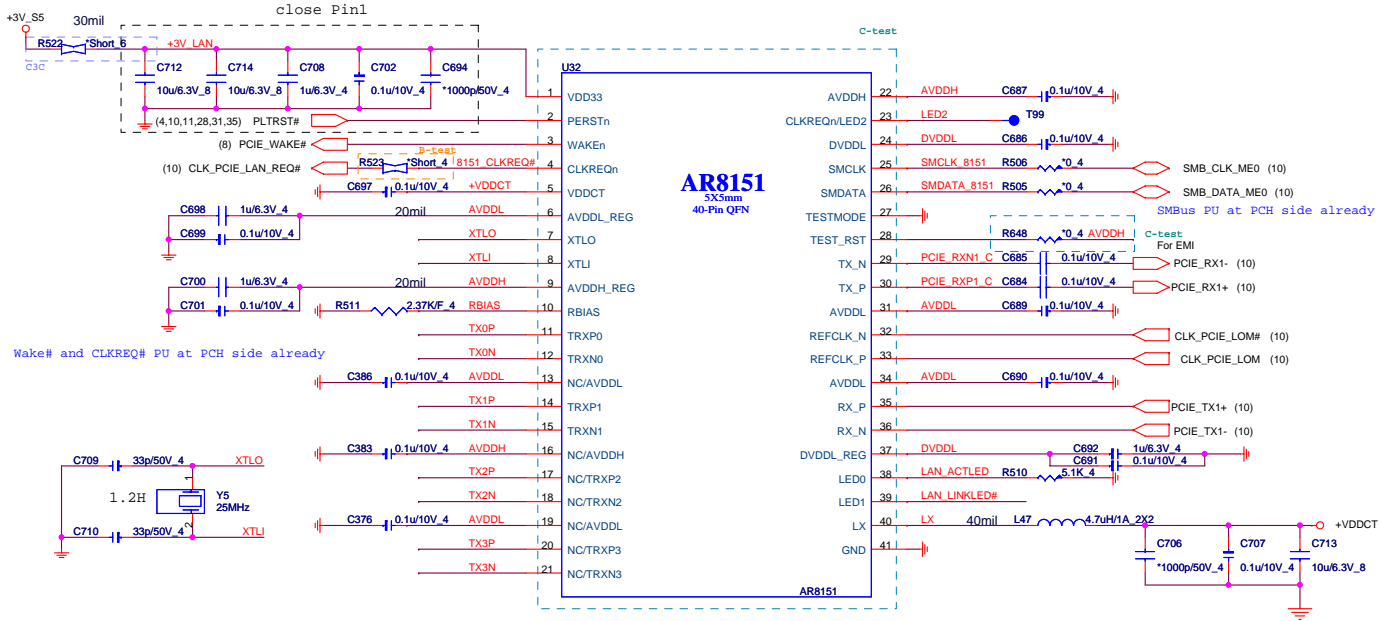

TRANSFORMER(LAN)

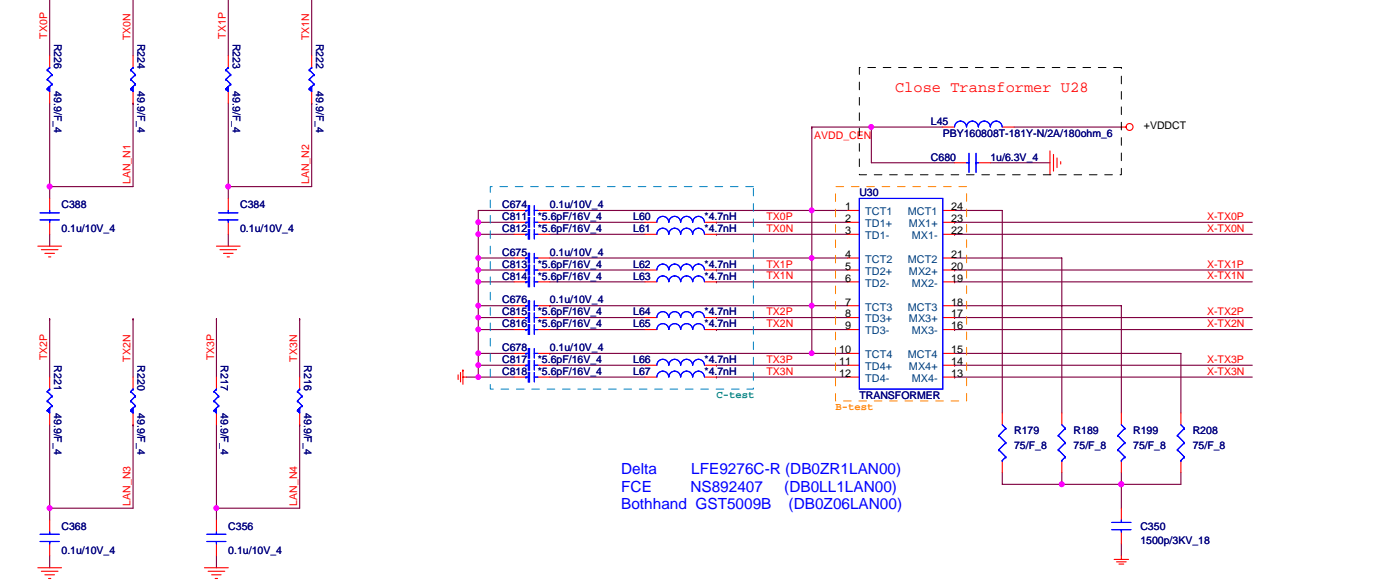

RJ45(LAN)

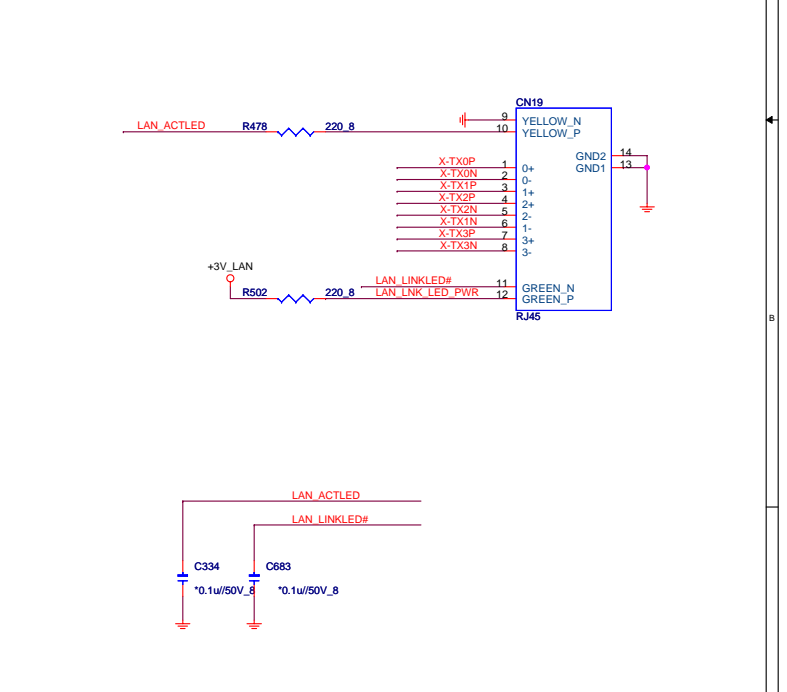

MINI-CARD WLAN(MPC)

+3.3V: 1000mA
 +3.3Vaux: 330mA
 +1.5V: 500mA

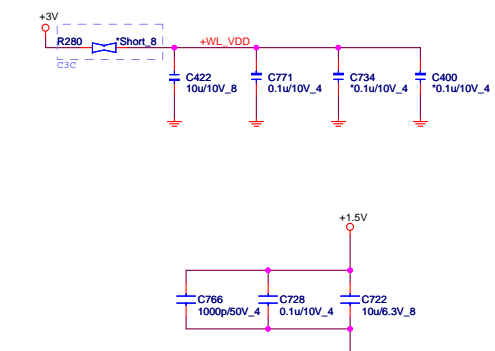
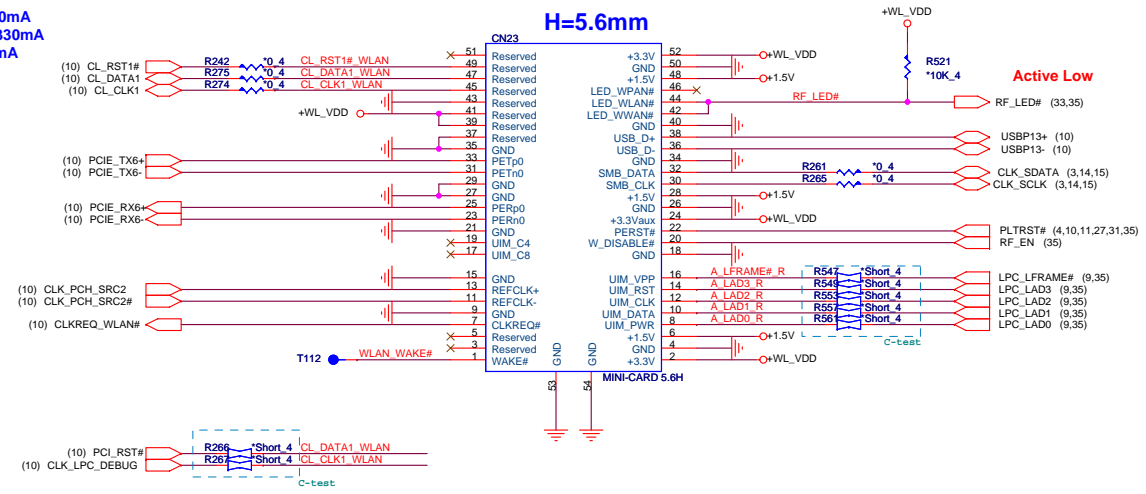

MINI-CARD 3G(MNC)Reserve for JV41-CP

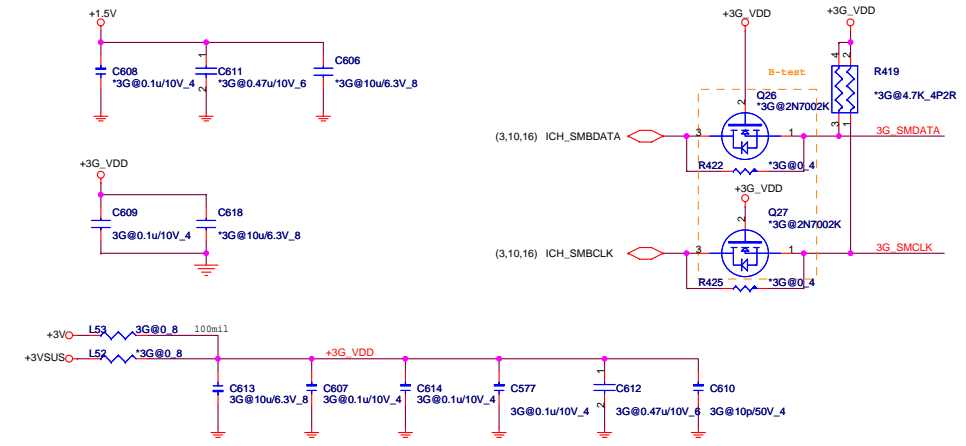
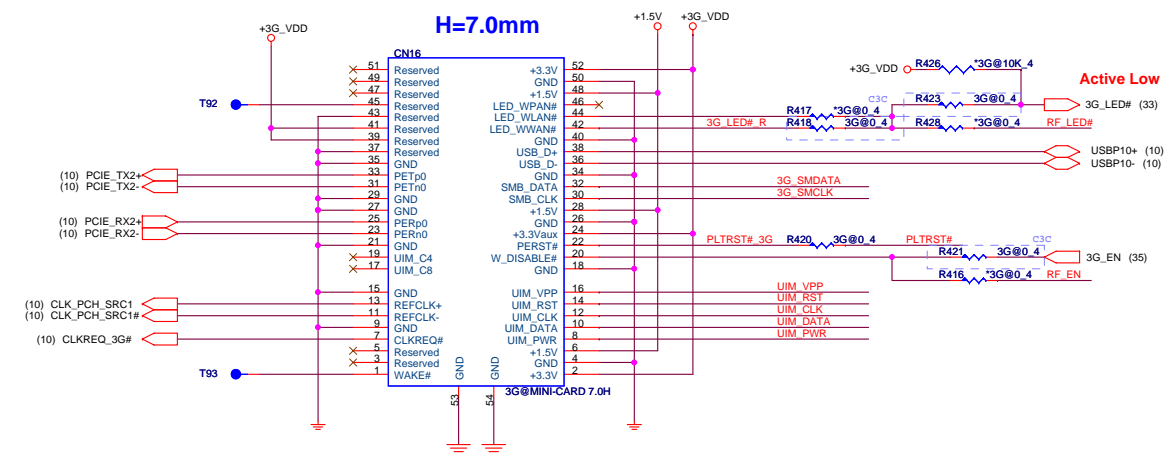

A: (10/17)FAE confirm:
 3G module need +3VSUS and no need +1.5V and no need SMBUS

SIM CARD FFC connector(RFM)

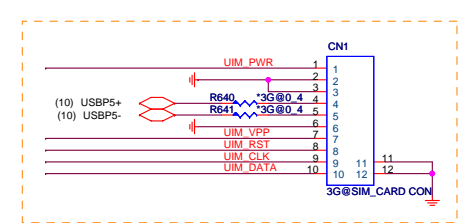

Quanta Computer Inc.
 PROJECT : ZQ1

Size	Document Number	Rev
	Mini-Card/WL/3G/SIM	1A
Date:	Friday, January 22, 2010	Sheet 28 of 48

SATA HDD(HDD)

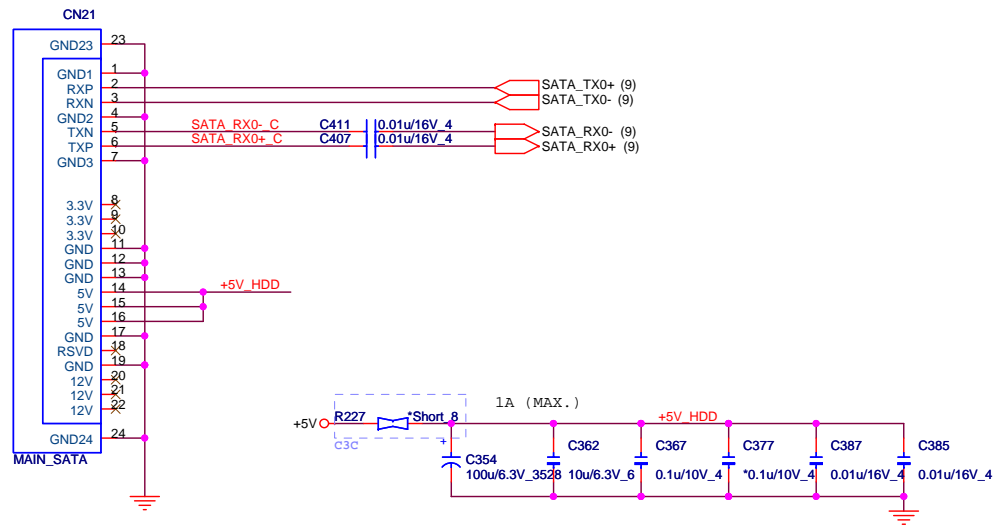

SATA ODD (ODD)

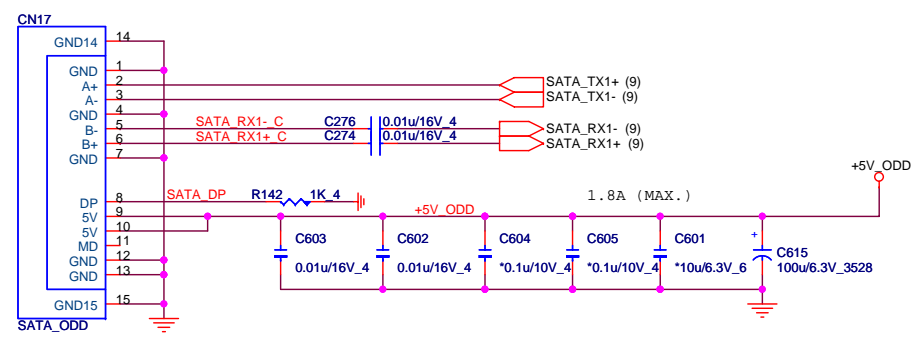

HOLE(OTH)

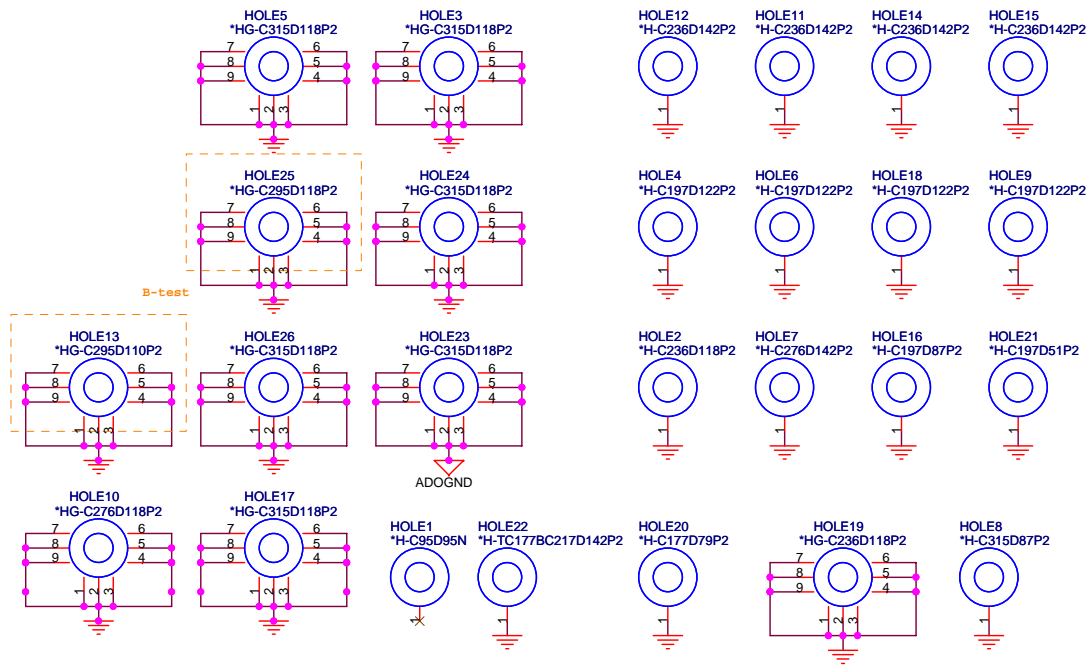

ODD POWER(ODD)

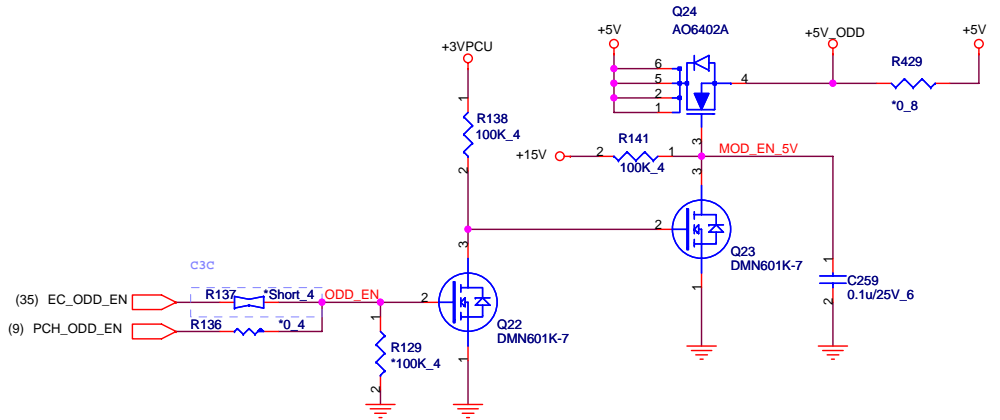

Connect to PCH(GPIO21) pin Y9 and EC pin28(GPIO53)

Quanta Computer Inc.
PROJECT : ZQ1

Size	Document Number	Rev
	SATA-HDD/ODD/HOLE	1A
Date: Friday, January 22, 2010		Sheet 29 of 48

Codec(ADO)

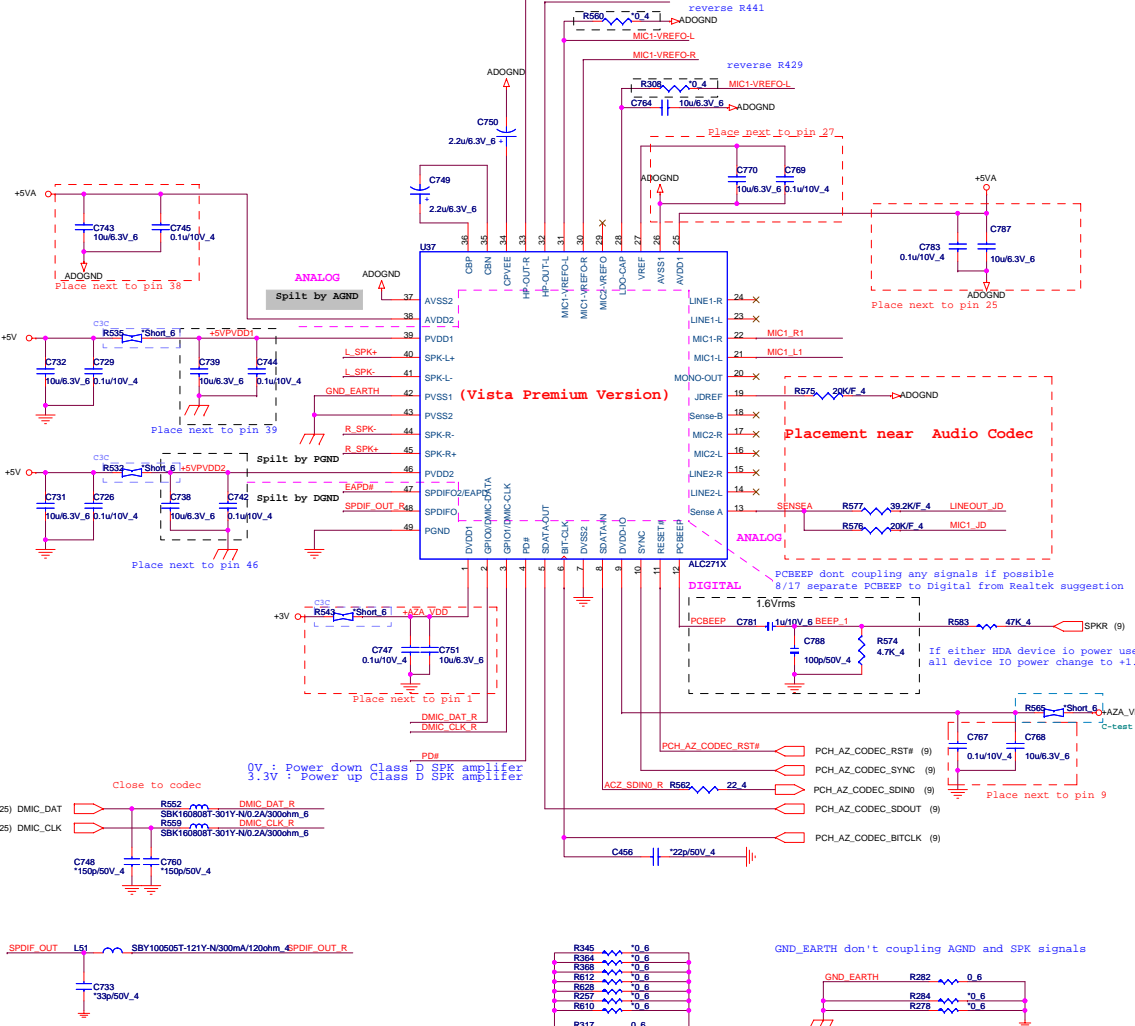

Power (ADO)

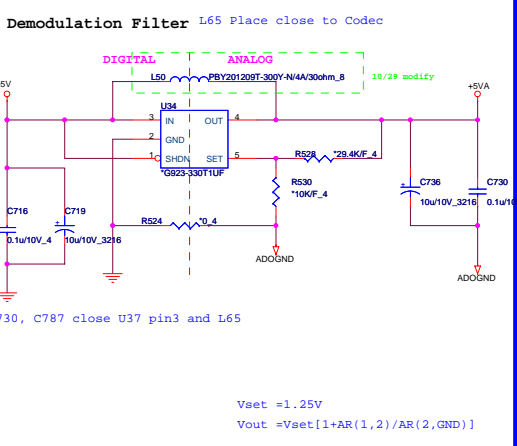

Mute(ADO)

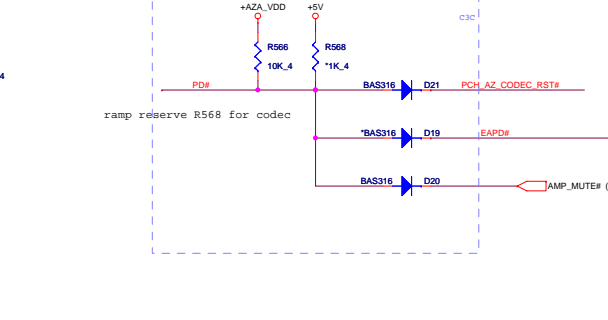

LINE-OUT/SPDIF0(AMP)

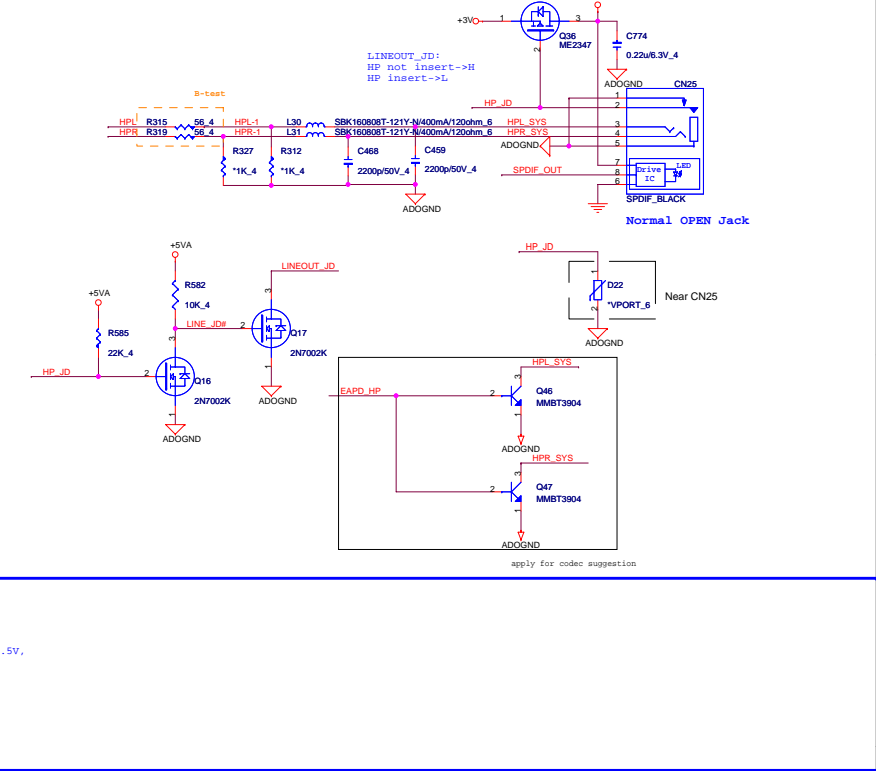

MIC(AMP)

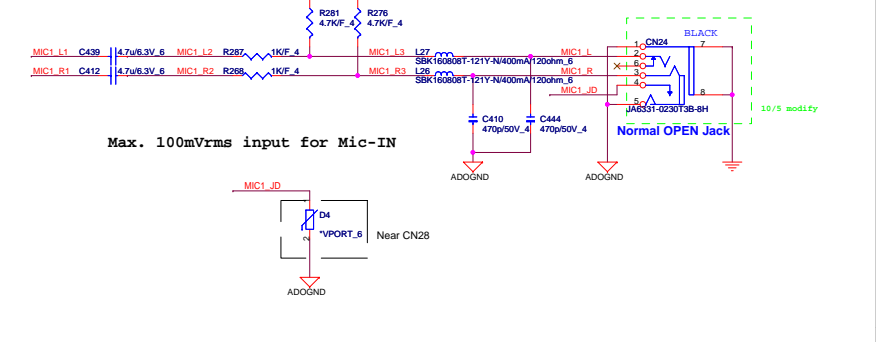

Internal Speaker(AMP)

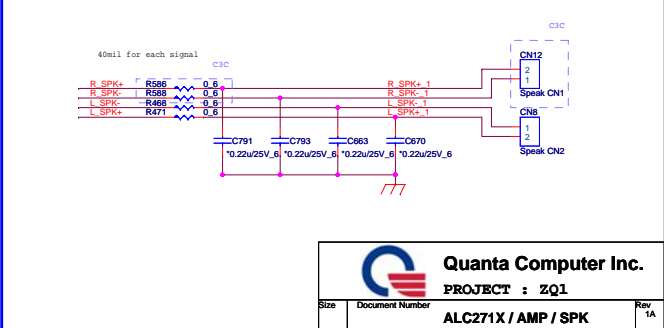

Cardreader(MMC)

4 IN 1 CARD READER (MMC)

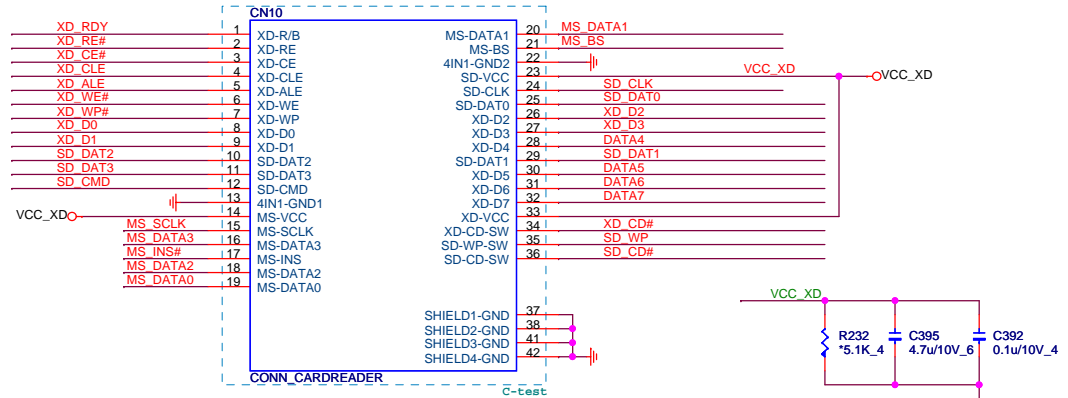

Main	DFHD36MS012
Second	DFHD38MS013

Close to CN14 pin 14 & pin23
4.7u CAP close to pin23

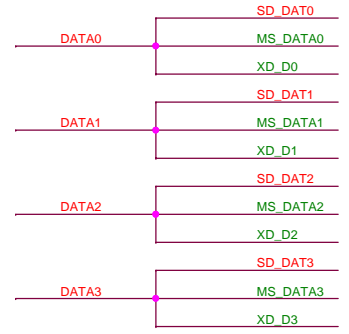

Close to connector

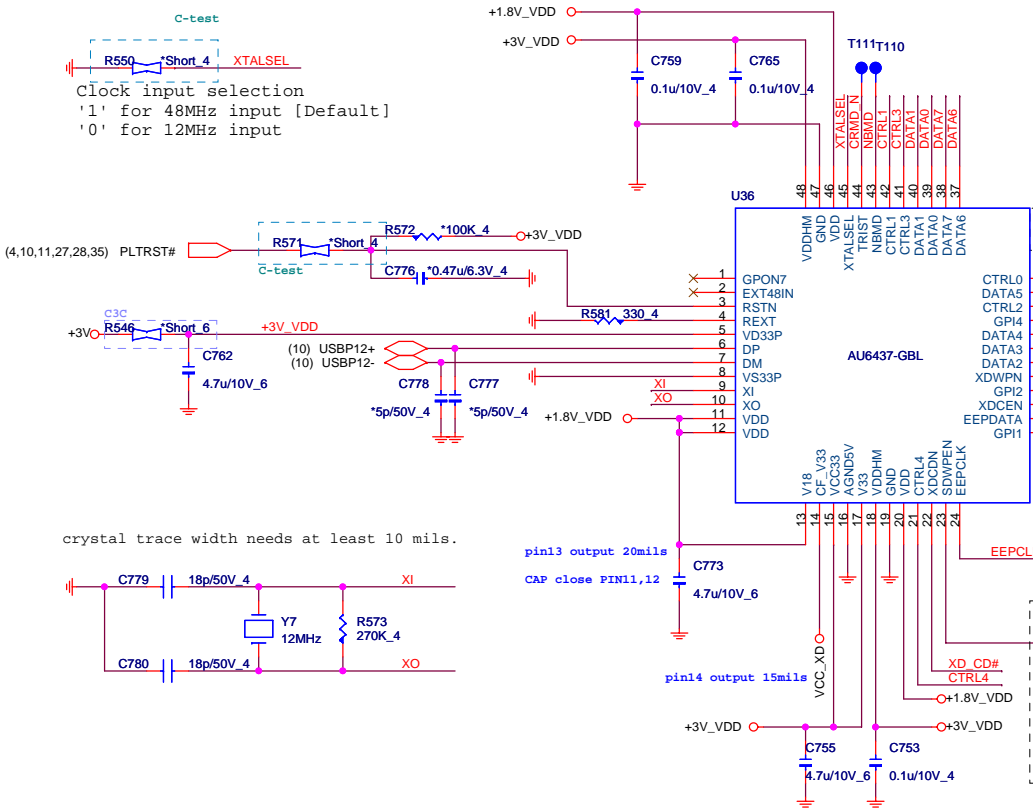
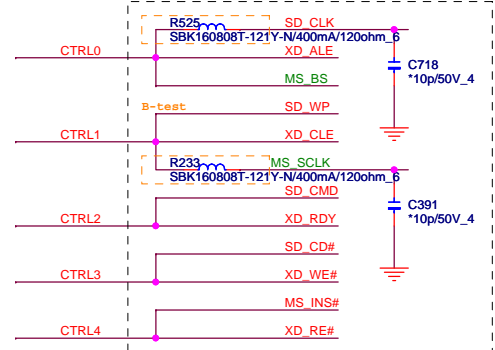

CTRL0, CTRL 1 trace length shorter ,
and surround with GND.

SD write protect
1:decided by SDWP(Default)
0:letting SD always
write-able

Clock input selection
'1' for 48MHz input [Default]
'0' for 12MHz input

crystal trace width needs at least 10 mils.

USB PORT(USB)

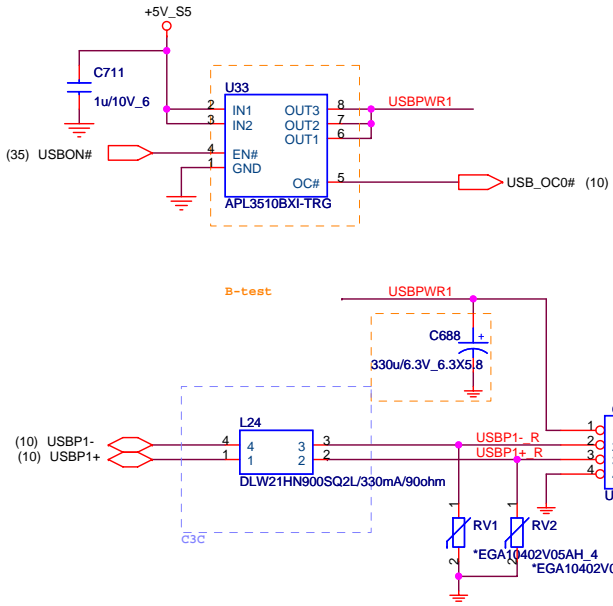

USB BOARD CONN(USB)

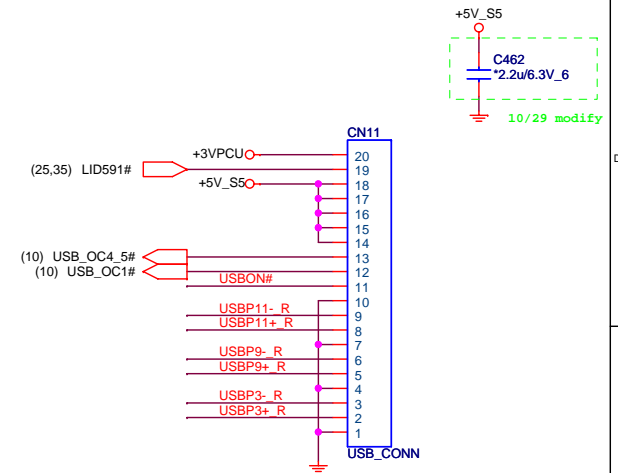
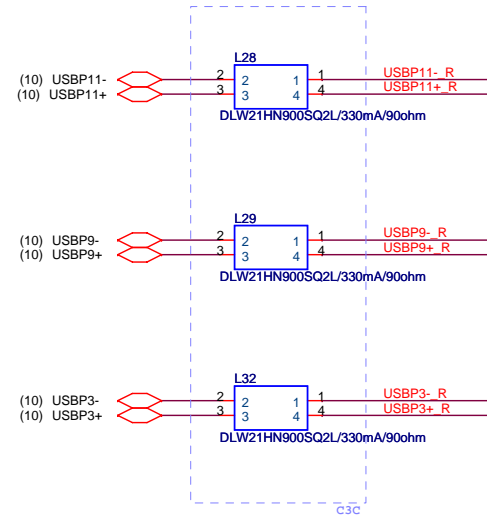

BLUETOOTH CONN(BTM)

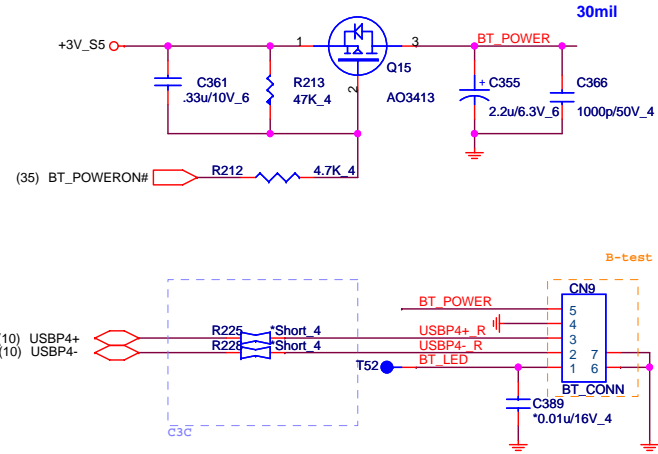

TOUCHPAD BOARD CONN(TPD)

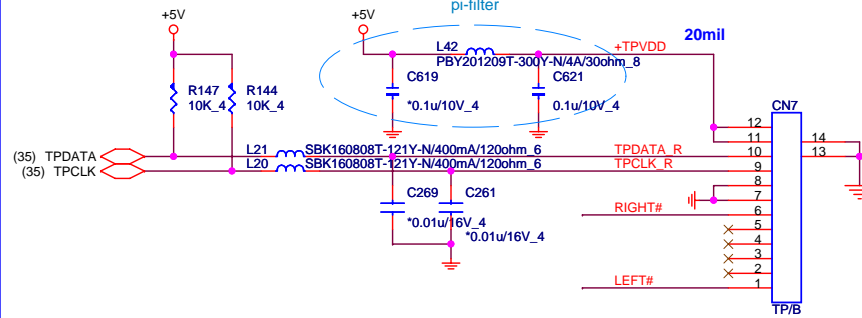

TP SWITCH(UIF)

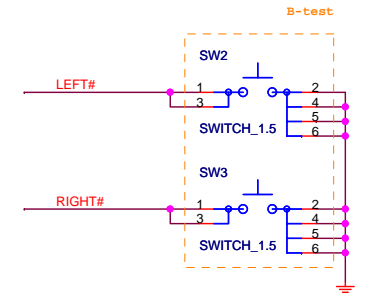

Quanta Computer Inc. PROJECT : ZQ1		Rev 1A
		Size Document Number eSATA/USB
Date: Friday, January 22, 2010		Sheet 32 of 48

POWER BOARD CONN(UIF)

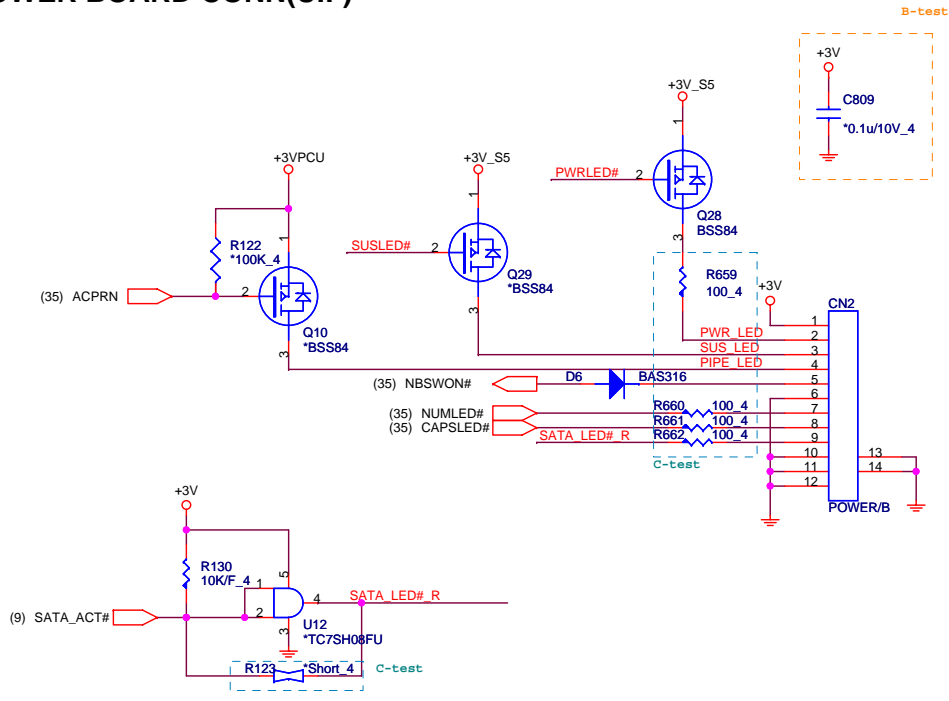

LED(UIF)

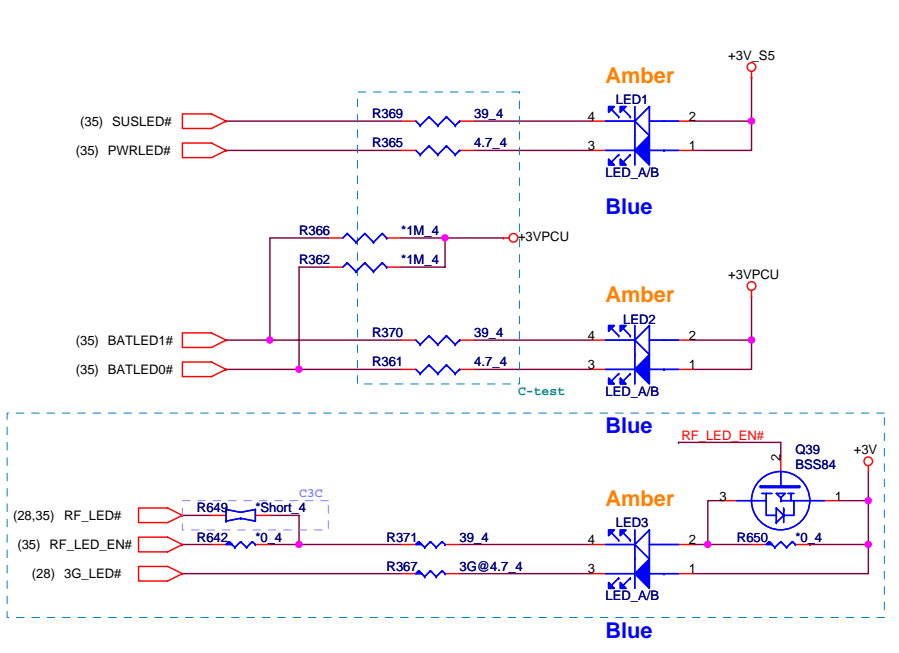

SW BOARD CONNECTOR(UIF)

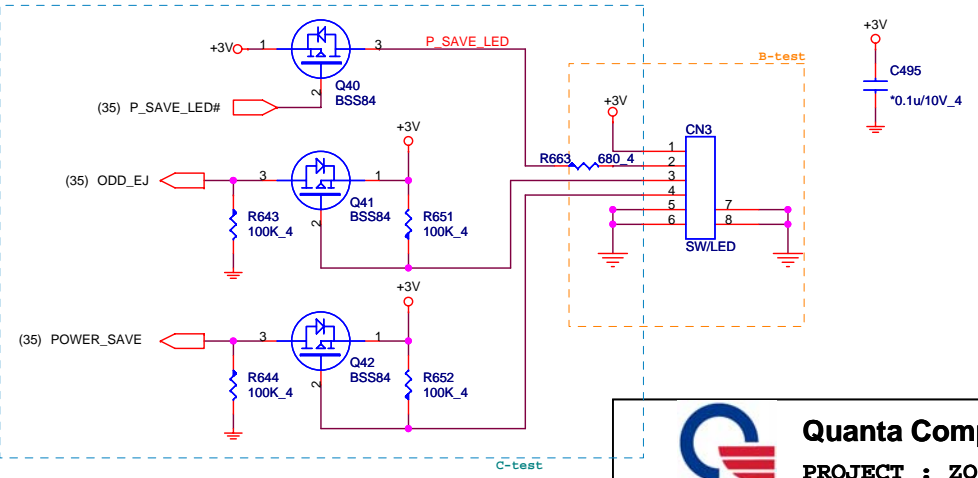

Quanta Computer Inc.
PROJECT : ZQ1

Size	Document Number	Rev
	POWER BOARD/LED/SW DB	1A
Date:	Friday, January 22, 2010	Sheet 33 of 48

14" K/B(KBC)

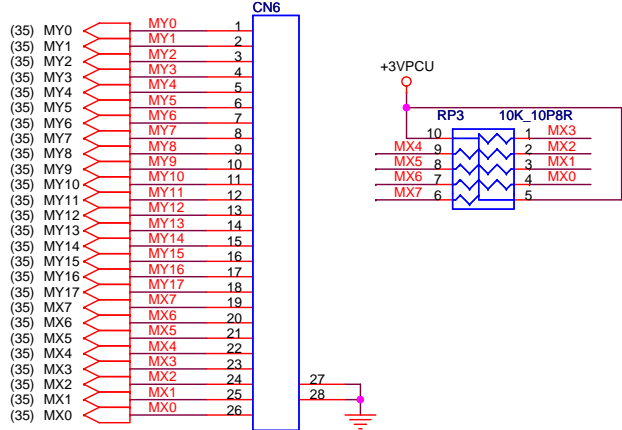
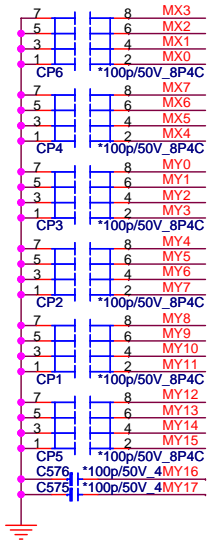

EE RETURN-PATH CAPACITORS(EMC)

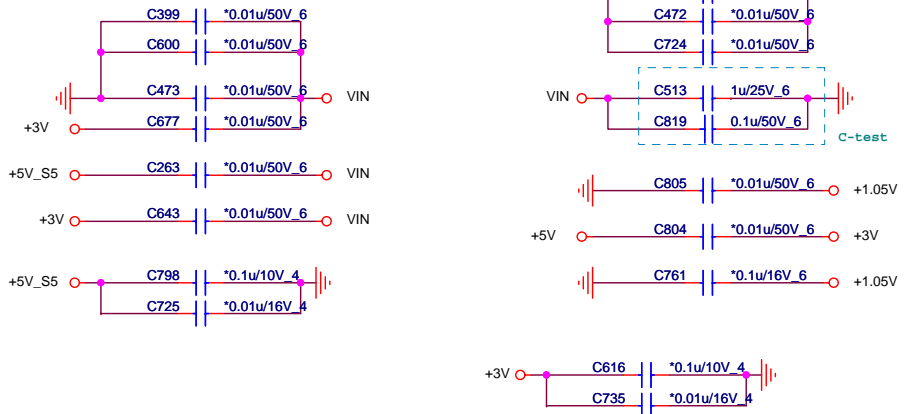

STITCHING for LPC

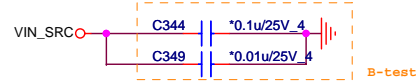

CPU FAN(THM)

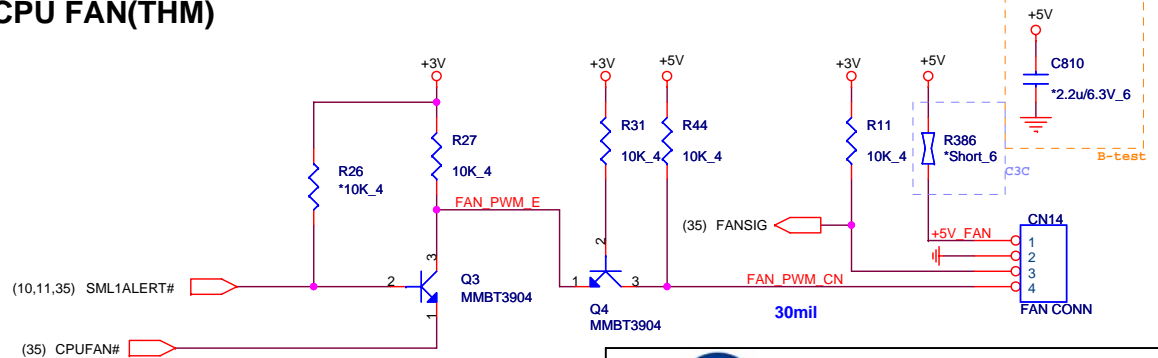



Quanta Computer Inc.
PROJECT : ZQ1

Size	Document Number	Rev
	KB/FAN/EE RETURN CAP	1A
Date: Friday, January 22, 2010		Sheet 34 of 48

EC(KBC)

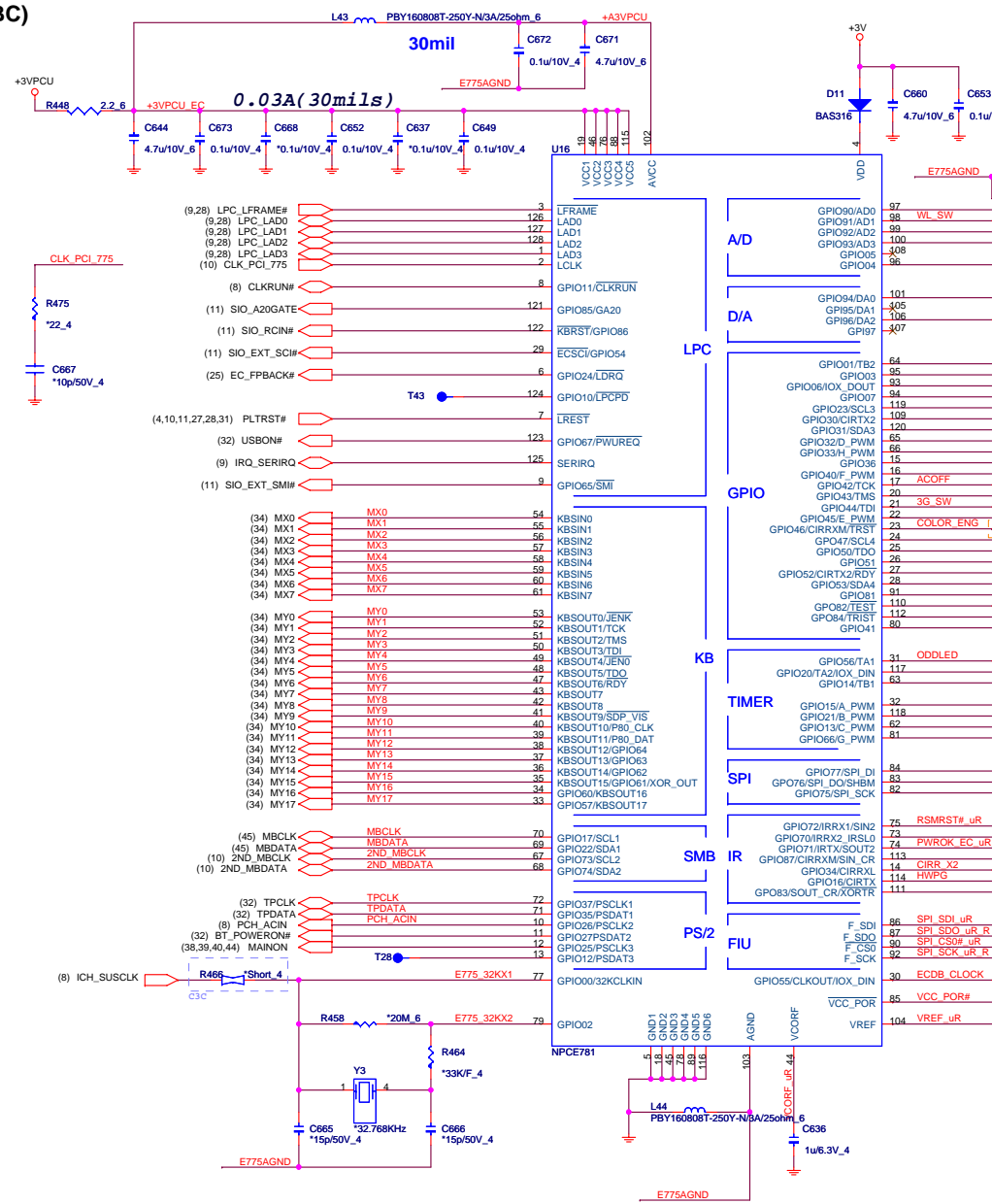

I/O ADDRESS SETTING(KBC)

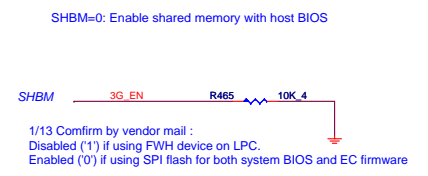

SM BUS PU(KBC)

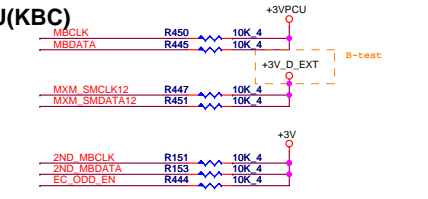

SPI FLASH(KBC)

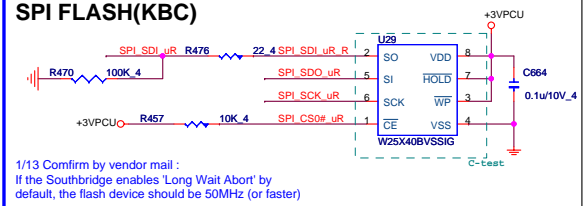

HWPG(KBC)

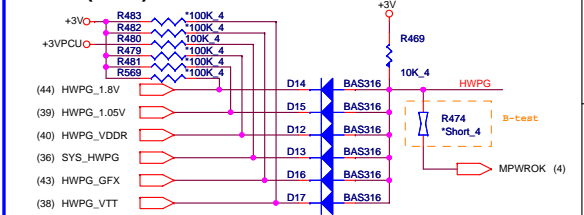

SM BUS ARRANGEMENT TABLE

SM Bus 1	Battery
SM Bus 2	PCH
SM Bus 3	EEPROM

POWER-ON Switch(KBC)

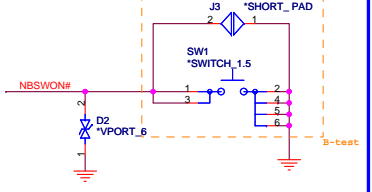

INTERNAL KEYBOARD STRIP SET(KBC)

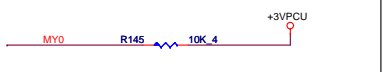

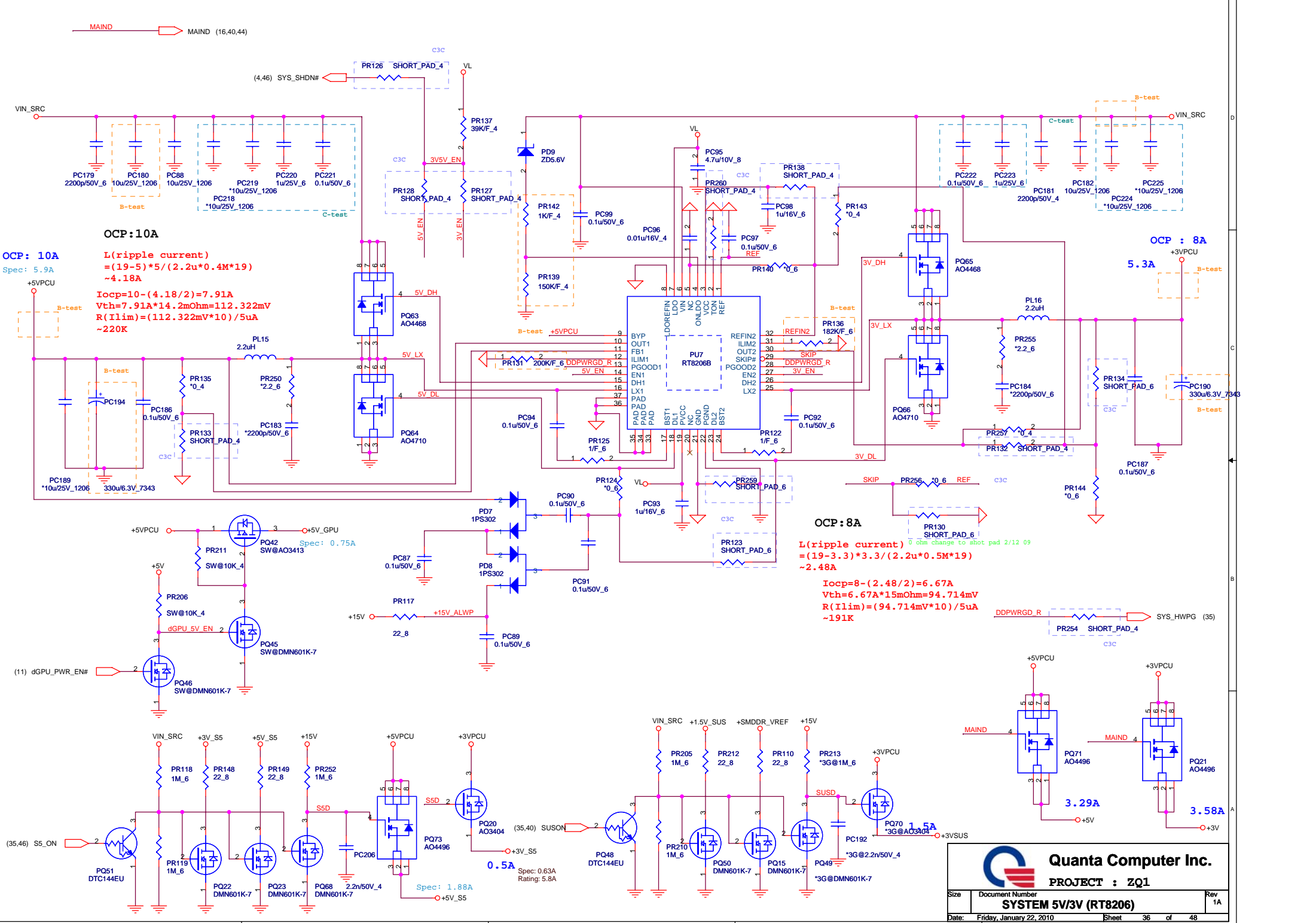

OCP: 10A
 Spec: 5.9A
 $L(\text{ripple current}) = (19-5) * 5 / (2.2u * 0.4M * 19) \sim 4.18A$
 $I_{ocp} = 10 - (4.18 / 2) = 7.91A$
 $V_{th} = 7.91A * 14.2m\Omega = 112.322mV$
 $R(I_{lim}) = (112.322mV * 10) / 5uA \sim 220K$

OCP: 8A
 $L(\text{ripple current}) = (19-3.3) * 3.3 / (2.2u * 0.5M * 19) \sim 2.48A$
 $I_{ocp} = 8 - (2.48 / 2) = 6.67A$
 $V_{th} = 6.67A * 15m\Omega = 94.714mV$
 $R(I_{lim}) = (94.714mV * 10) / 5uA \sim 191K$

Quanta Computer Inc.
 PROJECT : ZQ1

Size	Document Number	Rev
	SYSTEM 5V/3V (RT8206)	1A
Date:	Friday, January 22, 2010	Sheet 36 of 48

VID 1.2875V

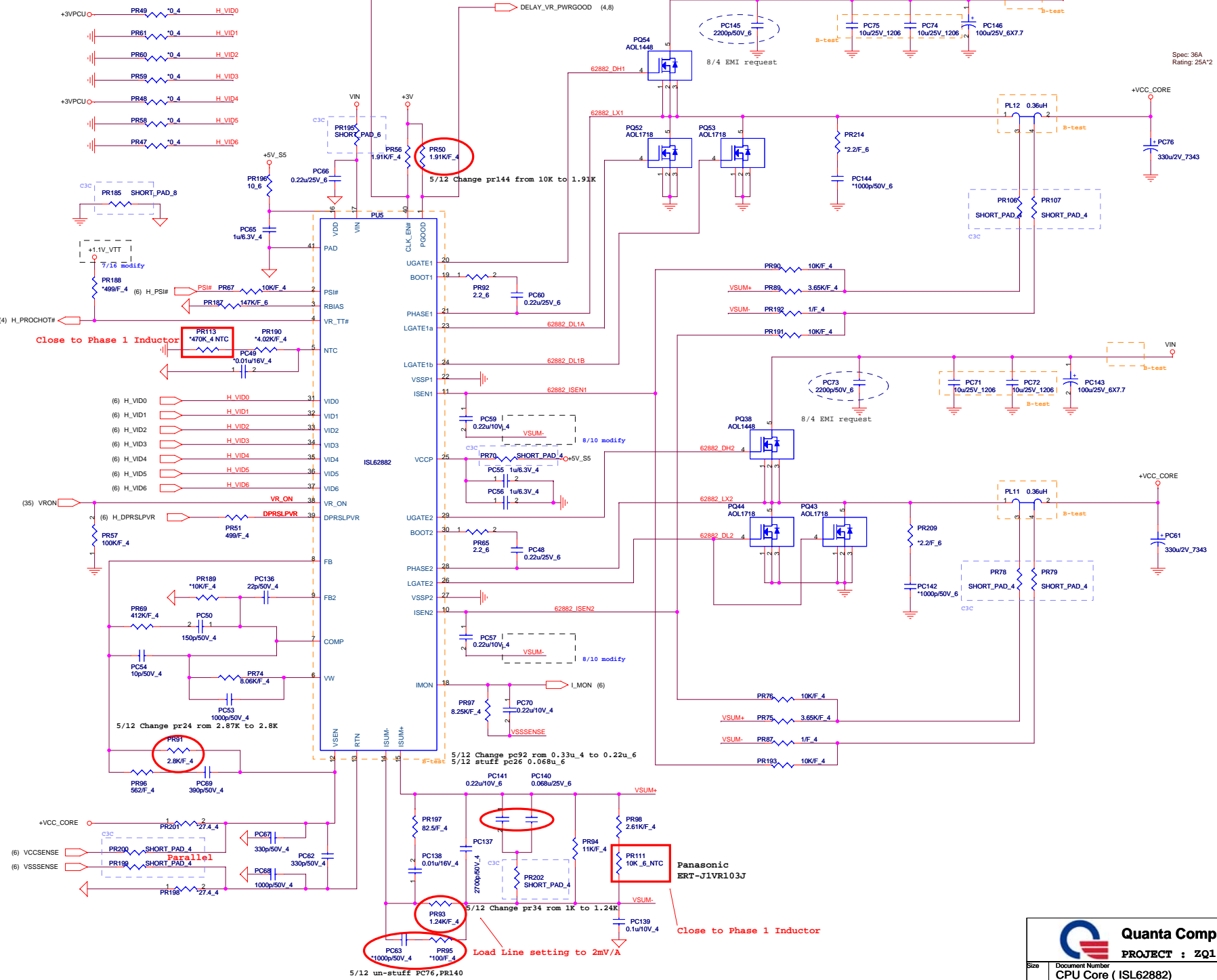

Spec: 36A
Rating: 25A*2

Quanta Computer Inc.
PROJECT : ZQ1

Size	Document Number	Rev
	CPU Core (ISL62882)	1A
Date:	Friday, January 22, 2010	Sheet 37 of 48

[PWM]

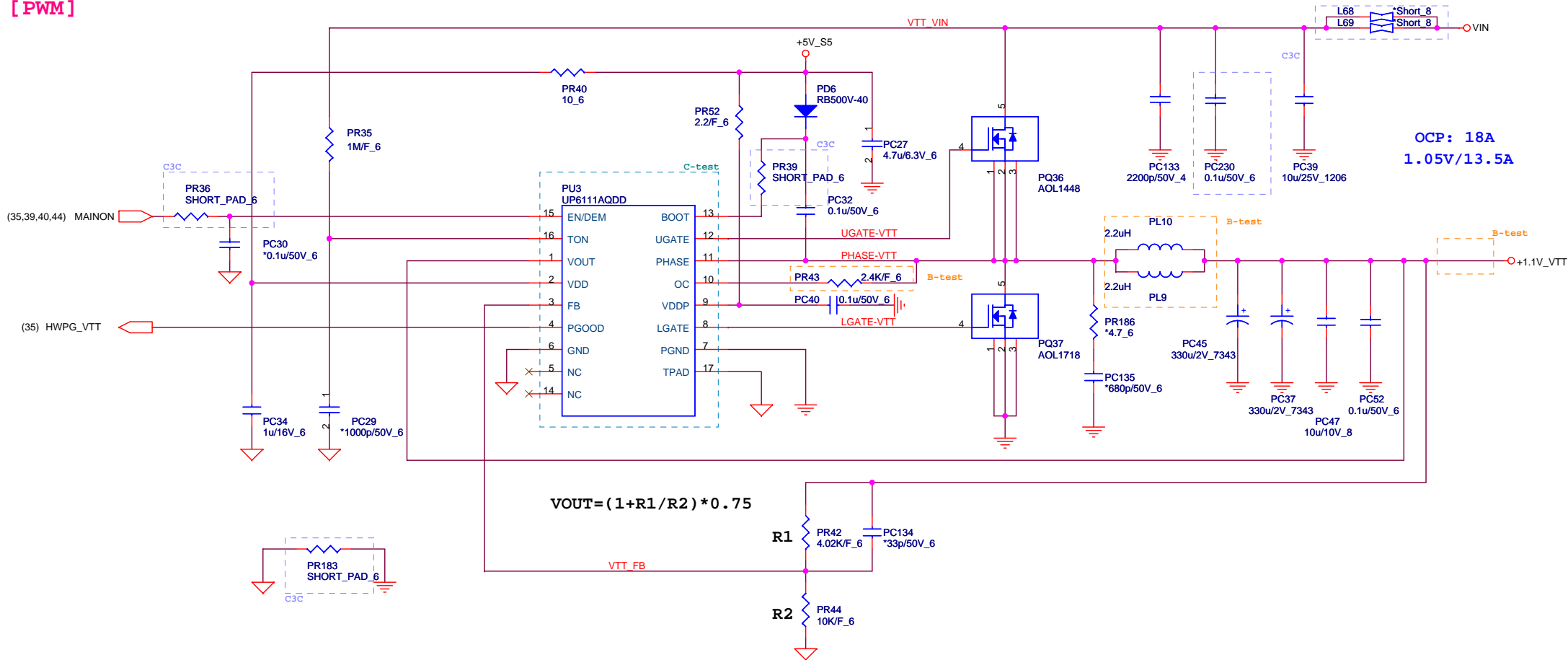

OCP: 18A
1.05V/13.5A

$$V_{OUT} = (1 + R1/R2) * 0.75$$

$TON = 3.85p * RTON * Vout / (Vin - 0.5)$
 $Frequency = Vout / (Vin * TON)$
 $TON = 3.85p * 1M * 1 / (Vin - 0.5)$
 $Frequency = 1 / (0.0036767) = 272K$

AO1718 $R_{dson} = 3 \sim 4.3m\Omega$
 $L(\text{ripple current}) = (19 - 1.05) * 1.05 / (1u * 272k * 19) \sim 3.64A$
 $4.3m * 18 = RILIM * 20uA$
 $RILIM = 3.87K \text{ --- } 3.92K$

 Quanta Computer Inc. PROJECT : ZQ1				
			Size	Document Number
			+VTT (UP6111A)	1A
Date:	Friday, January 22, 2010	Sheet	38	of 48

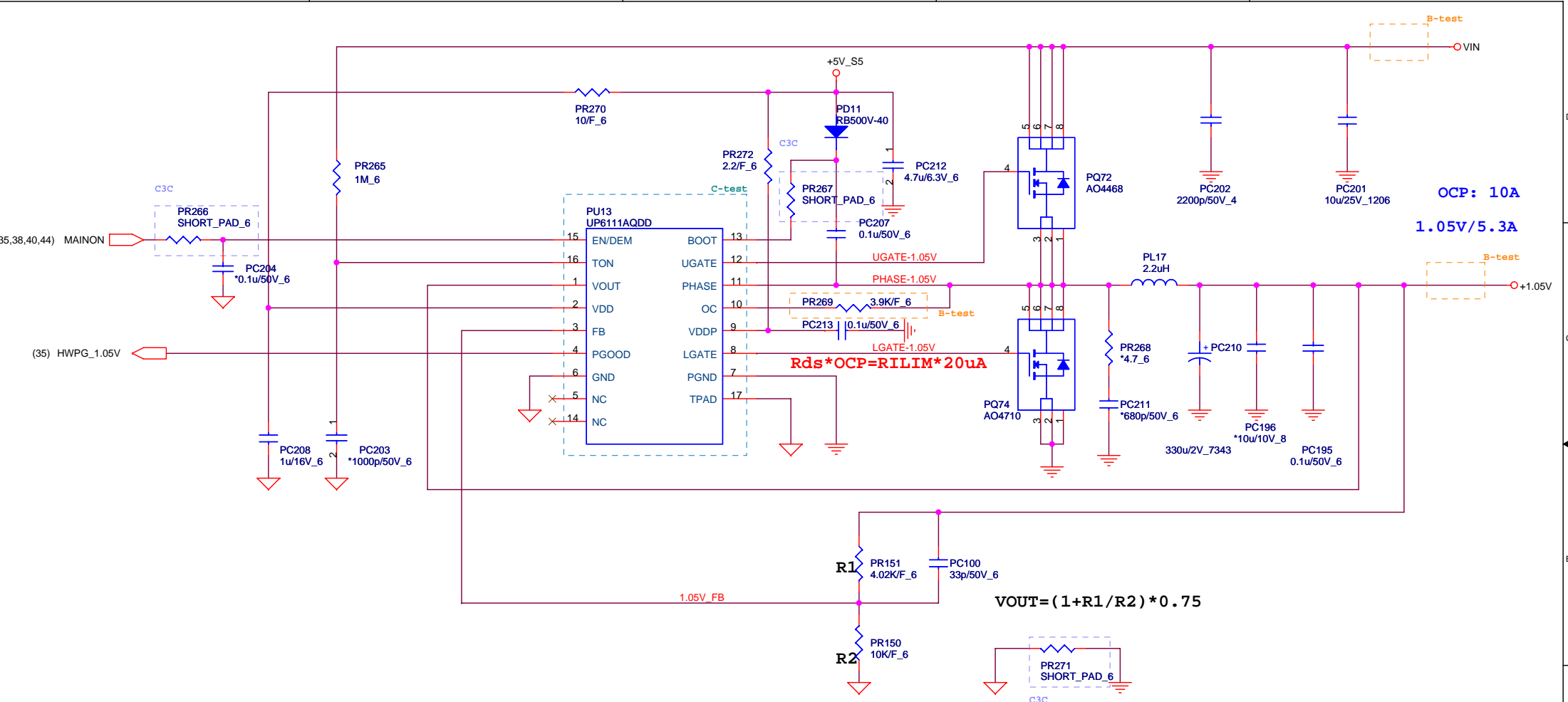

OCP: 10A
1.05V/5.3A

$$V_{OUT} = (1 + R1/R2) * 0.75$$

$$T_{ON} = 3.85p * R_{TON} * V_{out} / (V_{in} - 0.5)$$

$$Frequency = V_{out} / (V_{in} * T_{ON})$$

$$T_{ON} = 3.85p * 1M * 1 / (V_{in} - 0.5)$$

$$Frequency = 1 / (0.0036767) = 272K$$

AO4710 $R_{dson} = 11.7 \sim 14.2m\Omega$

L(ripple current)
 $= (19 - 1.05) * 1.05 / (1u * 272k * 19)$
 $\sim 3.646A$

$14.2m * 10 = RILIM * 20uA$

$RILIM = 7.1K \text{ --- } 7.15K$

 Quanta Computer Inc. PROJECT : ZQ1		Rev
		1A
Size	Document Number	
VCCP 1.05V(UP6111A)		
Date:	Friday, January 22, 2010	Sheet 39 of 48

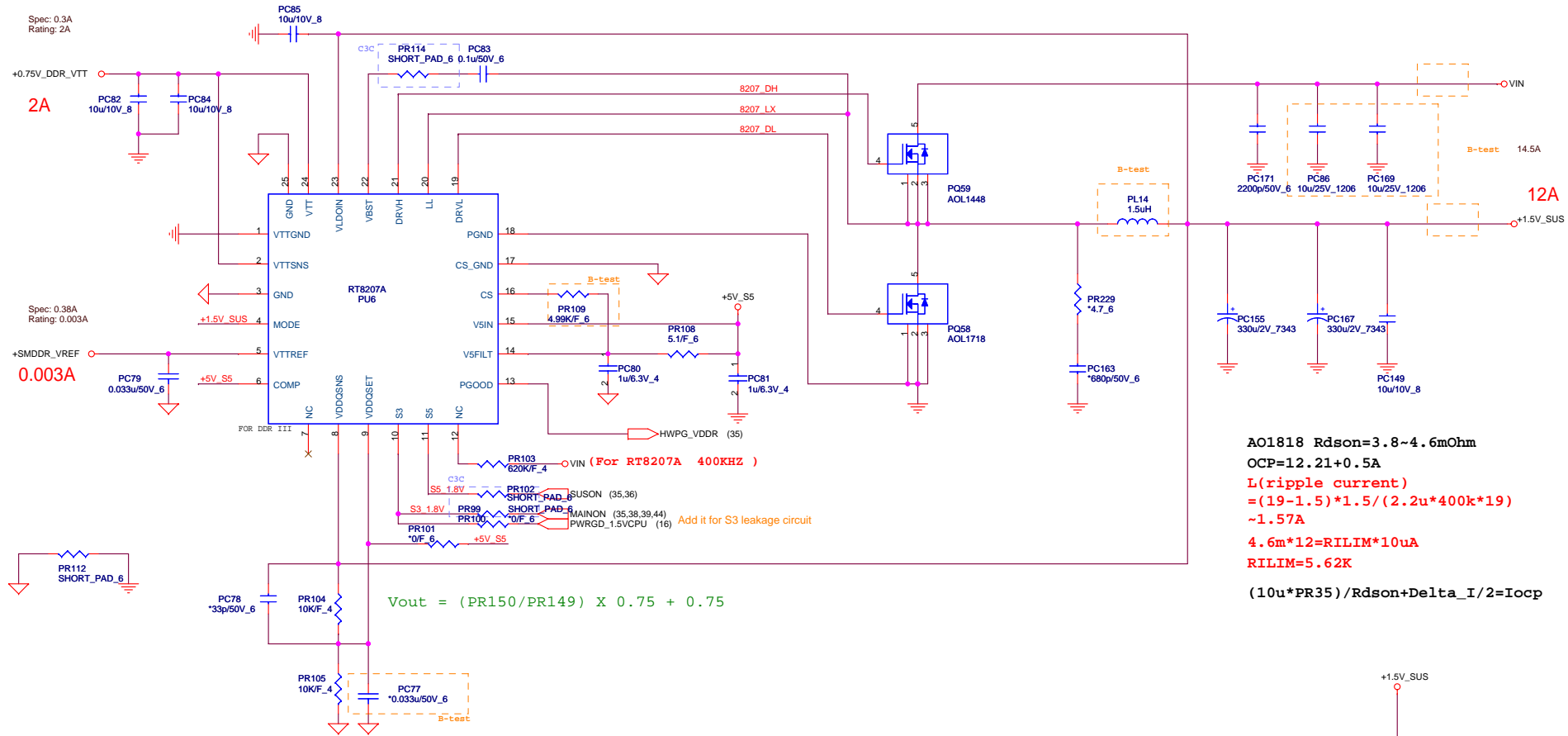

AO1818 $R_{dson}=3.8\sim 4.6m\Omega$
OCP=12.21+0.5A
L(ripple current)
 $= (19-1.5) * 1.5 / (2.2u * 400k * 19)$
 $\sim 1.57A$
 $4.6m * 12 = R_{ILIM} * 10uA$
RILIM=5.62K
 $(10u * PR35) / R_{dson} + \Delta I / 2 = I_{ocp}$

$$V_{out} = (PR150/PR149) \times 0.75 + 0.75$$

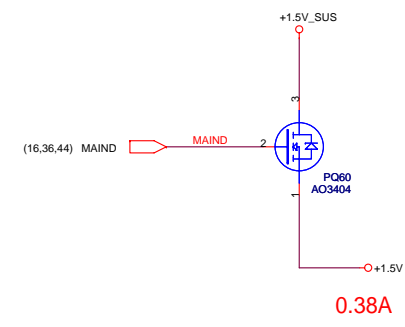
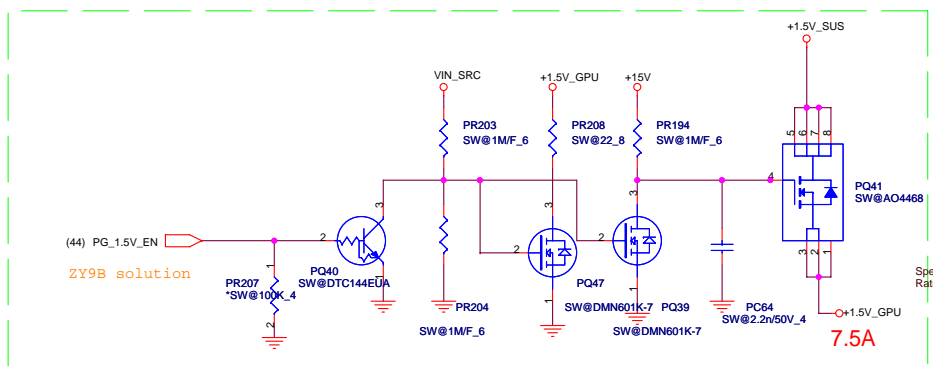

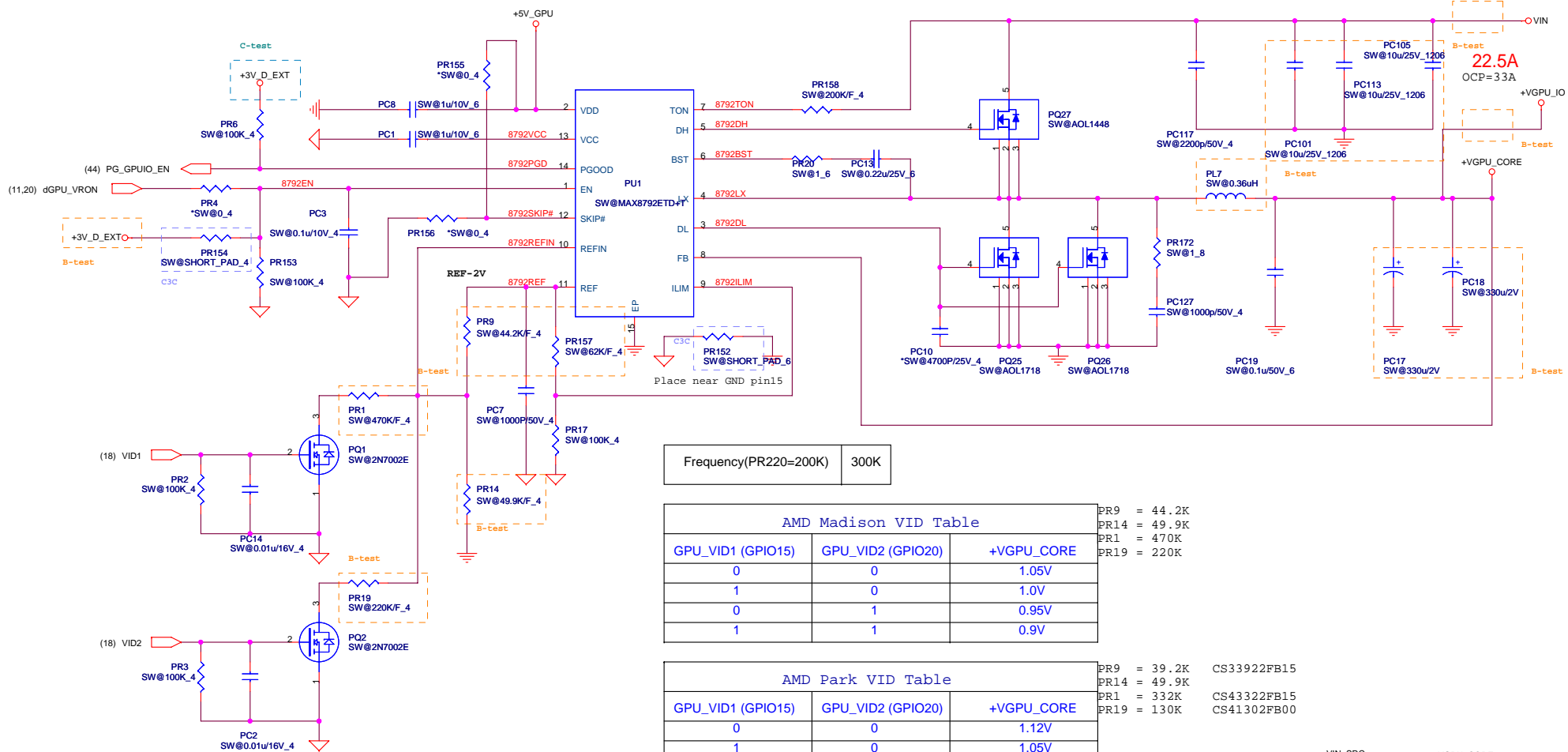

Frequency(PR220=200K) 300K

AMD Madison VID Table

GPU_VID1 (GPIO15)	GPU_VID2 (GPIO20)	+VGPU_CORE
0	0	1.05V
1	0	1.0V
0	1	0.95V
1	1	0.9V

PR9 = 44.2K
 PR14 = 49.9K
 PR1 = 470K
 PR19 = 220K

AMD Park VID Table

GPU_VID1 (GPIO15)	GPU_VID2 (GPIO20)	+VGPU_CORE
0	0	1.12V
1	0	1.05V
0	1	0.95V
1	1	0.9V

PR9 = 39.2K CS33922FB15
 PR14 = 49.9K
 PR1 = 332K CS43322FB15
 PR19 = 130K CS41302FB00

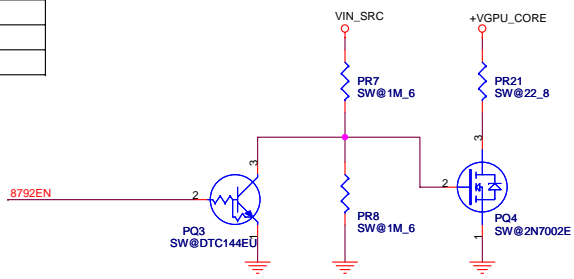

- (6) GFX_VID0
- (6) GFX_VID1
- (6) GFX_VID2
- (6) GFX_VID3
- (6) GFX_VID4
- (6) GFX_VID5
- (6) GFX_VID6

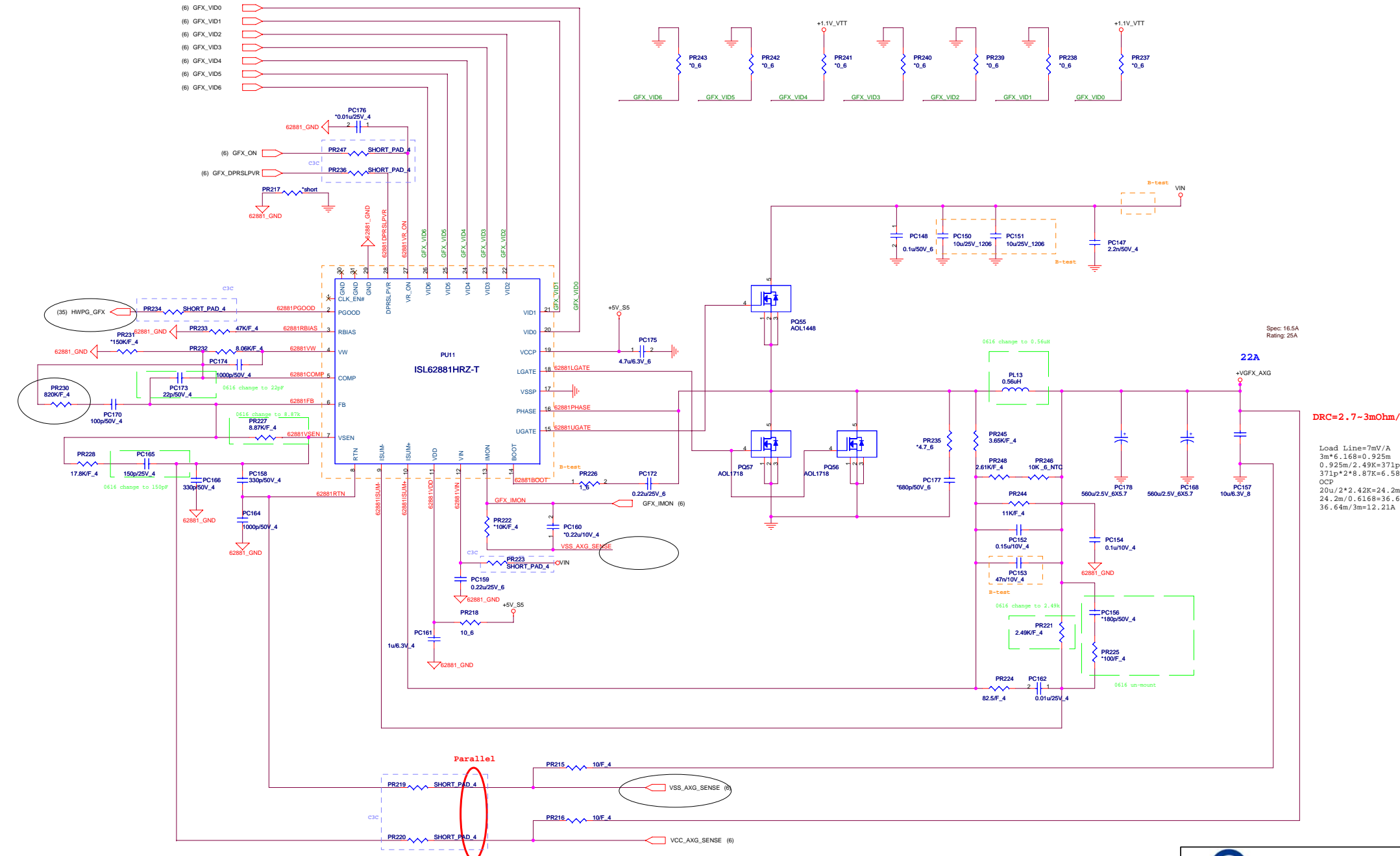

Spec: 16.5A
Rating: 25A

DRC=2.7~3mOhm/2
Load Line=7mV/A
3m*6.168=0.925m
0.925m/2.49K=371p
371p*2*6.87K=6.58m
OCP
20u/2*2.42K=24.2m
24.2m/0.6168=36.64m
36.64m/3m=12.21A

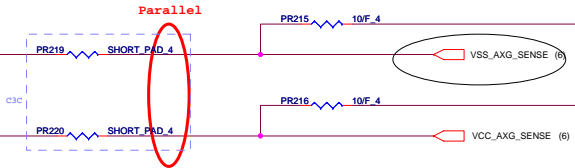

Quanta Computer Inc.
PROJECT : ZQ1

Size	Document Number	Rev
	+V GFX_AXG (ISL62881)	1A

Date: Friday, January 22, 2010 Sheet 43 of 48

1. Level 1 Environment-related Substances should NEVER be Used.
2. Purchase ink, paint, wire rods, and Molding resins only from the business Partners that Sony approves as Green Partners.

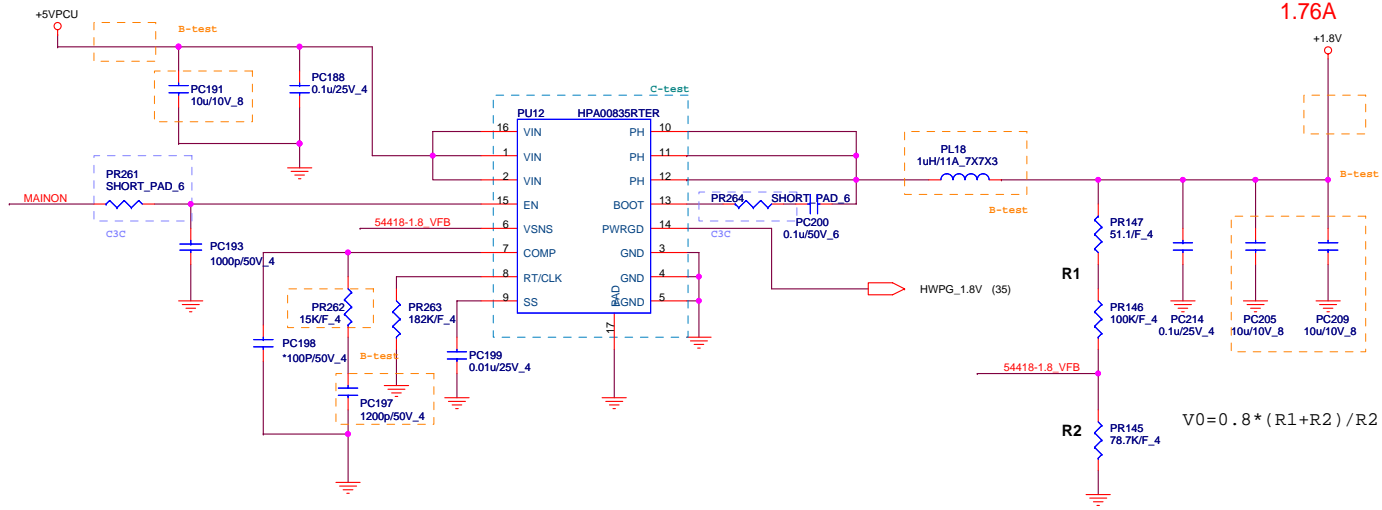

1.76A

Spec: 1.32A
Rating: 6A

$$V0 = 0.8 * (R1 + R2) / R2$$

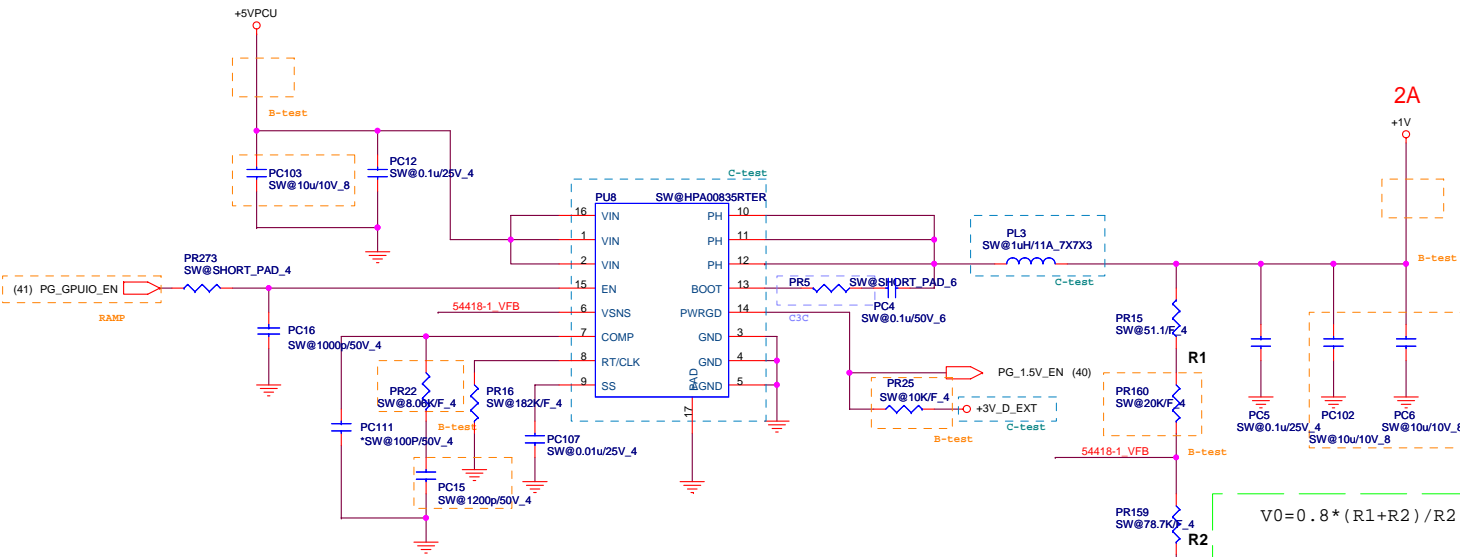

2A

Spec: 1.5A
Rating: 6A

$$V0 = 0.8 * (R1 + R2) / R2$$

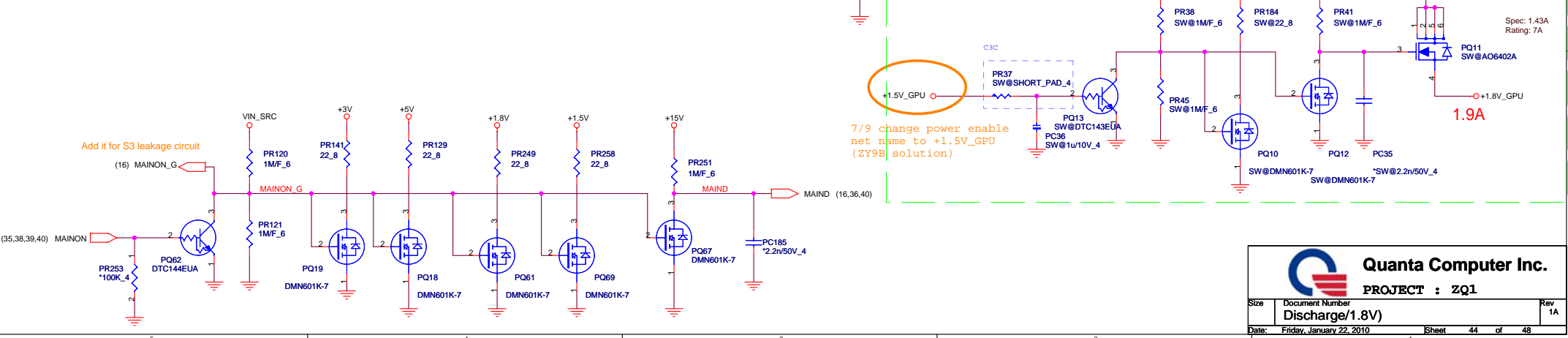

1.9A

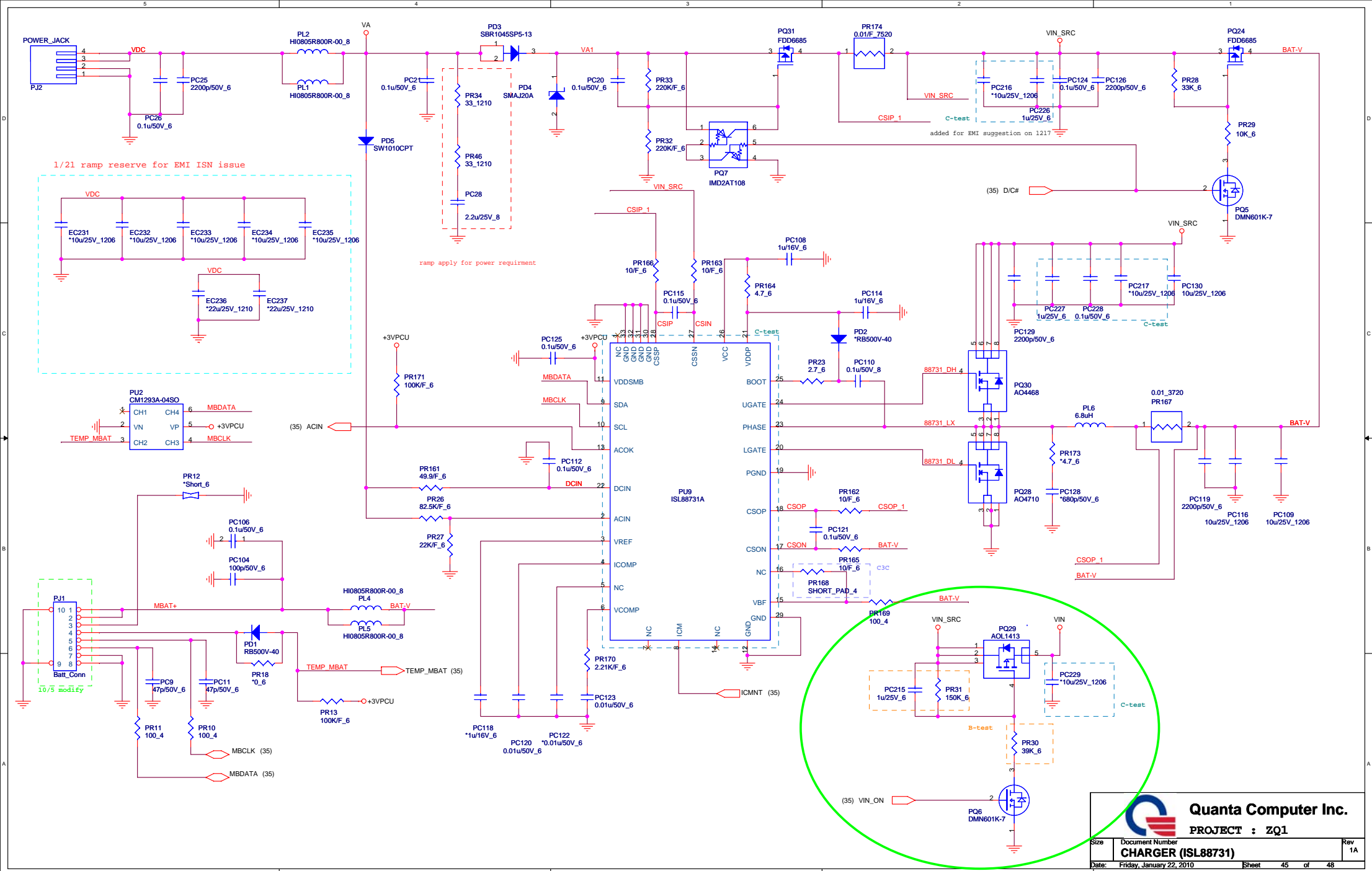

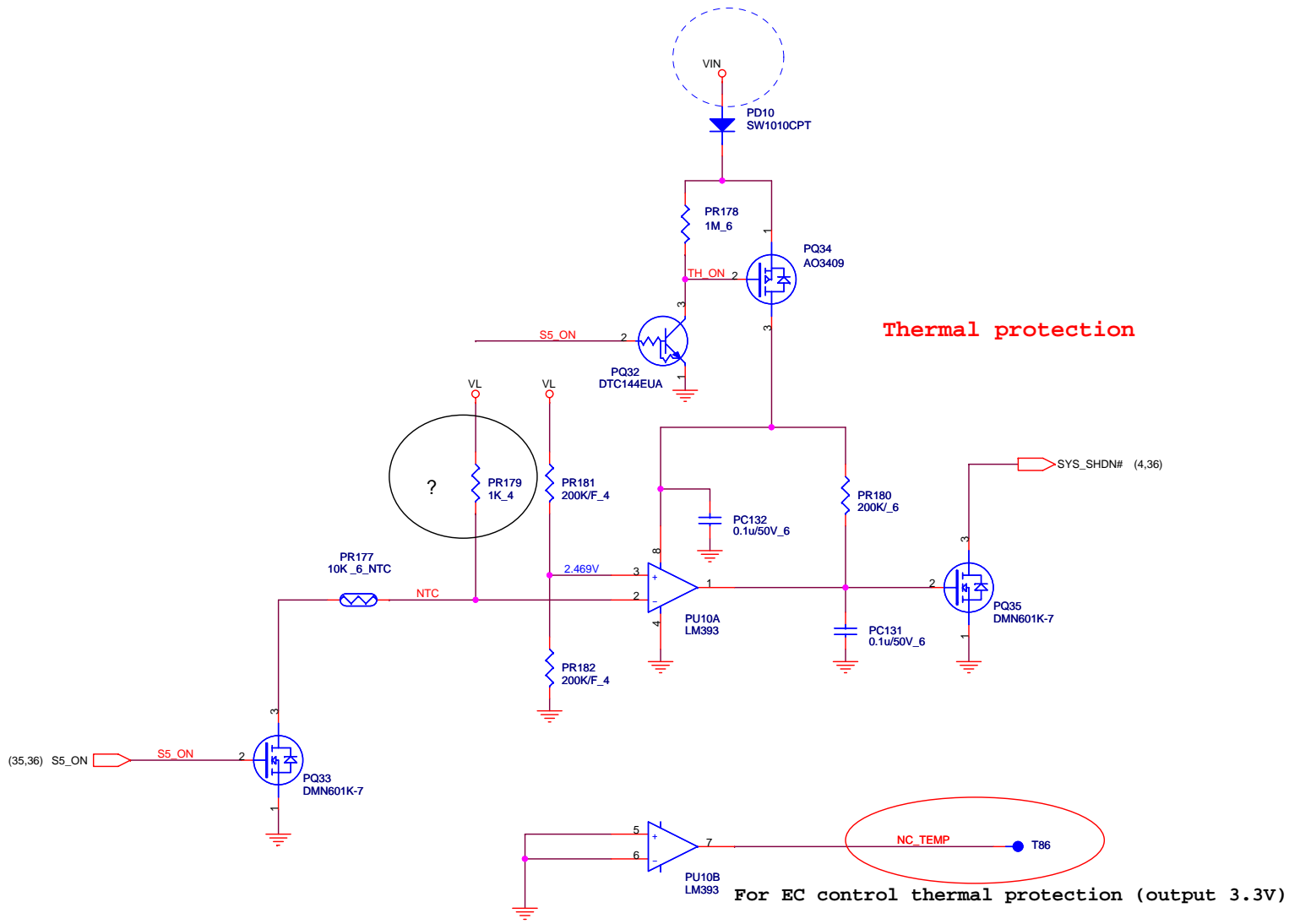

Thermal protection

For EC control thermal protection (output 3.3V)

 Quanta Computer Inc. PROJECT : ZQ1		Rev
		1A
Size	Document Number	
Thermal Protection		
Date:	Friday, January 22, 2010	Sheet 46 of 48