

*DEMAIS COMPONENTES FORNECIDOS*

Código	Descrição peça	Nº
PCI PRINCIPAL		
710314	FILTRO SAW YXB4406S, X6764N(SIP5K)	U30
710315	TUNER VA1P1BF8402 SHARP	U51
710316	CI 1117-1.8 (TO252- 3L) (SMD)	U39
708367	CI 1117-3.3 (TO252-3L) (SMD)	U38
706779	CI 78M05 (SOT252) (SMD)	U13
705479	CI 1117-1.2 (SOT223) (SMD)	U14
710317	CI TC90157FG (QFP64)(SMD)	U16
710318	CI MSH9000 (SMD 40P)	U3
707920	CI 74HC4052D (SO-16) (SMD)	U23
705522	CI 1117-2.5 (SOT223) (SMD)	U20, U36
704492	CI 1117-3.3 (SOT223) (SMD)	U12,U37
710319	CI SM8005 (SSOT23-6)	U50
709683	TRANSISTOR 2SC2216 (TO-92) (PTH)	Q405
PCI FONTE		
710320	CI OB2262MP,LD7535B (SOT-26)(SMD)	IC1
710321	CI L6599DTR (SOC-16)	U2
710322	CI P1403EV8,AP4435 (SOP-8)(SMD)	Q11
710323	CI HPA00721, UCC28060 (SOC16)(SMD)	U1
701633	CI 817 (DIP-4)(PTH)	BP1, PC1, PC2, PC4
701632	CI TL431,KA431 (TO-92) (PTH)	BU1, IC2
710324	RETIFICADOR T10XB60 10A (SIP)	BD1
710325	TRANSISTOR K3568, FQPF13N50(TO220)	BQ1, BQ2
710326	TRANSISTOR F2HMK60,2SK3767(TO-220)	Q9
710327	FUSIVEL 6.3A 250V	F2
710328	TRANSISTOR 2N4401 (TO-92)(PTH)	Q5
710329	TRANSISTOR F13NK50Z 12A (TO-220FP)	Q3, Q4
710330	TERMISTOR SCK 2R58 (8A) NTC	RT1
710331	DIODO FSU05B60 5A (TO-220)	D1,D2
710332	DIODO B2045G, MBRF2045CT (TO-220F)	D7,D8
710333	DIODO B20100G, FCH20A10 (TO-220F)	D9,D10
710334	CAPACITOR 120uF/450V	EC2

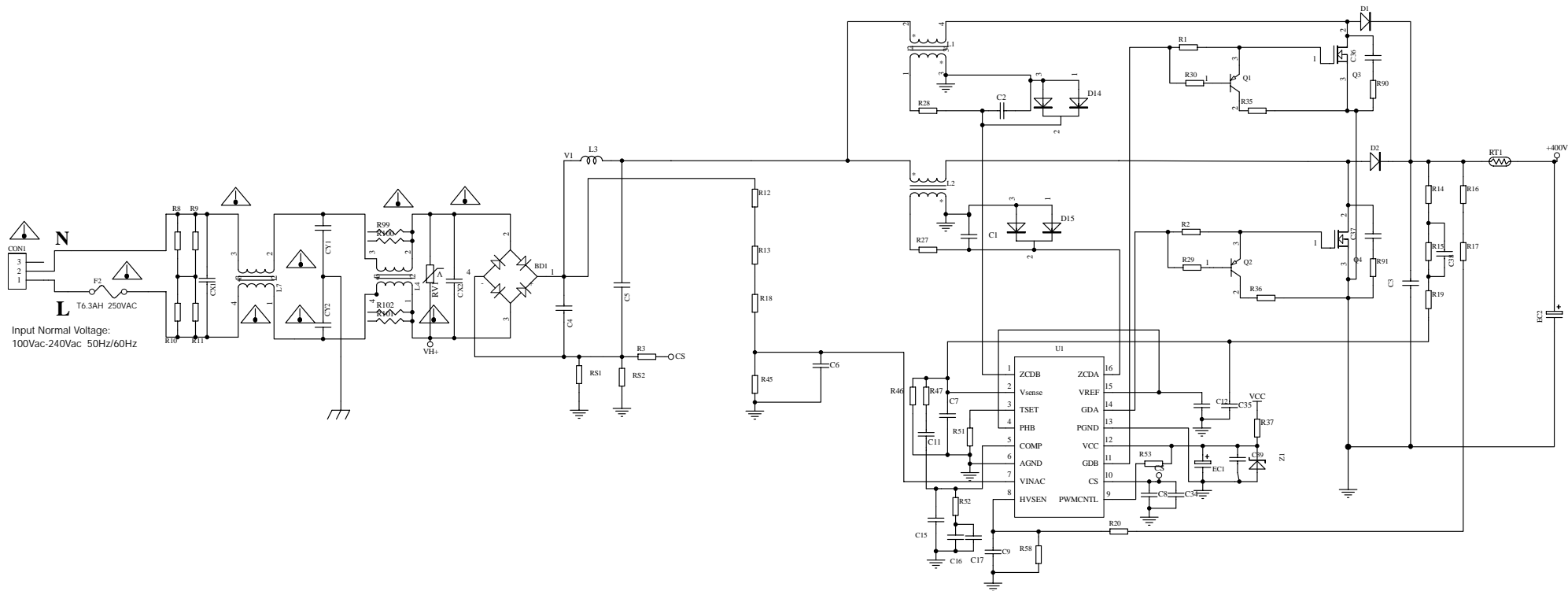

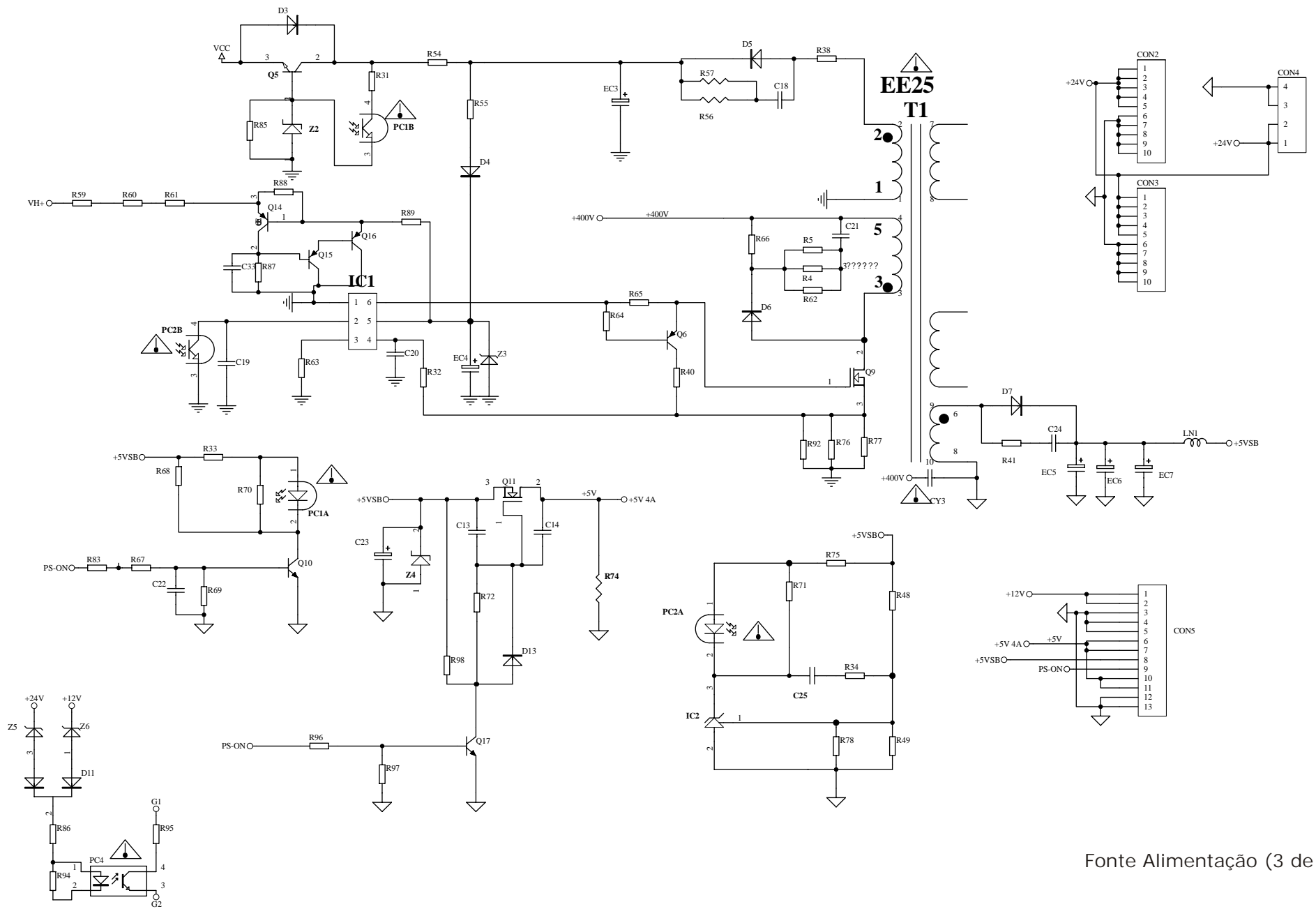



Fonte Alimentação (3 de 3)