

LG Electronics Inc PC Division			
TITLE		D3 ENTRY NORTHWOOD (1 OF 3)	
PART NO	6870B	REV	REV 0.7
DATE	2003.2.26	SHEET	1 of 60

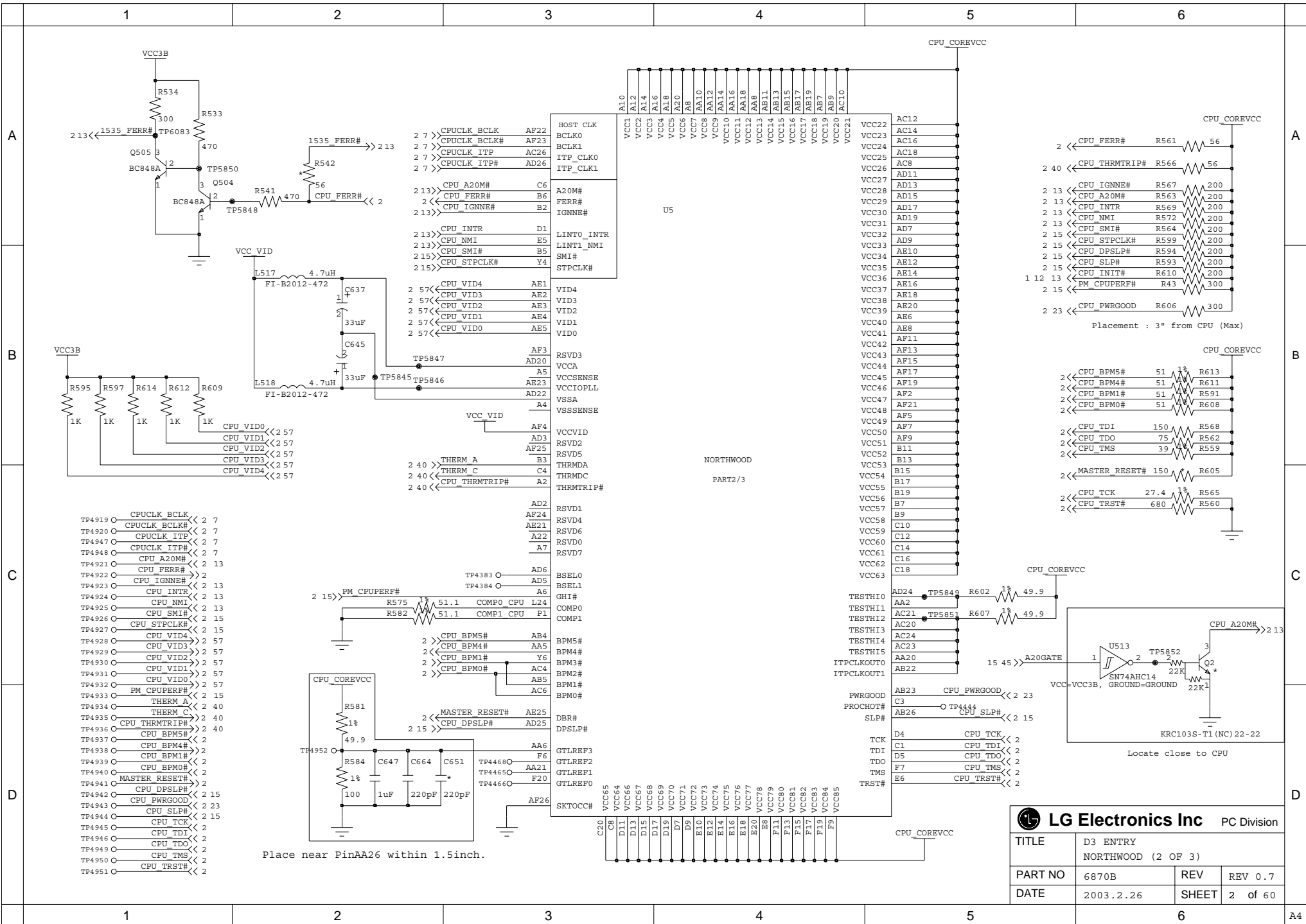

LG Electronics Inc PC Division

TITLE	D3 ENTRY		
	NORTHWOOD (2 OF 3)		
PART NO	6870B	REV	REV 0.7
DATE	2003.2.26	SHEET	2 of 60

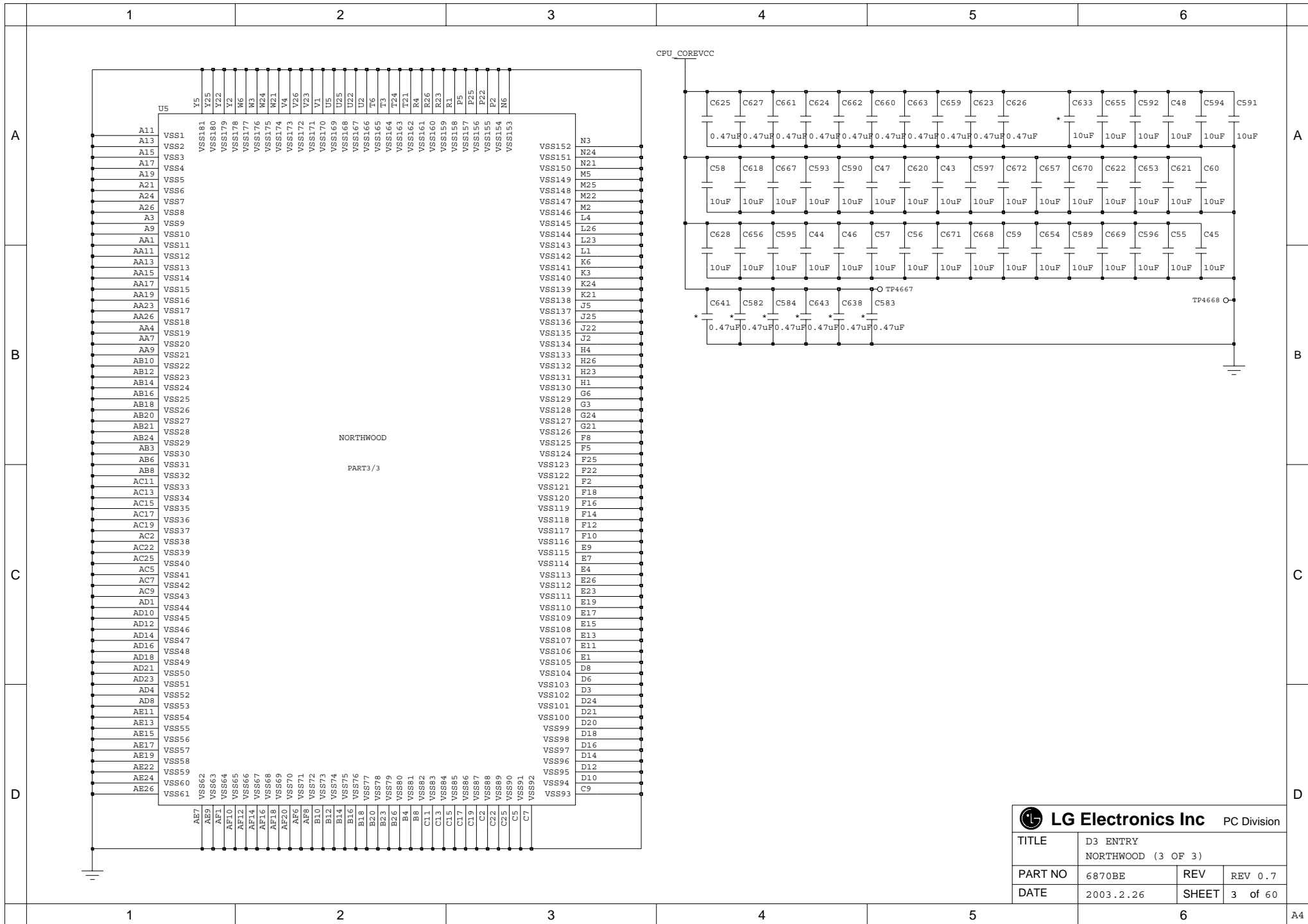

LG Electronics Inc PC Division

TITLE	D3 ENTRY NORTHWOOD (3 OF 3)		
PART NO	6870BE	REV	REV 0.7
DATE	2003.2.26	SHEET	3 of 60

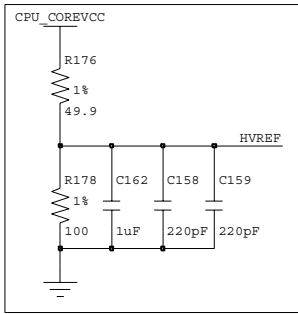
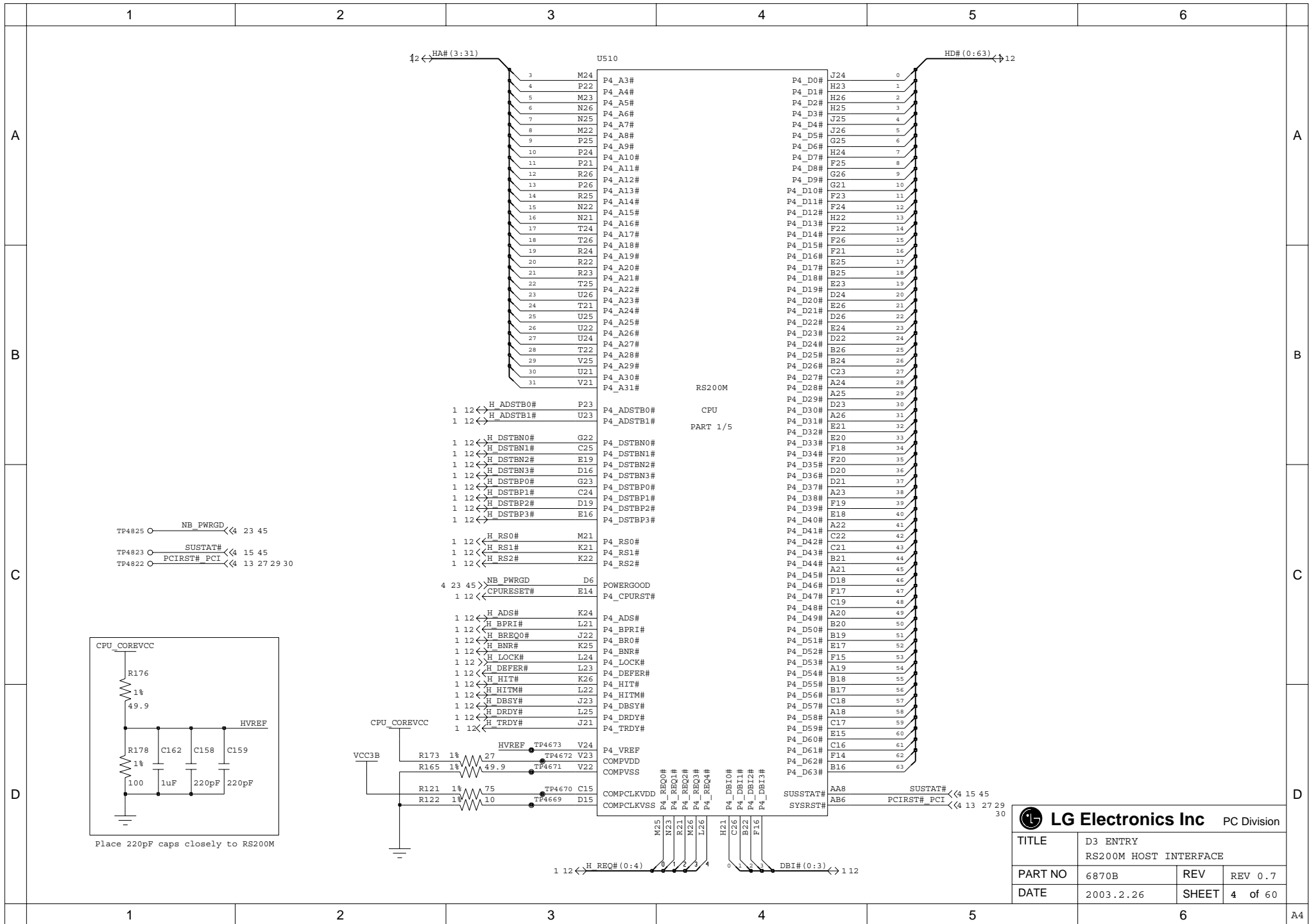

Place 220pF caps closely to RS200M

LG Electronics Inc PC Division			
TITLE	D3 ENTRY RS200M HOST INTERFACE		
PART NO	6870B	REV	REV 0.7
DATE	2003.2.26	SHEET	4 of 60

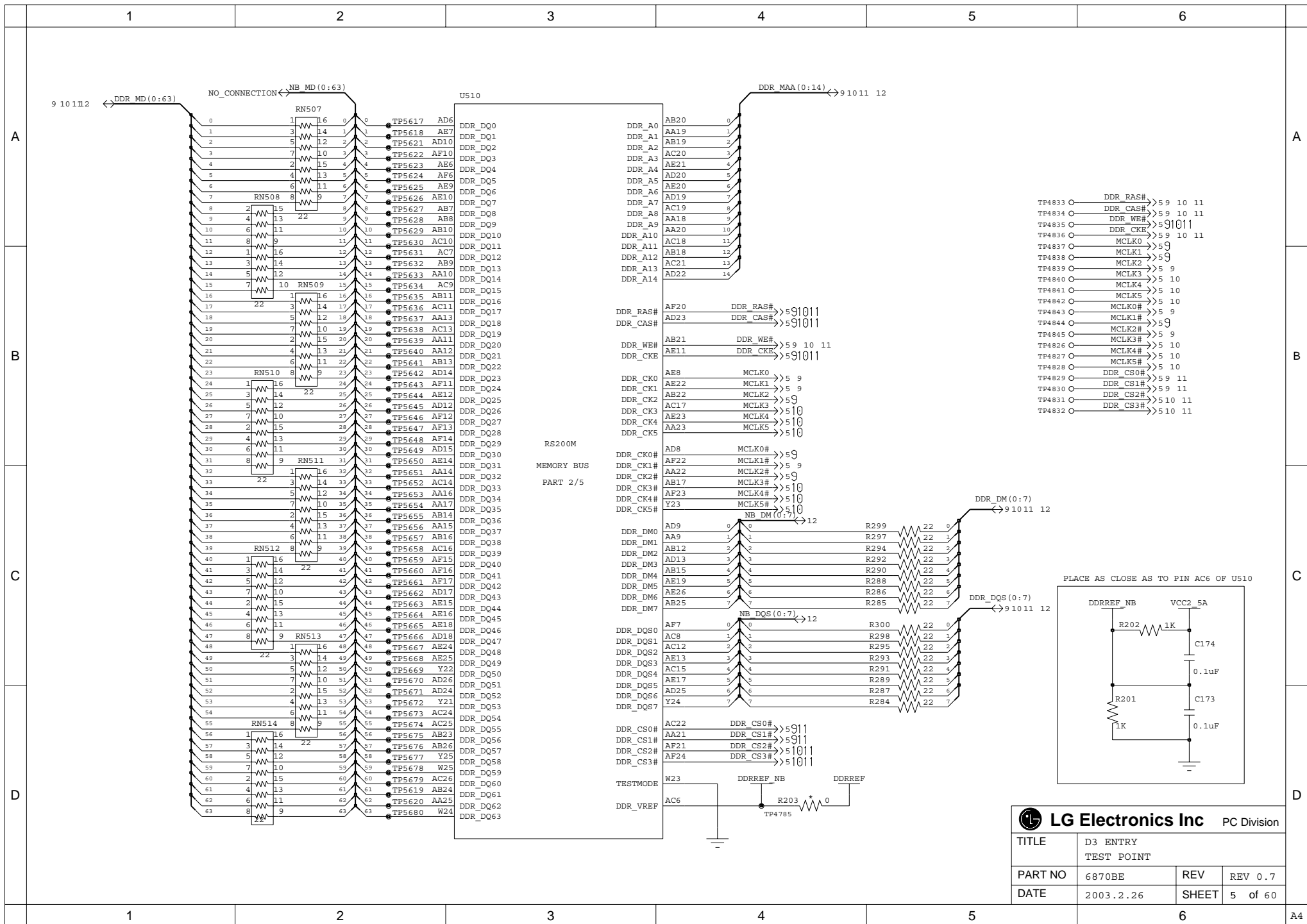

LG Electronics Inc PC Division			
TITLE	D3 ENTRY TEST POINT		
PART NO	6870BE	REV	REV 0.7
DATE	2003.2.26	SHEET	5 of 60

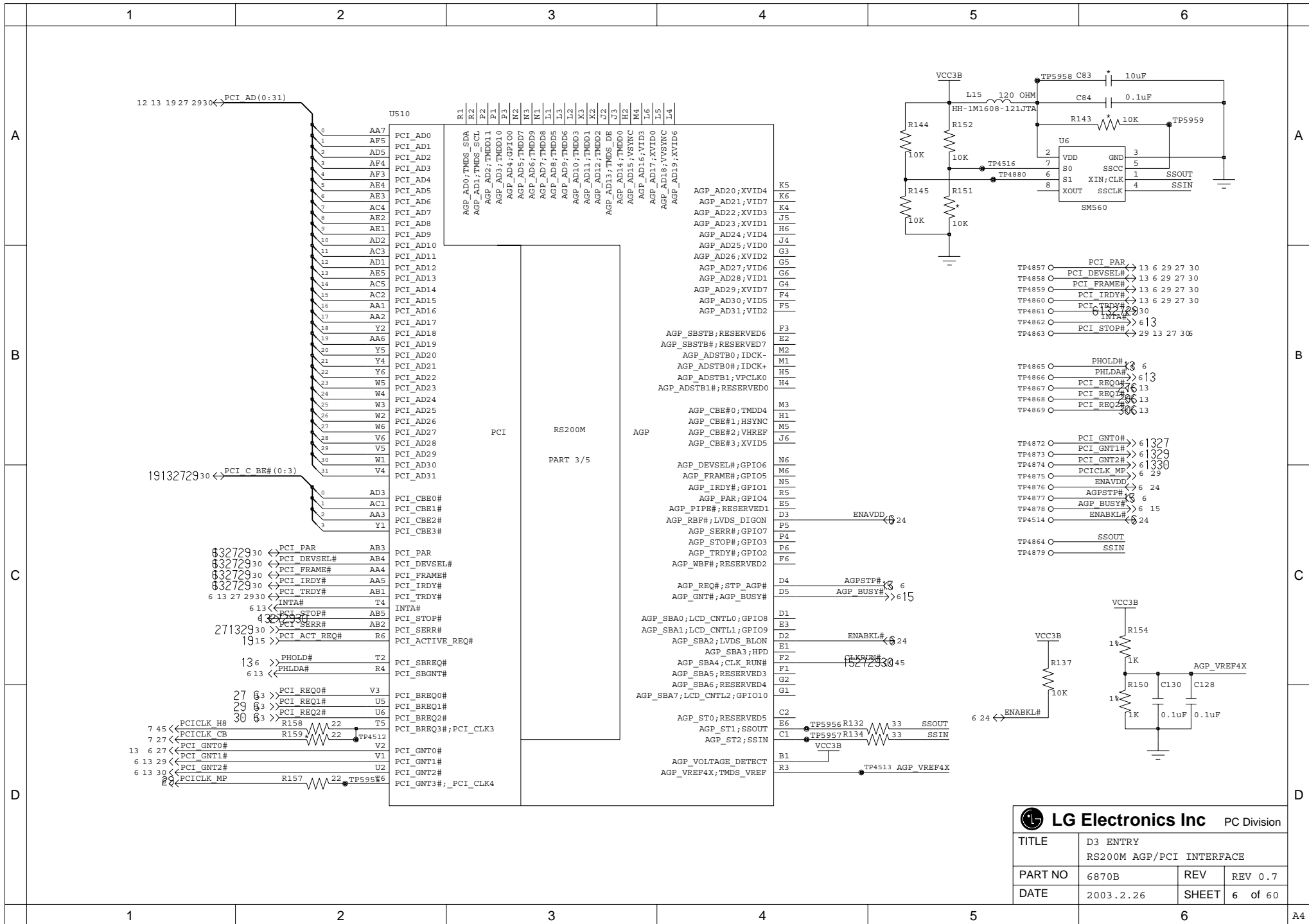

LG Electronics Inc PC Division

TITLE	D3 ENTRY RS200M AGP/PCI INTERFACE		
PART NO	6870B	REV	REV 0.7
DATE	2003.2.26	SHEET	6 of 60

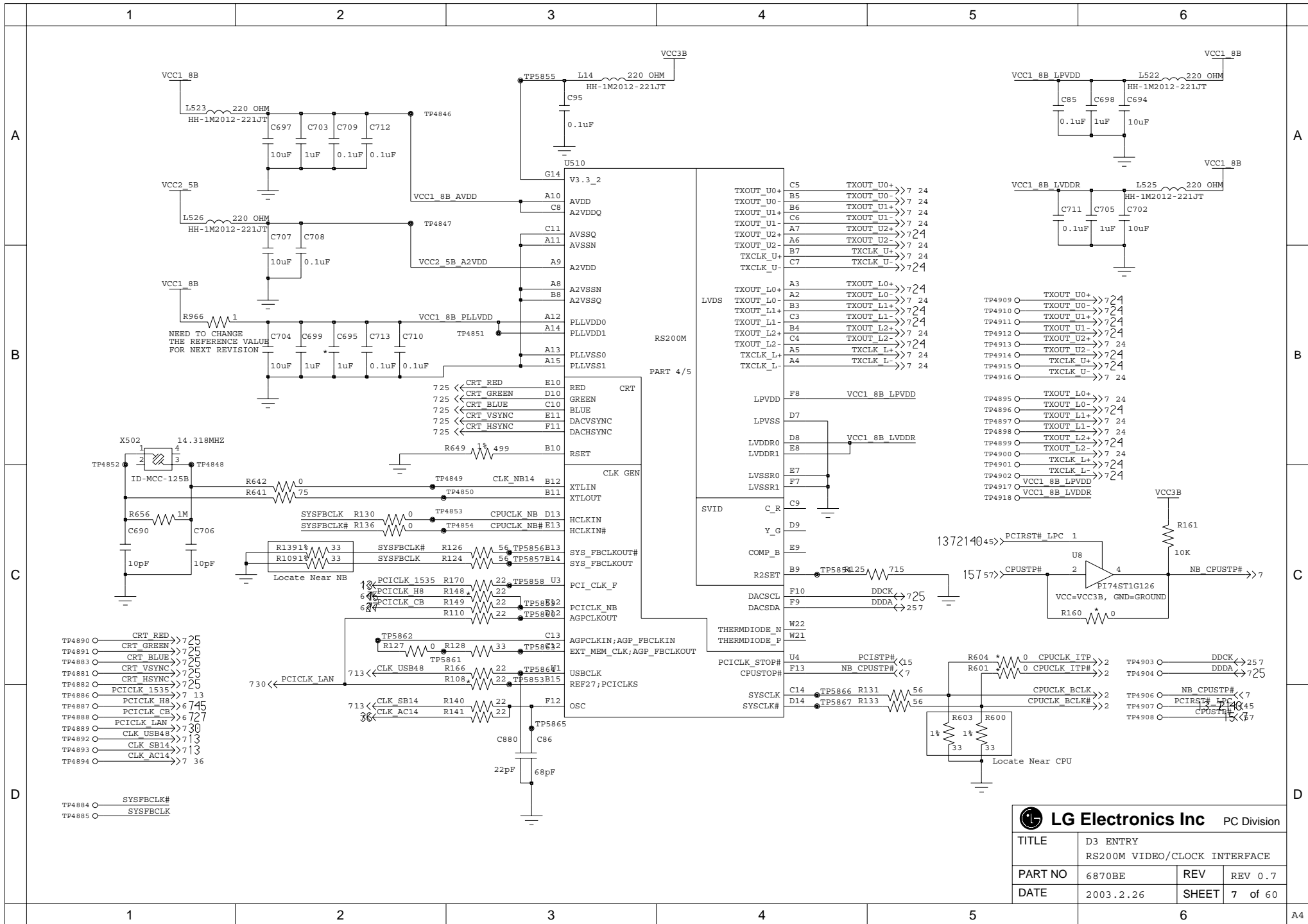

LG Electronics Inc PC Division			
TITLE	D3 ENTRY RS200M VIDEO/CLOCK INTERFACE		
PART NO	6870BE	REV	REV 0.7
DATE	2003.2.26	SHEET	7 of 60

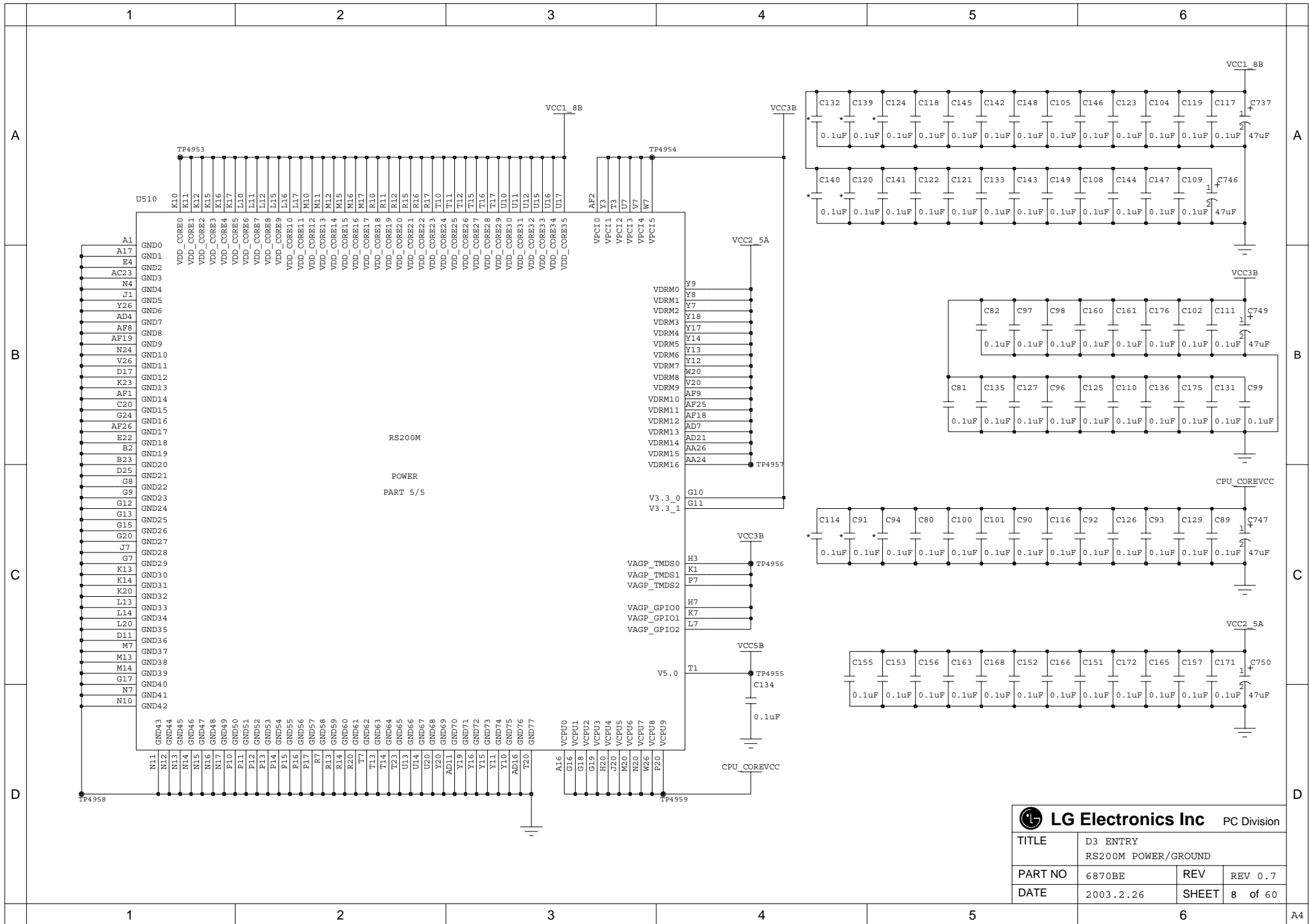

LG Electronics Inc PC Division			
TITLE D3 ENTRY RS200M POWER/GROUND			
PART NO	6870BE	REV	REV 0.7
DATE	2003.2.26	SHEET	8 of 60

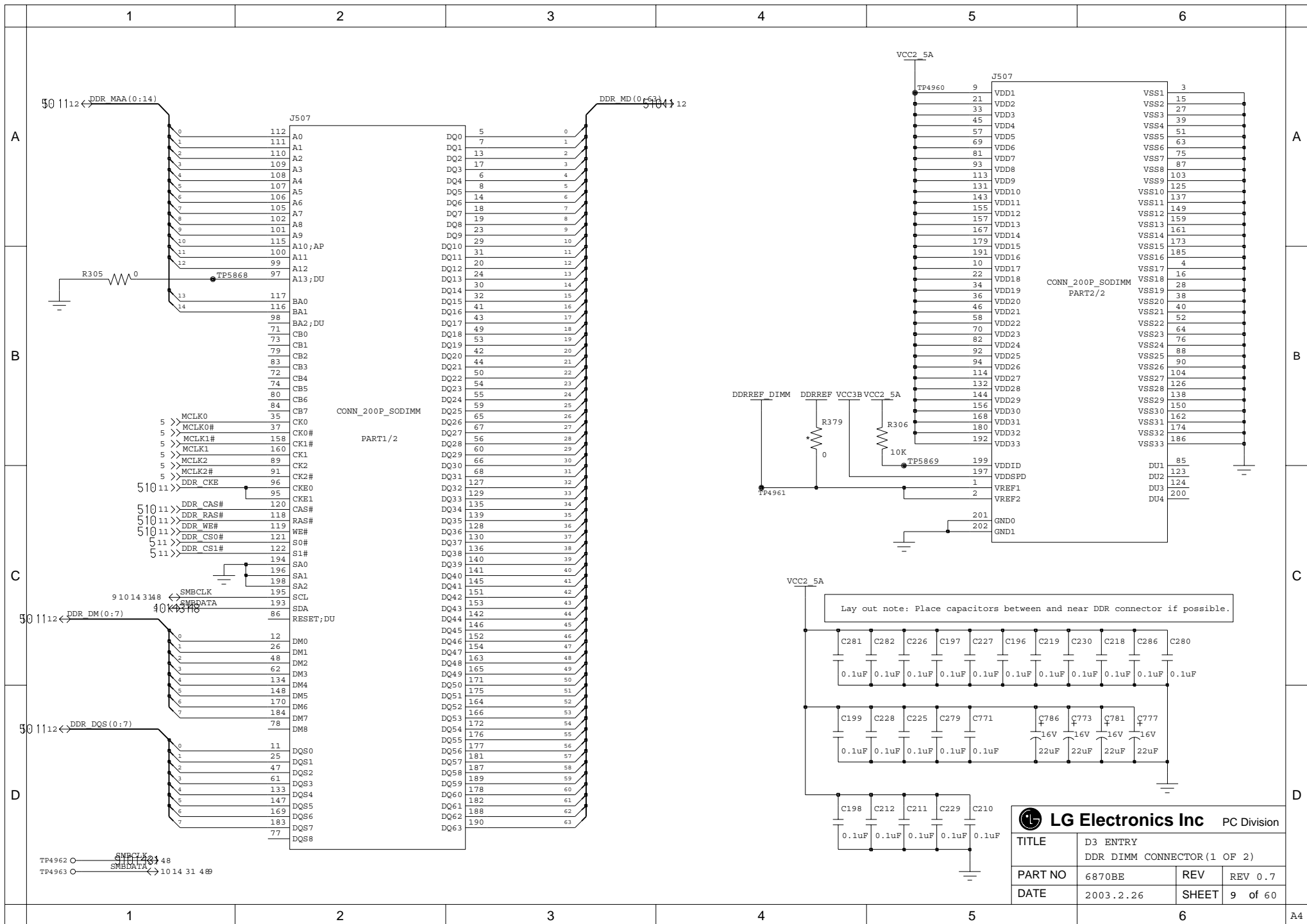

LG Electronics Inc PC Division			
TITLE	D3 ENTRY DDR DIMM CONNECTOR (1 OF 2)		
PART NO	6870BE	REV	REV 0.7
DATE	2003.2.26	SHEET	9 of 60

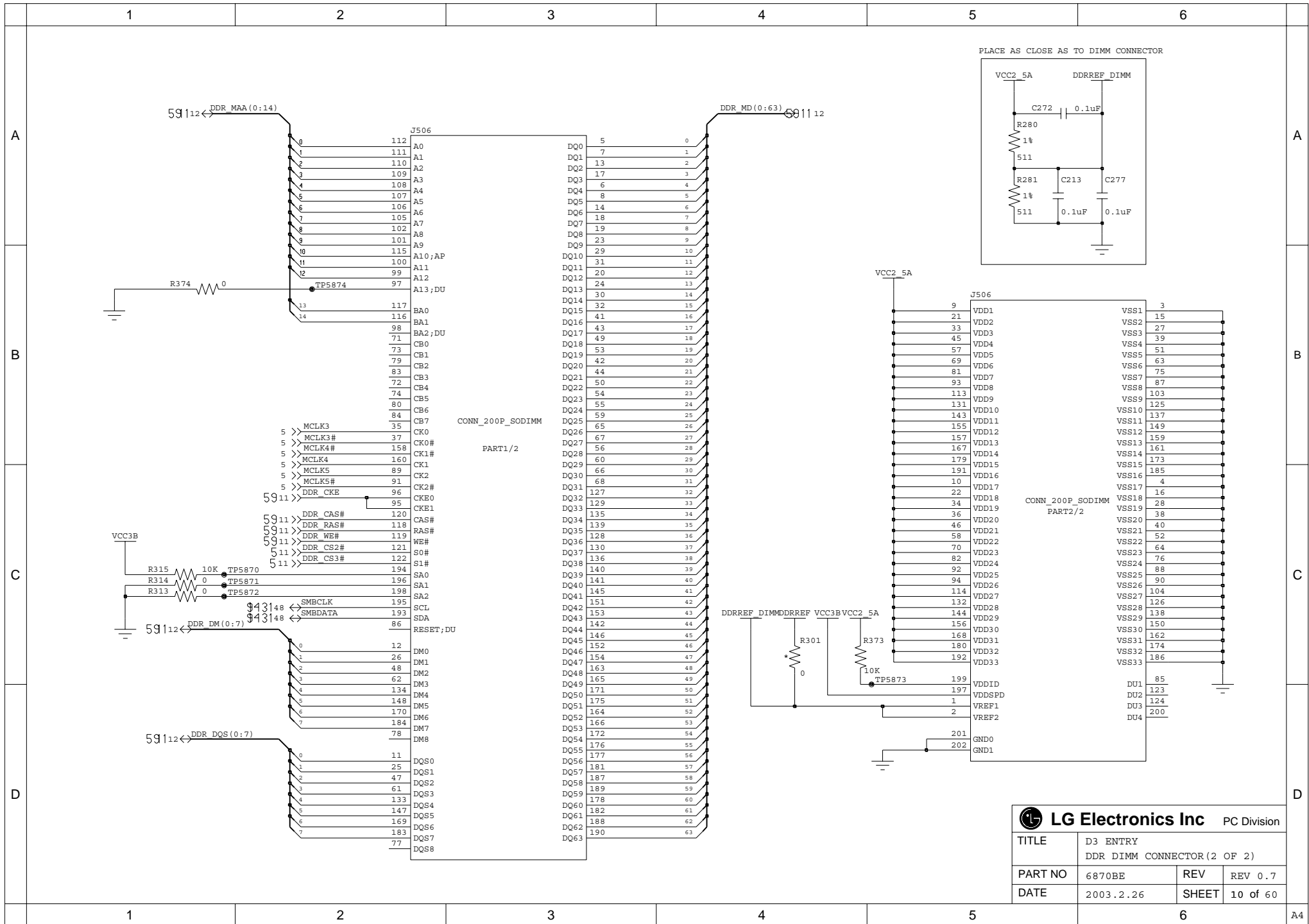

PLACE AS CLOSE AS TO DIMM CONNECTOR

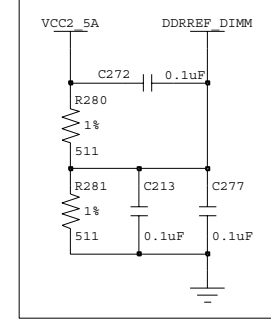

LG Electronics Inc PC Division			
TITLE	D3 ENTRY DDR DIMM CONNECTOR (2 OF 2)		
PART NO	6870BE	REV	REV 0.7
DATE	2003.2.26	SHEET	10 of 60

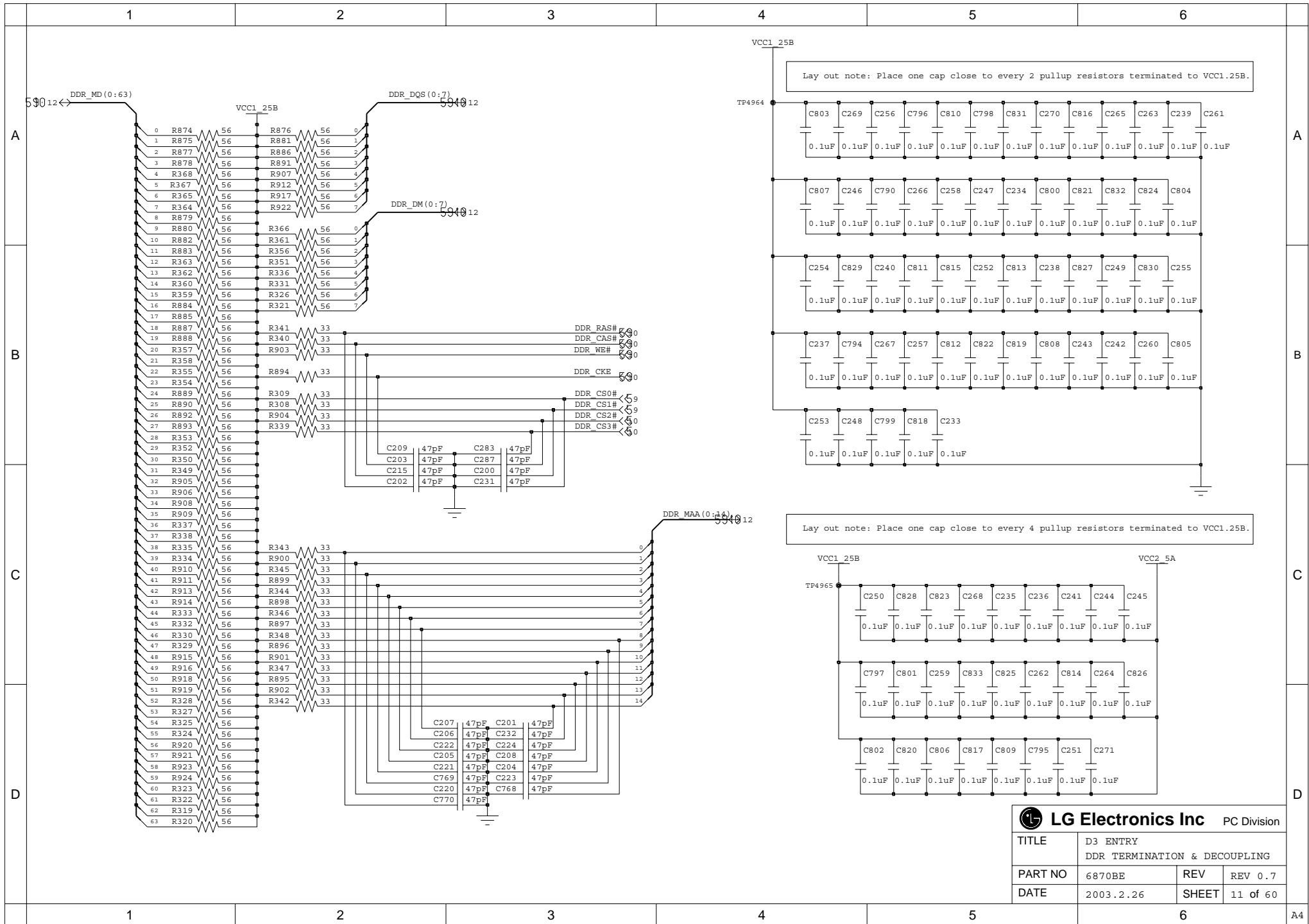

LG Electronics Inc PC Division

TITLE	D3 ENTRY DDR TERMINATION & DECOUPLING		
PART NO	6870BE	REV	REV 0.7
DATE	2003.2.26	SHEET	11 of 60

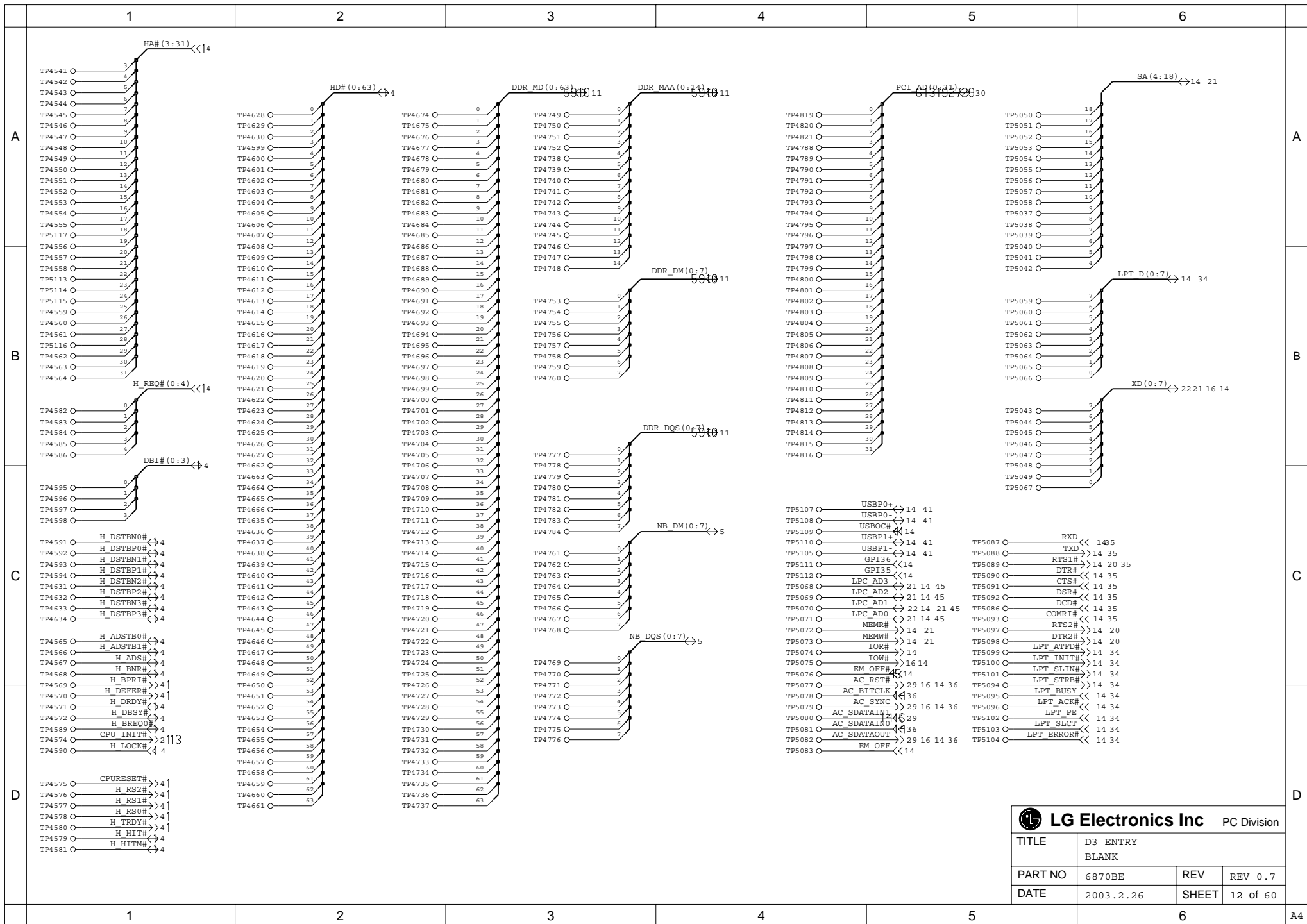

LG Electronics Inc PC Division			
TITLE	D3 ENTRY BLANK		
PART NO	6870BE	REV	REV 0.7
DATE	2003.2.26	SHEET	12 of 60

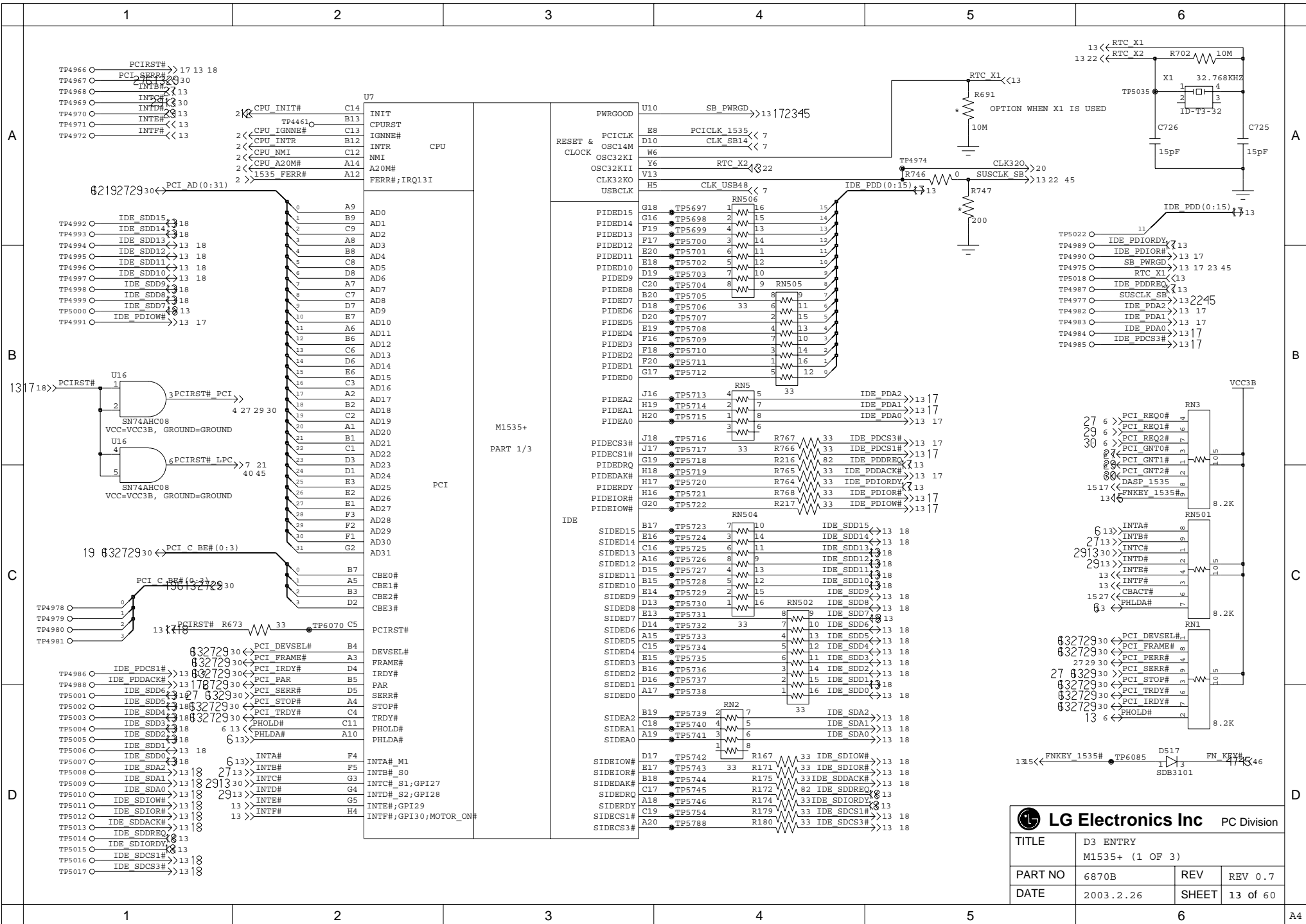

LG Electronics Inc PC Division			
TITLE	D3 ENTRY		
	M1535+ (1 OF 3)		
PART NO	6870B	REV	REV 0.7
DATE	2003.2.26	SHEET	13 OF 60

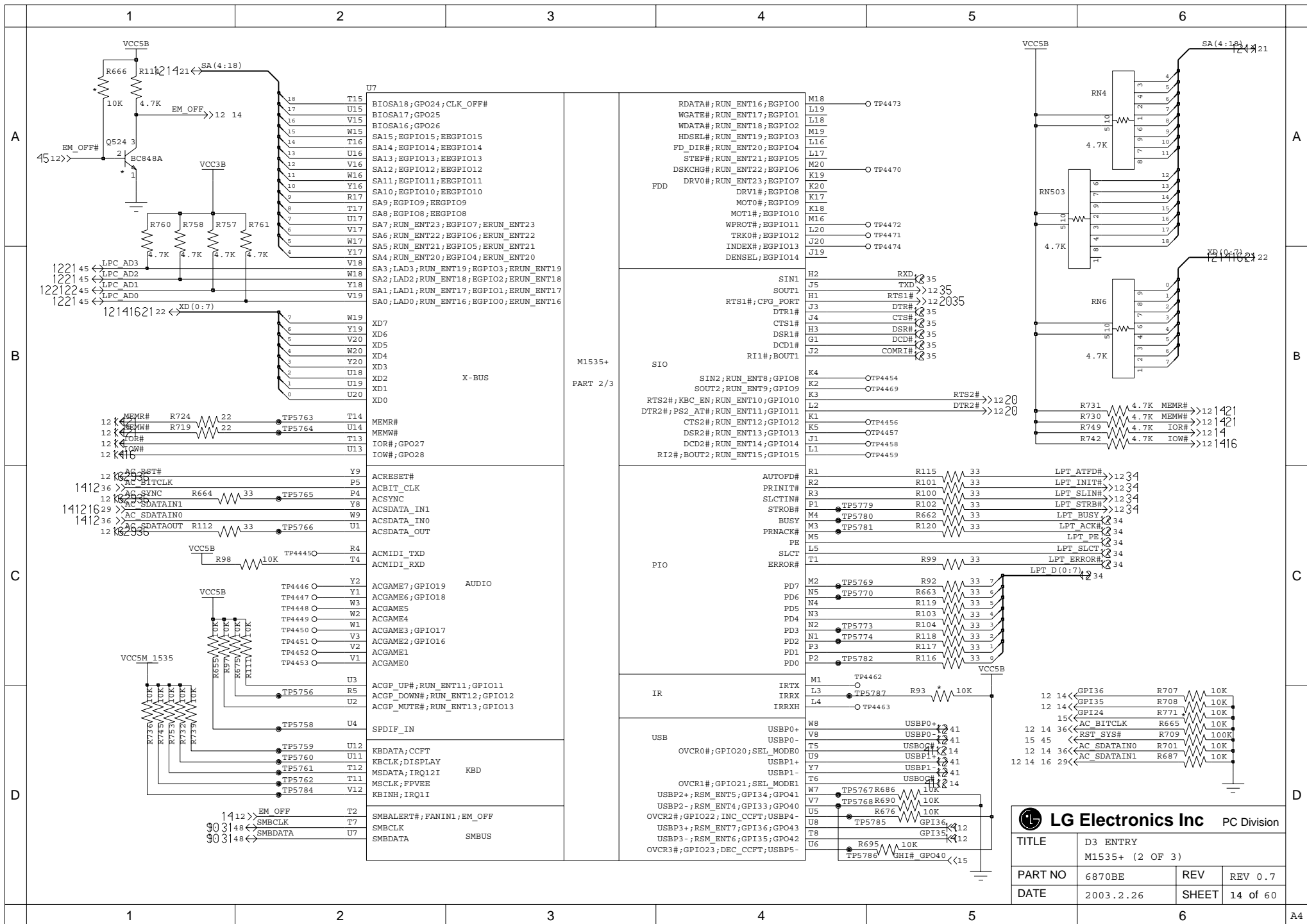

LG Electronics Inc PC Division			
TITLE	D3 ENTRY		
	M1535+ (2 OF 3)		
PART NO	6870BE	REV	REV 0.7
DATE	2003.2.26	SHEET	14 of 60

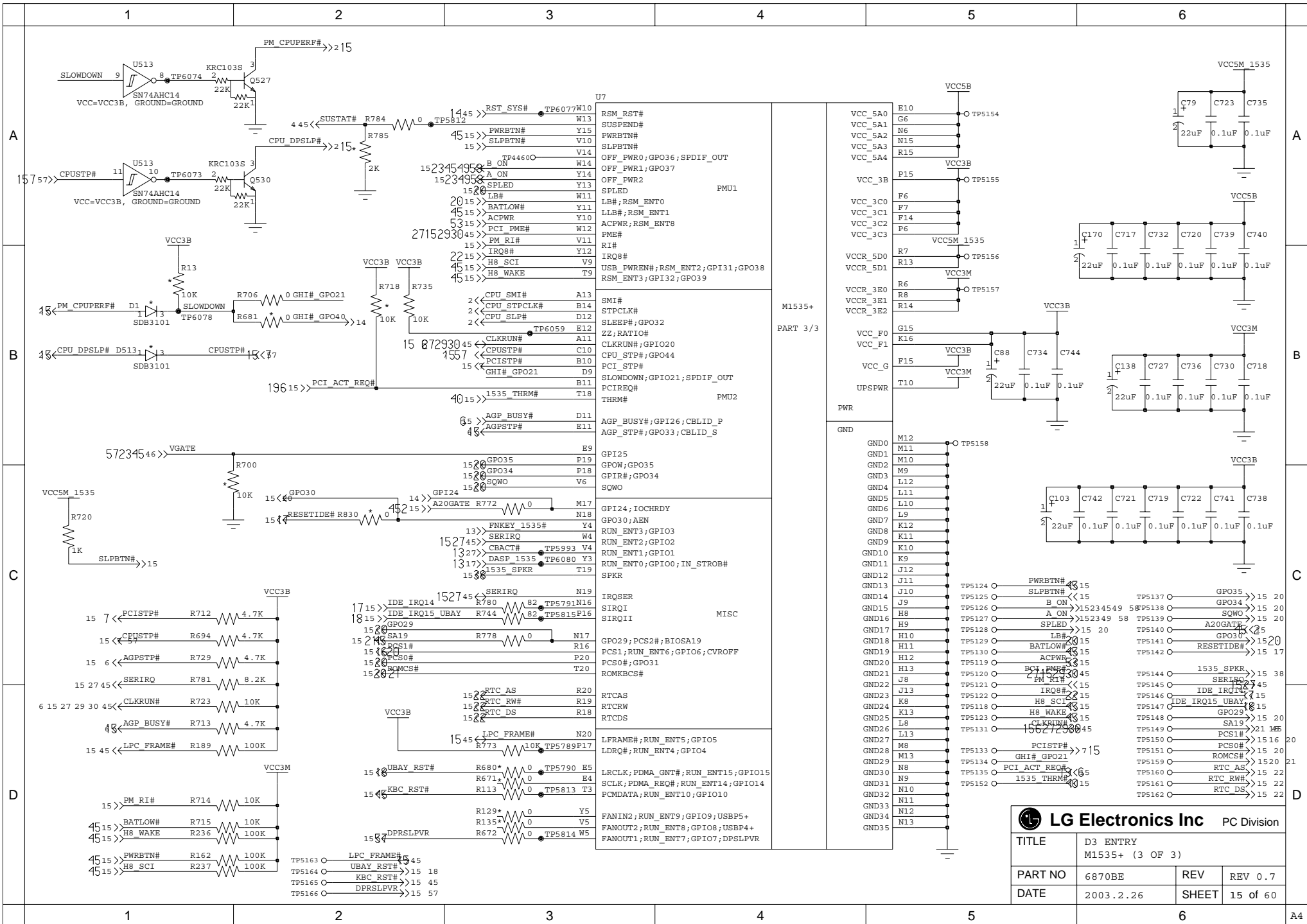

LG Electronics Inc PC Division

TITLE	D3 ENTRY M1535+ (3 OF 3)		
PART NO	6870BE	REV	REV 0.7
DATE	2003.2.26	SHEET	15 of 60

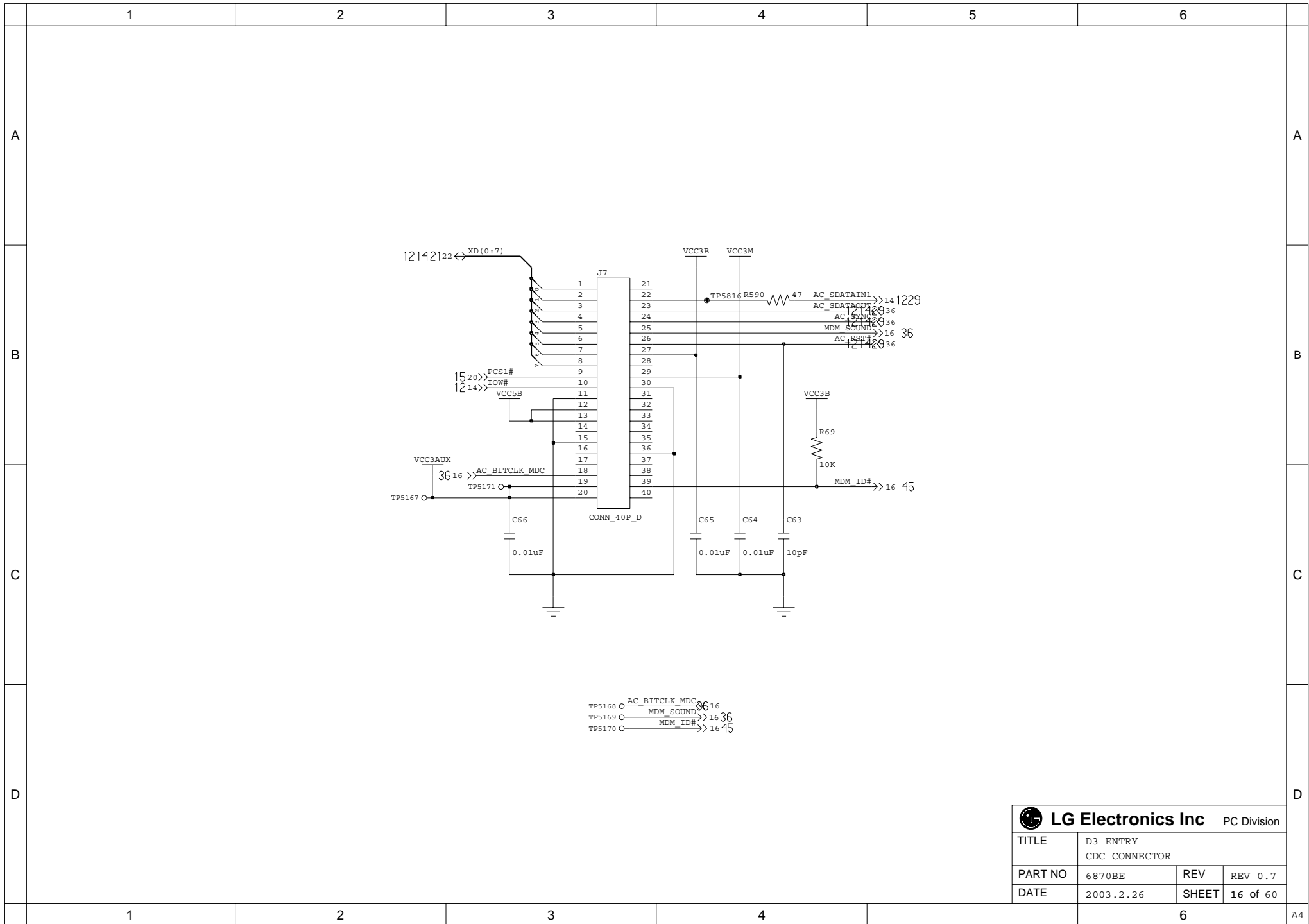

LG Electronics Inc PC Division			
TITLE	D3 ENTRY CDC CONNECTOR		
PART NO	6870BE	REV	REV 0.7
DATE	2003.2.26	SHEET	16 of 60

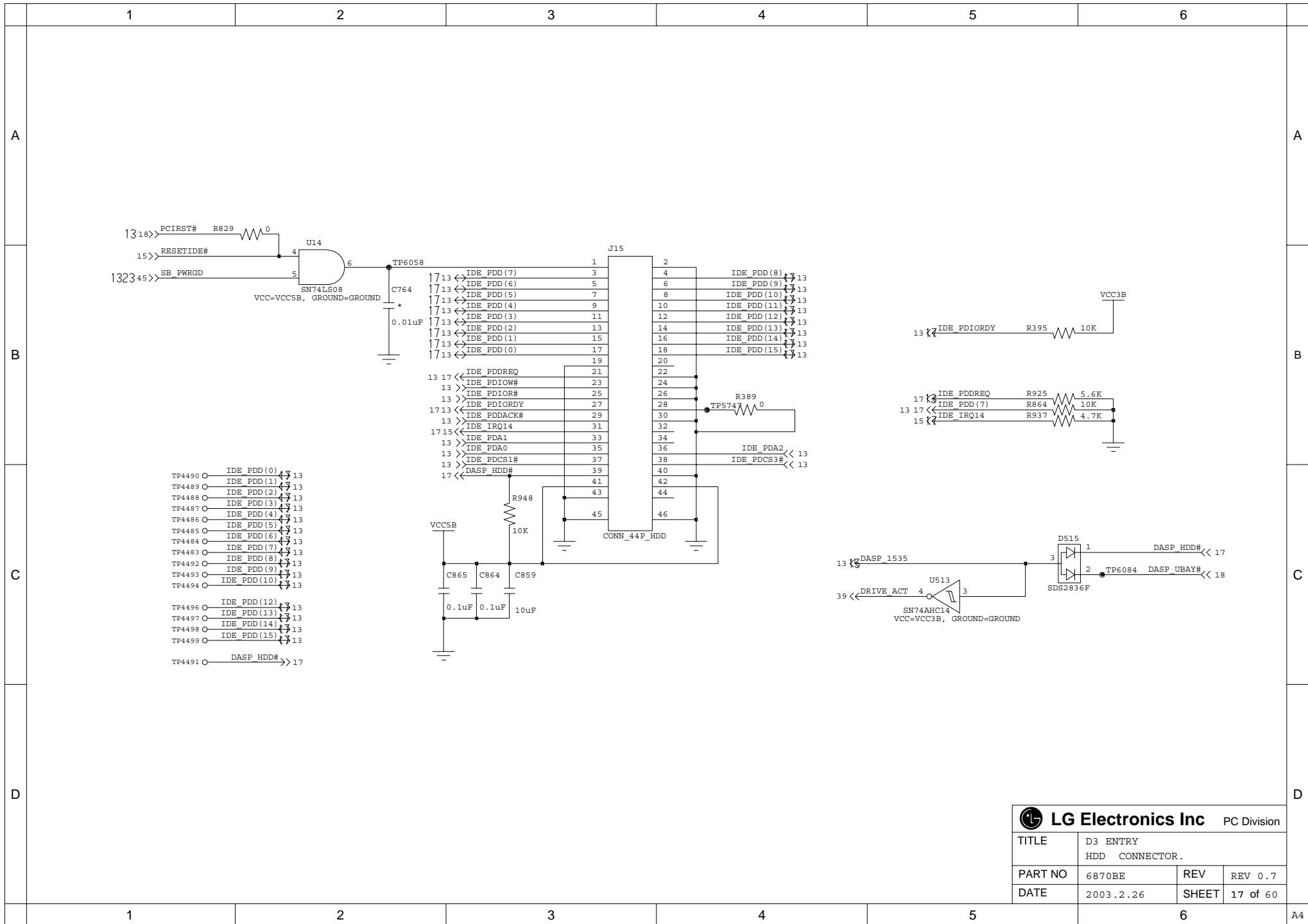

LG Electronics Inc PC Division

TITLE	D3 ENTRY HDD CONNECTOR.		
PART NO	6870BE	REV	REV 0.7
DATE	2003.2.26	SHEET	17 of 60

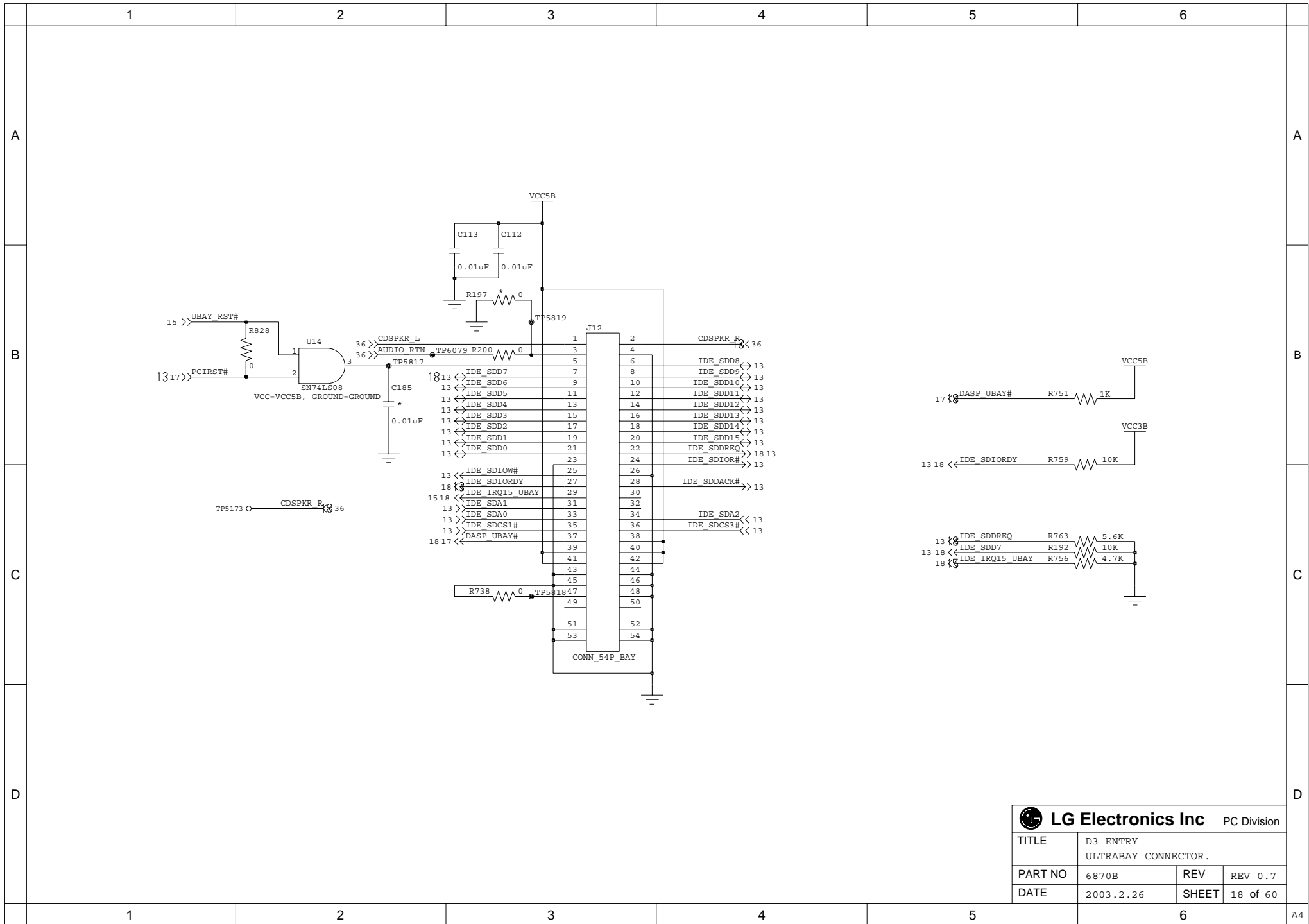

LG Electronics Inc PC Division			
TITLE		D3 ENTRY ULTRABAY CONNECTOR.	
PART NO	6870B	REV	REV 0.7
DATE	2003.2.26	SHEET	18 of 60

RS200M Strapping Options

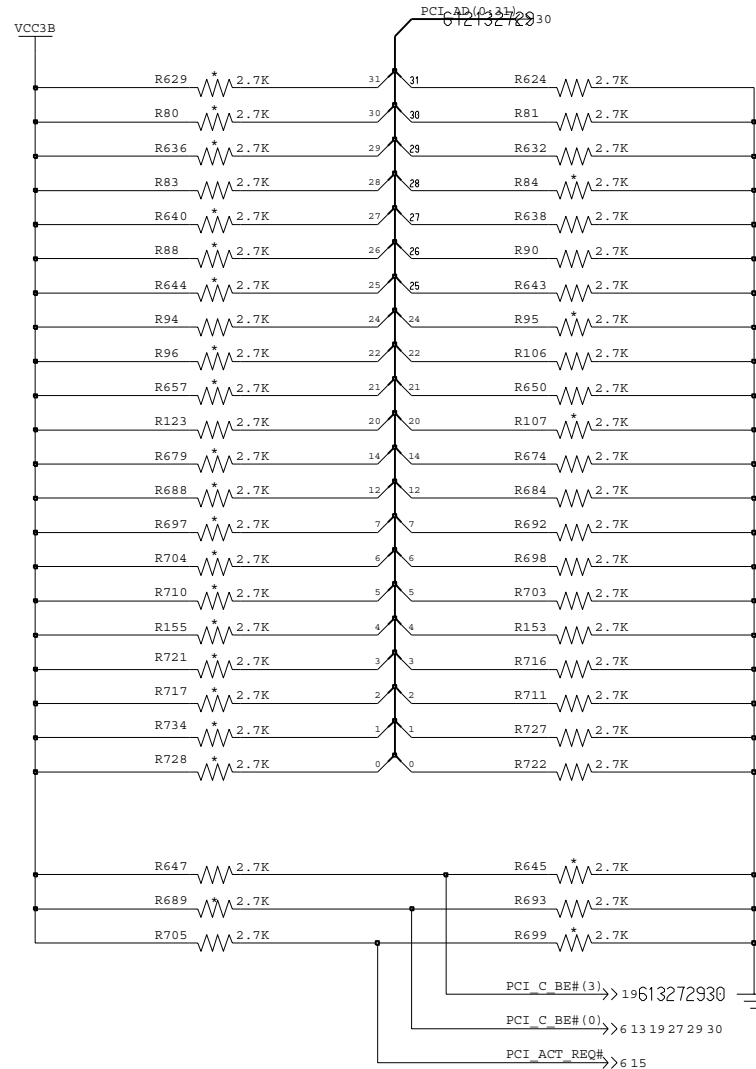

AD(31:30) FSB Speed	
00	100 MHz
01	133 MHz
10	166 MHz
11	66 MHz

AD(31:30) FSB Clock Speed

- AD29 : Strap Configuration
1: Reduced Set / 0: Full Set
- AD28 : Enable Spread Spectrum
1: Enable SS / 0: Disable SS
- AD27 : Disable MCERR# Observations
1: Disable / 0: Enable
- AD26 : Disable Bus Parking
1: Disable / 0: Enable
- AD25 : Disable BINIT# Observations
1: Disable / 0: Enable
- AD24 : Enable IOQ Pipelining
1: IOQ=12 / 0: IOQ=1
- AD22 : REF27 Function
1: 27MHz REF Input / 0: PCICLK5 Output
- AD21 : Clock Bypass
1: Test Mode / 0: Normal Mode
- AD20 : PCI Clock Expansion (REQ3# & GNT3#)
1: PCICLK3 & PCICLK4 / 0: REQ & GNT Pair
- AD14 : P4 Voltage Detection
1: 1.7V DT CPU / 0: 1.2V NT CPU
- AD12 : Flat Panel ID4
FP_ID4
- AD11 : Flat Panel ID3
FP_ID3
- AD10 : Flat Panel ID2
FP_ID2
- AD5 : Flat Panel ID1
FP_ID1
- AD4 : Flat Panel ID0
FP_ID0
- AD3 : A-Link Enable
1: A-Link / 0: PCI-33
- AD2 : Auto Calibration Enable
1: Disable / 0: Enable
- AD1 : CPU Reset Forced to Be Shortened
1: Test Mode / 0: Normal Mode
- AD0 : Default CFG for GC Enable bit & AGPCLKOUT
1: '0' & 66MHz AGP / 0: '0' & 33MHz PCI

FP_ID(0:4)

- PCI_CBE3# : Production Test
1: Normal / 0: Production Test
- PCI_CBE0# : Reserved
Set to 0 (only for A11,A12, A13)
- PCI_ACT_REQ# : Internal Clock Generator Enable
1: Int. Clock / 0: Ext. Clock

LG Electronics Inc PC Division			
TITLE	D3 ENTRY SYSTEM CONFIGURATION		
PART NO	6870B	REV	REV 0.7
DATE	2003.2.26	SHEET	19 of 60

A

B

C

D

A

B

C

D

1

2

3

4

5

6

1

2

3

4

5

6

A4

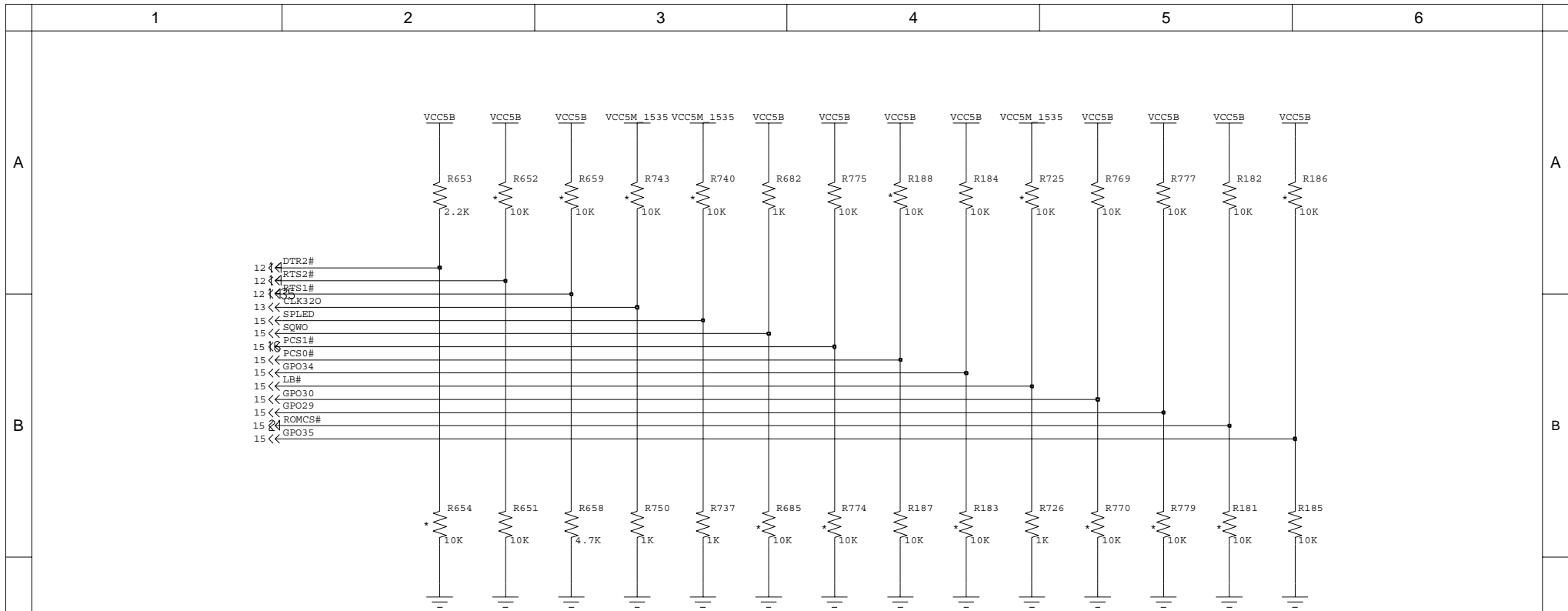

	DTR2#	RTS2#	RTS1#	CLK320	SPLED	SQWO	PCS1#	PCS0#	GPO34	LB#	GPO30 GPO29	ROMCS# GPO35
PULL HIGH	INTERNAL KEYBOARD PS2 MODE DEFAULT	ENABLE INTERNAL KEYBOARD DEFAULT	SIO BASE ADDRESS 0X3F0h	32K CLOCK TEST MODE ENABLE	AT POWER MODE	PENTIUM II MODE DEFAULT	GPI24 & GPO30 FUNCTIONS DEFAULT	DEISABLE 4Mb FLASH ROM MODE	CHIP TEST MODE DISABLE DEFAULT	ACTIVE HIGH TO POWER OFF	L,L-USB TEST MODE L,H -AUDIO/MODEM TEST MODE H,L-SUPER IO TEST MODE H,H-NORMAL OPERATION DEFAULT : H,H	FLASH ROM MODE SELECTION L,L-RESERVED L,H-ENABLE 8mb Flash ROM SIZE H,L-DISABLE ALL FUNC. IN THIS CONFIG. DEFAULT:H,L H,H-ENABLE LPC FLASH ROM
PULL LOW	INTERNAL KEYBOARD AT MODE	DISABLE INTERNAL KEYBOARD	SIO BASE ADDRESS 0X370h DEFAULT	32K CLOCK TEST MODE DISABLE DEFAULT	ATX POWER MODE DEFAULT	PENTIUM/K7 MODE	IOCHRDY & AEN FUNCTIONS	ENABLE 4Mb FLASH ROM MODE DEFAULT	CHIP TEST MODE ENABLE	ACTIVE LOW TO POWER OFF DEFAULT		

LG Electronics Inc PC Division

TITLE	D3 ENTRY M1535+ BOOT STRAPS		
PART NO	6870BE	REV	REV 0.7
DATE	2003.2.26	SHEET	20 of 60

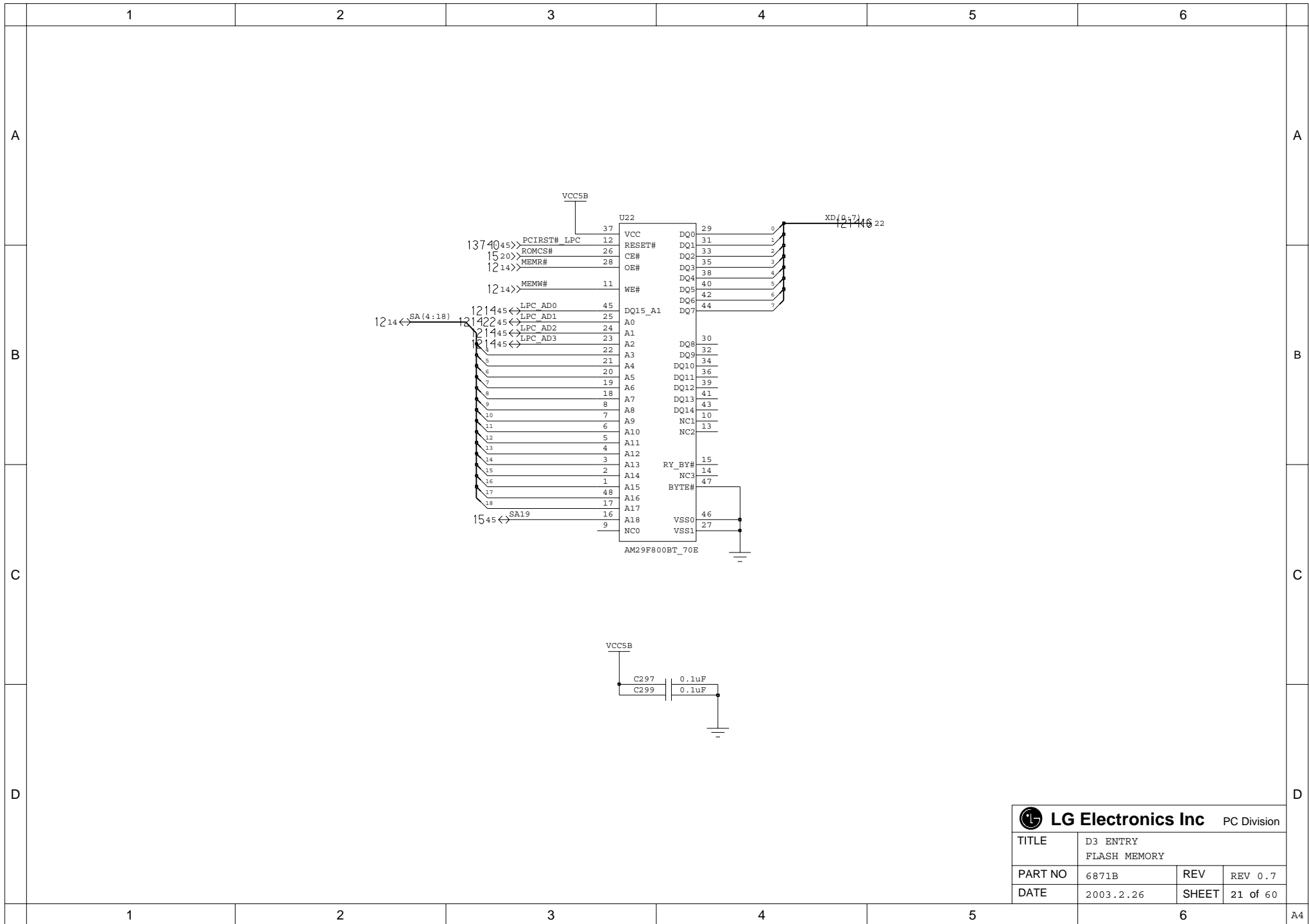

 LG Electronics Inc PC Division			
TITLE	D3 ENTRY FLASH MEMORY		
PART NO	6871B	REV	REV 0.7
DATE	2003.2.26	SHEET	21 of 60

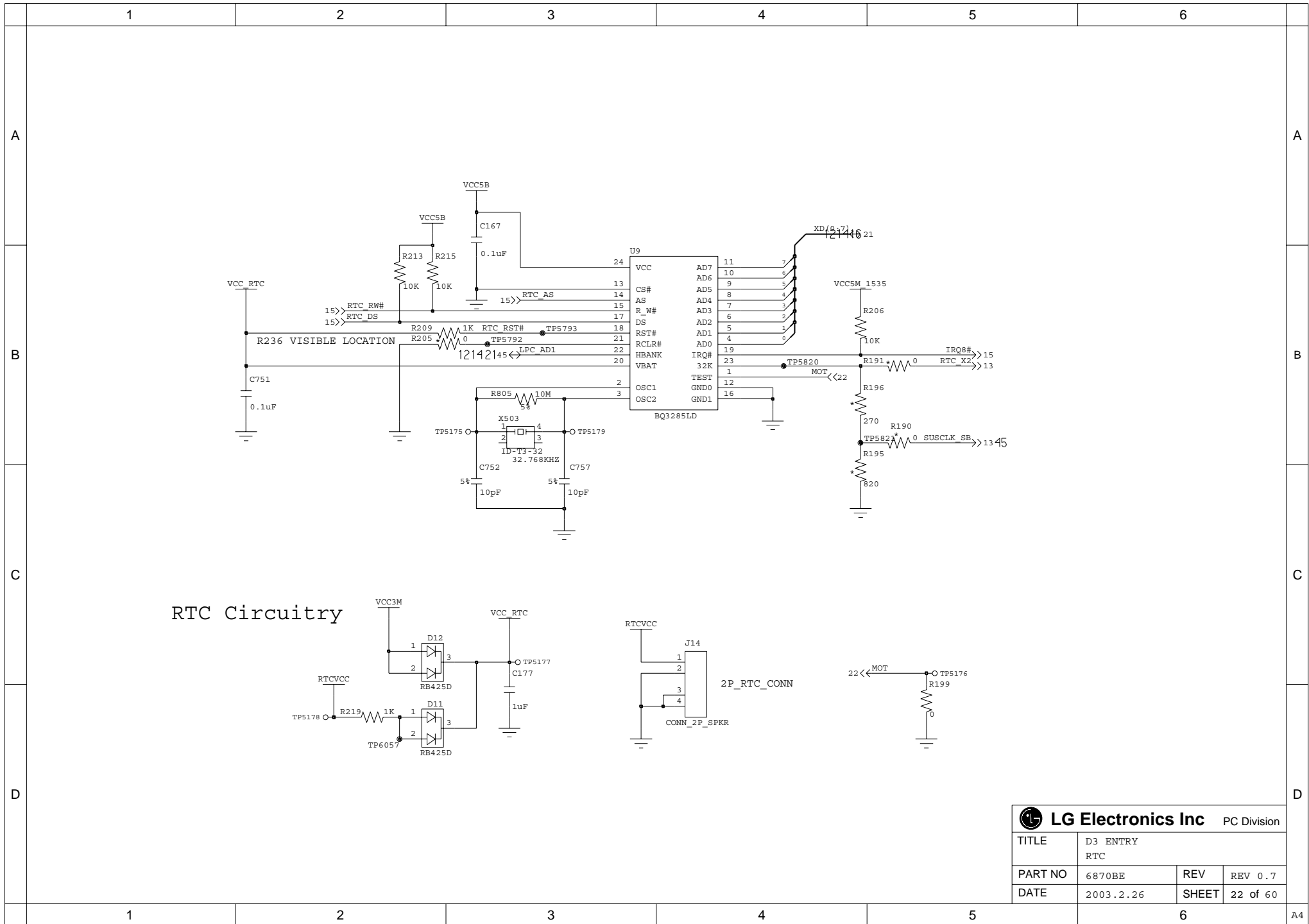

RTC Circuitry

LG Electronics Inc PC Division			
TITLE	D3 ENTRY RTC		
PART NO	6870BE	REV	REV 0.7
DATE	2003.2.26	SHEET	22 of 60

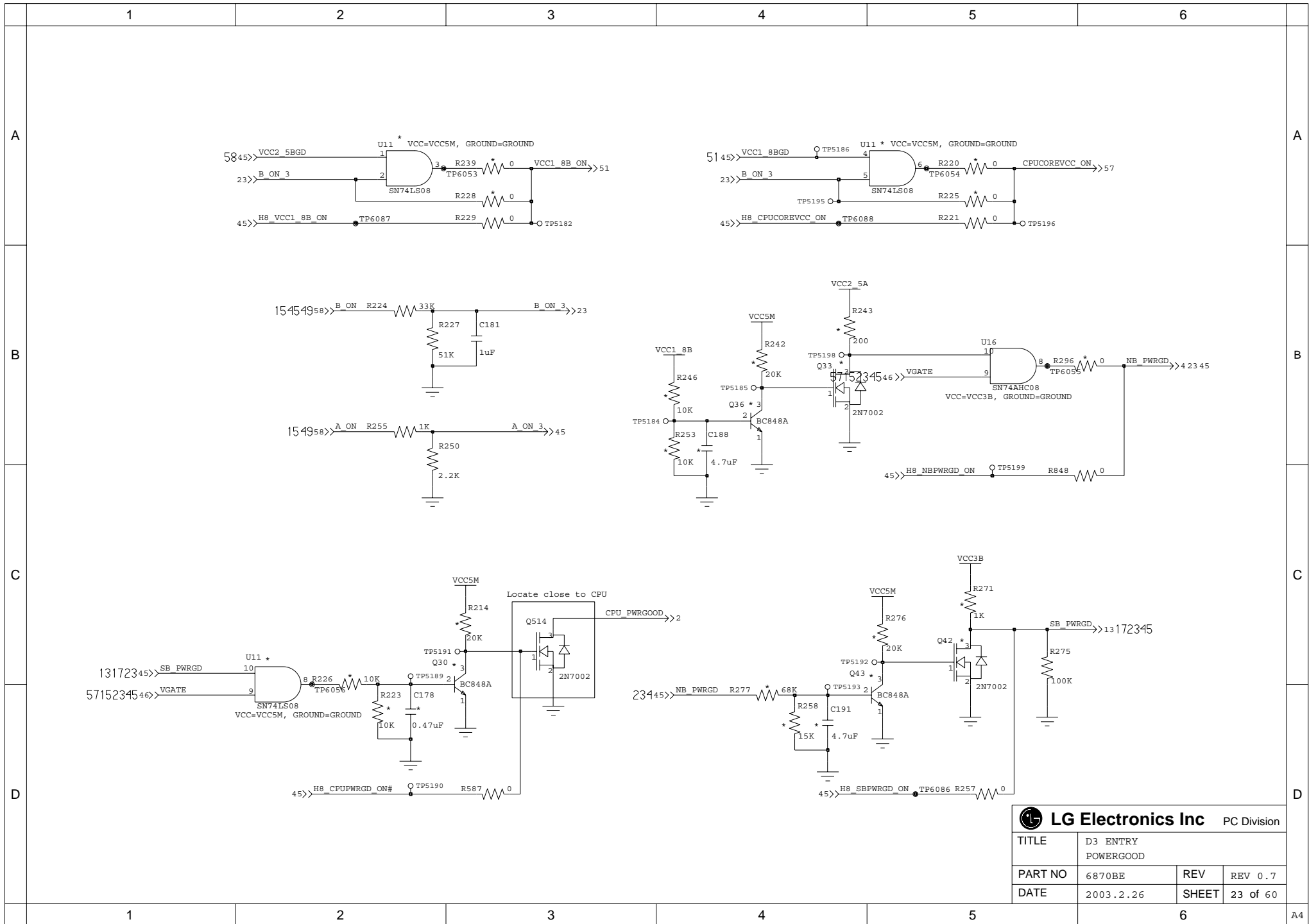

LG Electronics Inc PC Division			
TITLE	D3 ENTRY POWERGOOD		
PART NO	6870BE	REV	REV 0.7
DATE	2003.2.26	SHEET	23 of 60

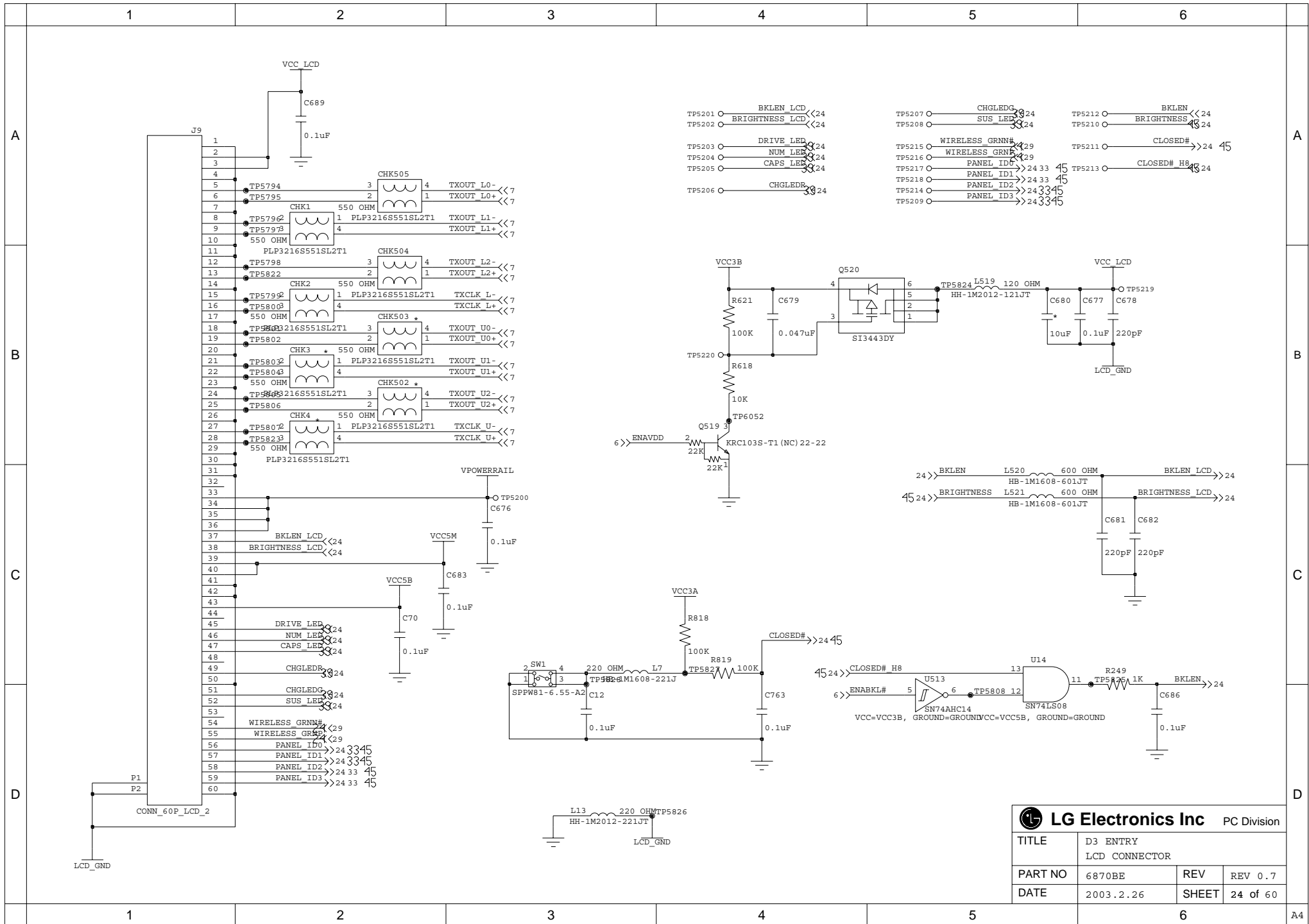

LG Electronics Inc PC Division			
TITLE		D3 ENTRY LCD CONNECTOR	
PART NO	6870BE	REV	REV 0.7
DATE	2003.2.26	SHEET	24 of 60

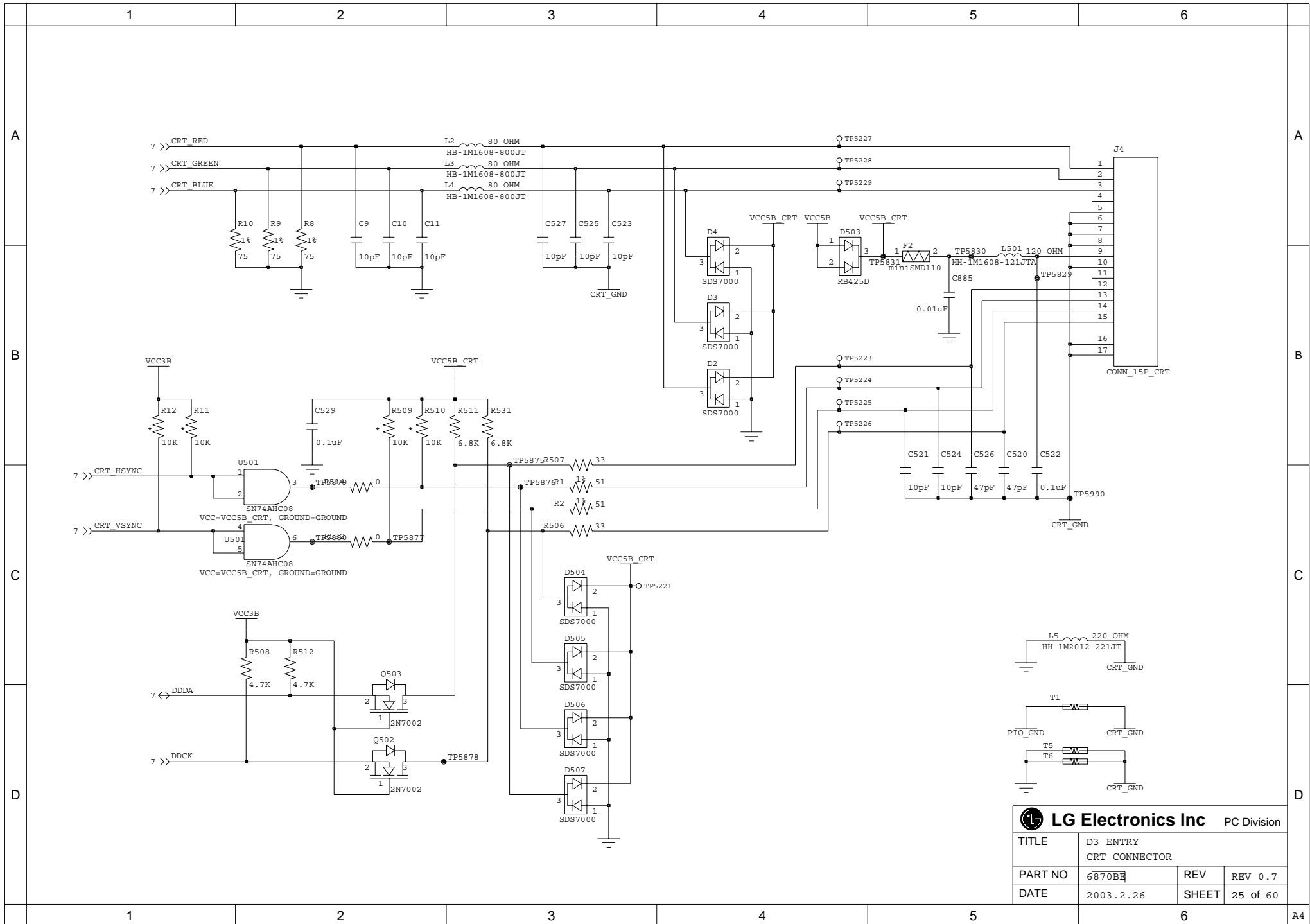

LG Electronics Inc PC Division

TITLE	D3 ENTRY CRT CONNECTOR		
PART NO	6870BE	REV	REV 0.7
DATE	2003.2.26	SHEET	25 of 60

	1	2	3	4	5	6	
A							A
B							B
C							C
D							D
	1	2	3	4	5	6	A4

 LG Electronics Inc PC Division			
TITLE	D3 ENTRY BLANK		
PART NO	6870BE	REV	REV 0.7
DATE	2003.2.26	SHEET	26 of 60

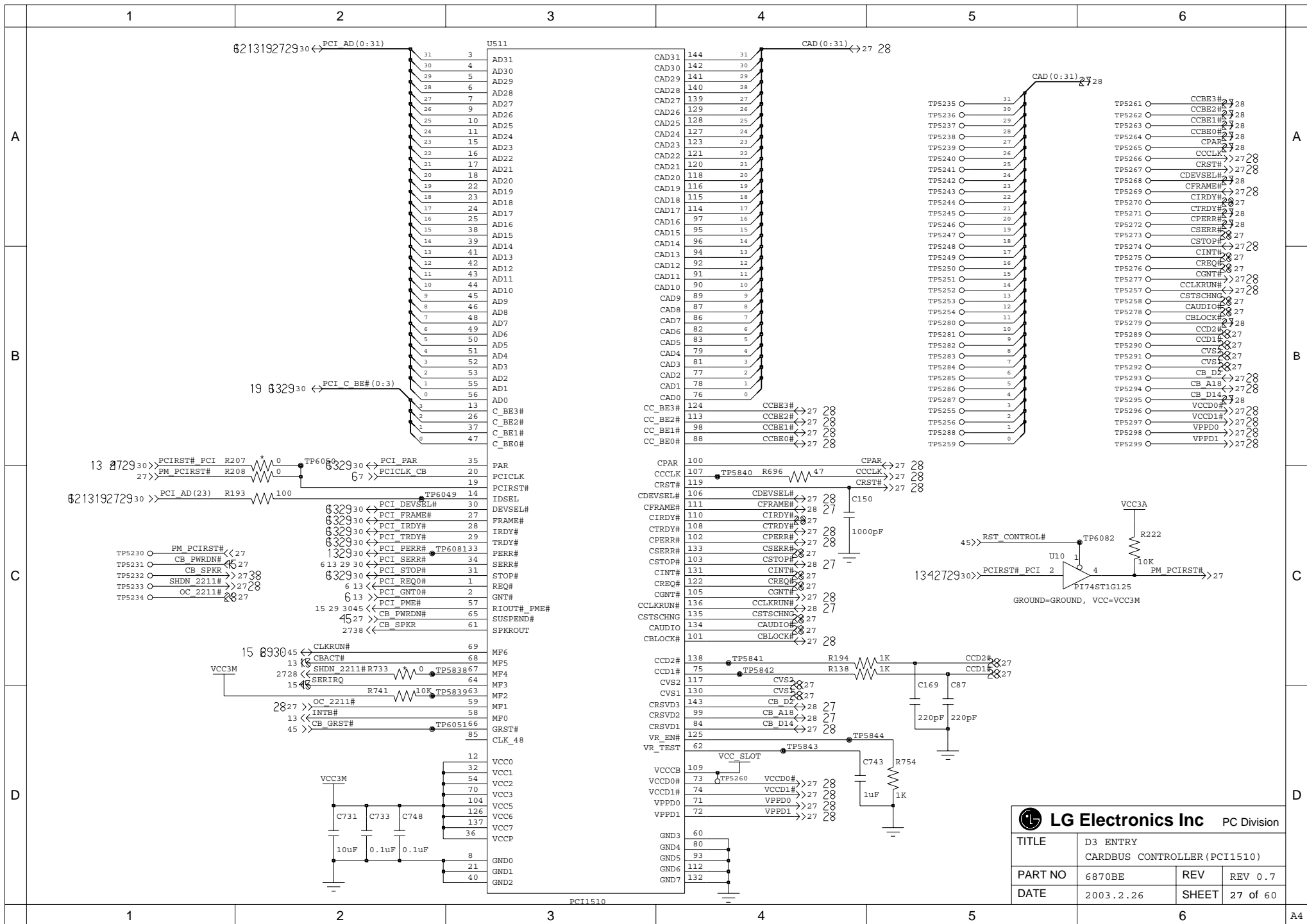

LG Electronics Inc PC Division			
TITLE	D3 ENTRY CARDBUS CONTROLLER (PCI1510)		
PART NO	6870BE	REV	REV 0.7
DATE	2003.2.26	SHEET	27 of 60

PCI1510

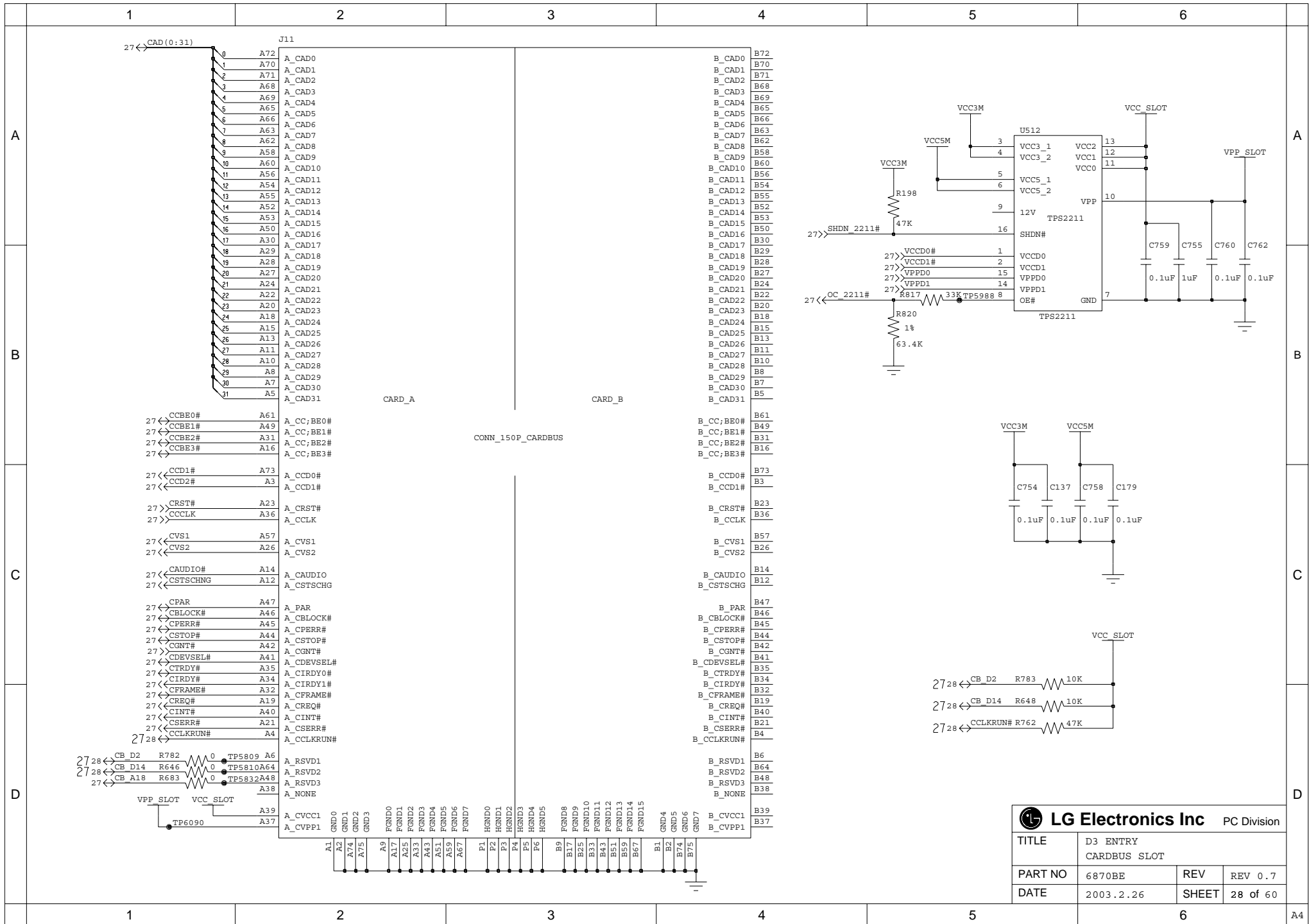

LG Electronics Inc PC Division			
TITLE	D3 ENTRY CARDBUS SLOT		
PART NO	6870BE	REV	REV 0.7
DATE	2003.2.26	SHEET	28 of 60

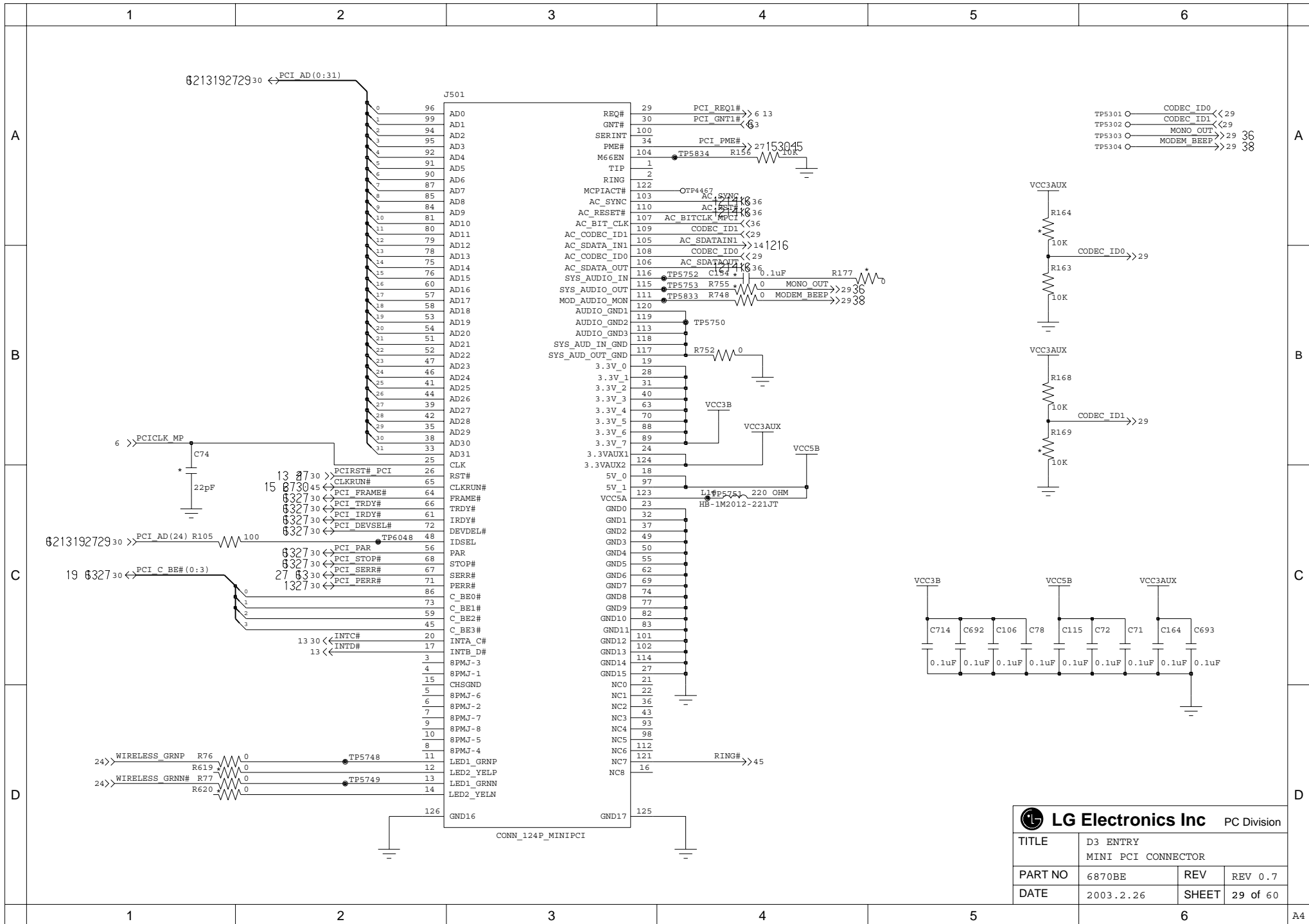

LG Electronics Inc PC Division			
TITLE	D3 ENTRY MINI PCI CONNECTOR		
PART NO	6870BE	REV	REV 0.7
DATE	2003.2.26	SHEET	29 of 60

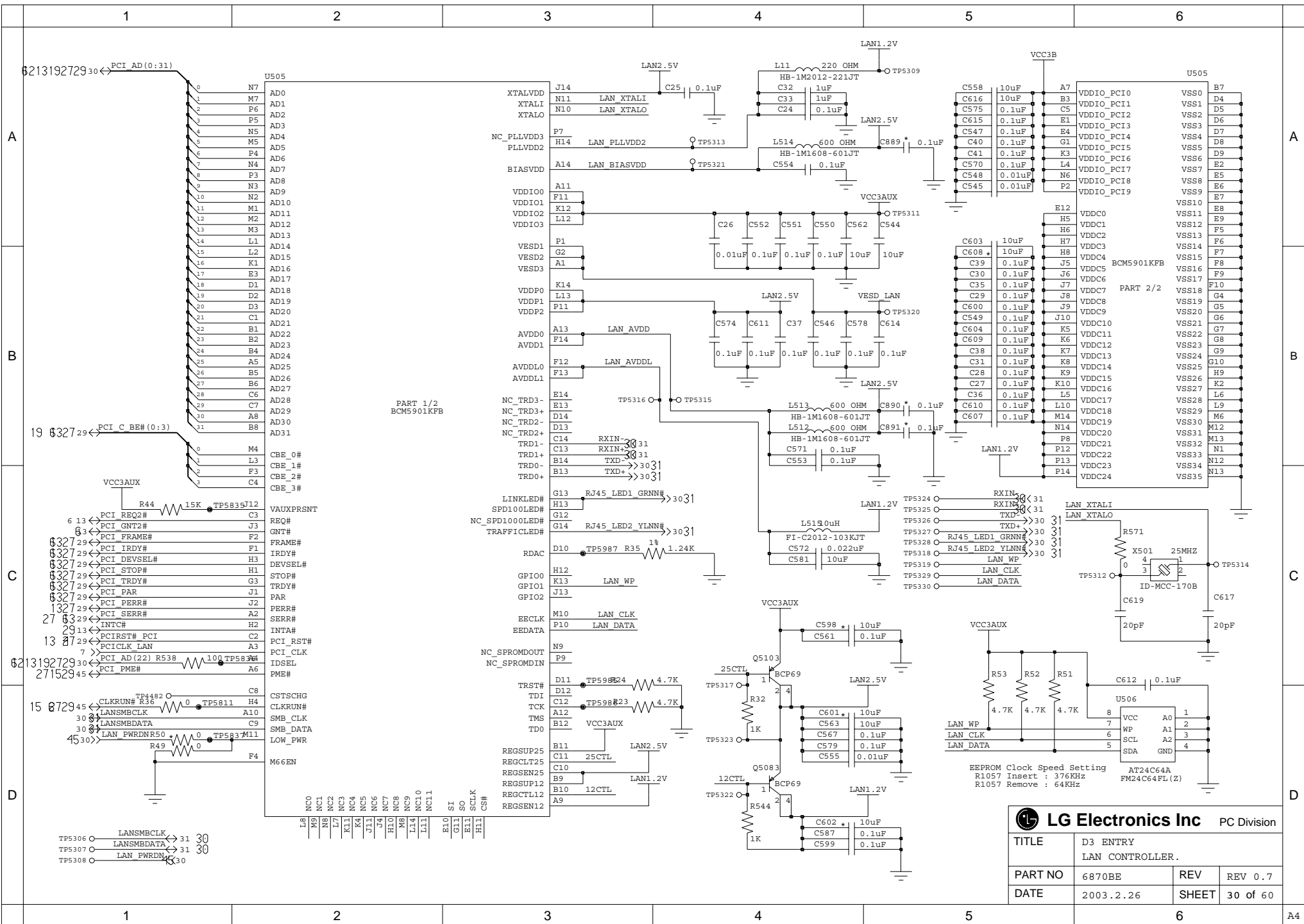

LG Electronics Inc PC Division

TITLE	D3 ENTRY LAN CONTROLLER.		
PART NO	6870BE	REV	REV 0.7
DATE	2003.2.26	SHEET	30 of 60

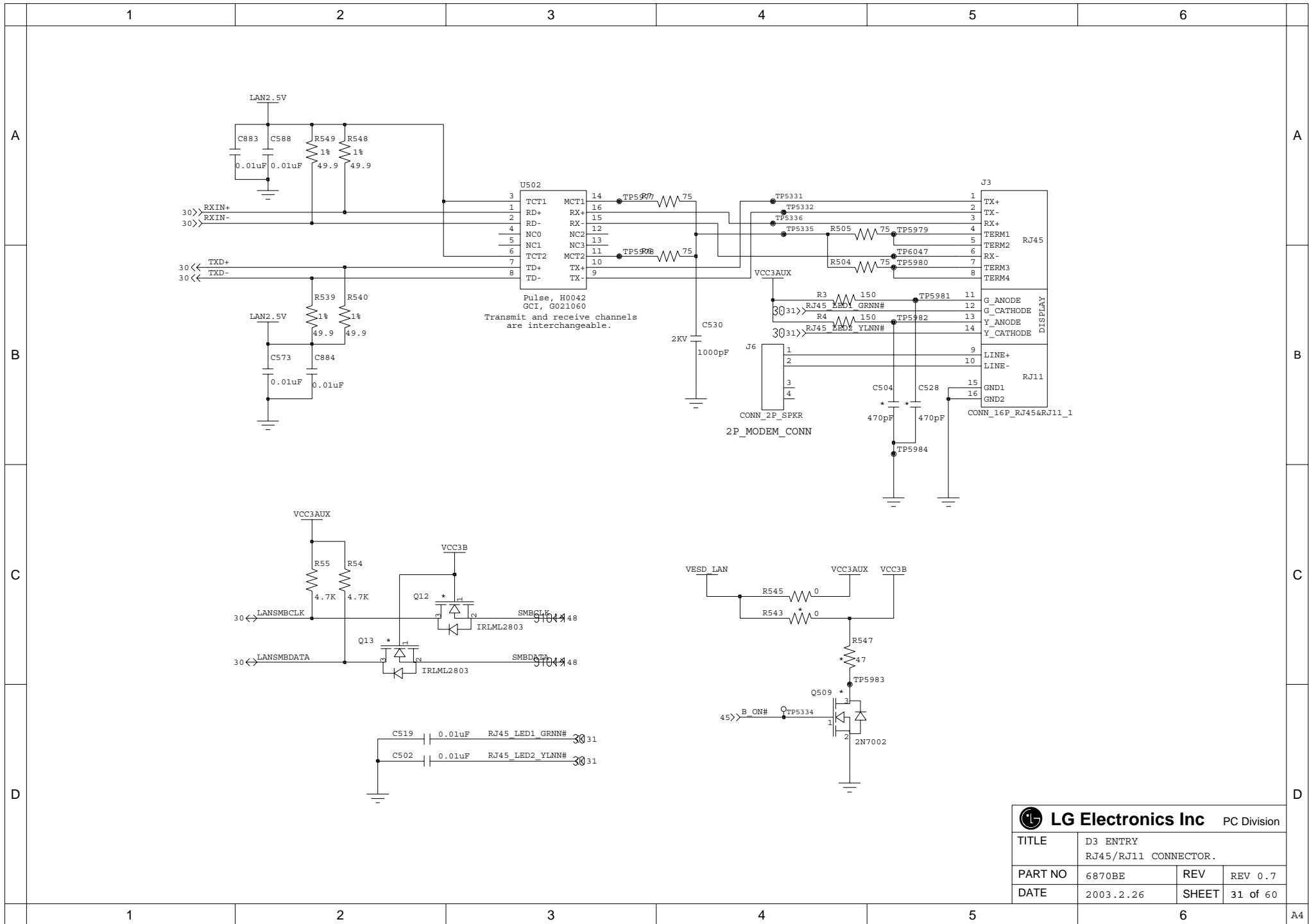

LG Electronics Inc PC Division			
TITLE	D3 ENTRY RJ45/RJ11 CONNECTOR.		
PART NO	6870BE	REV	REV 0.7
DATE	2003.2.26	SHEET	31 of 60

	1	2	3	4	5	6	
A							A
B							B
C							C
D							D
	1	2	3	4	5	6	A4

 LG Electronics Inc PC Division			
TITLE	D3 ENTRY BLANK		
PART NO	6870BE	REV	REV 0.7
DATE	2003.2.26	SHEET	32 of 60

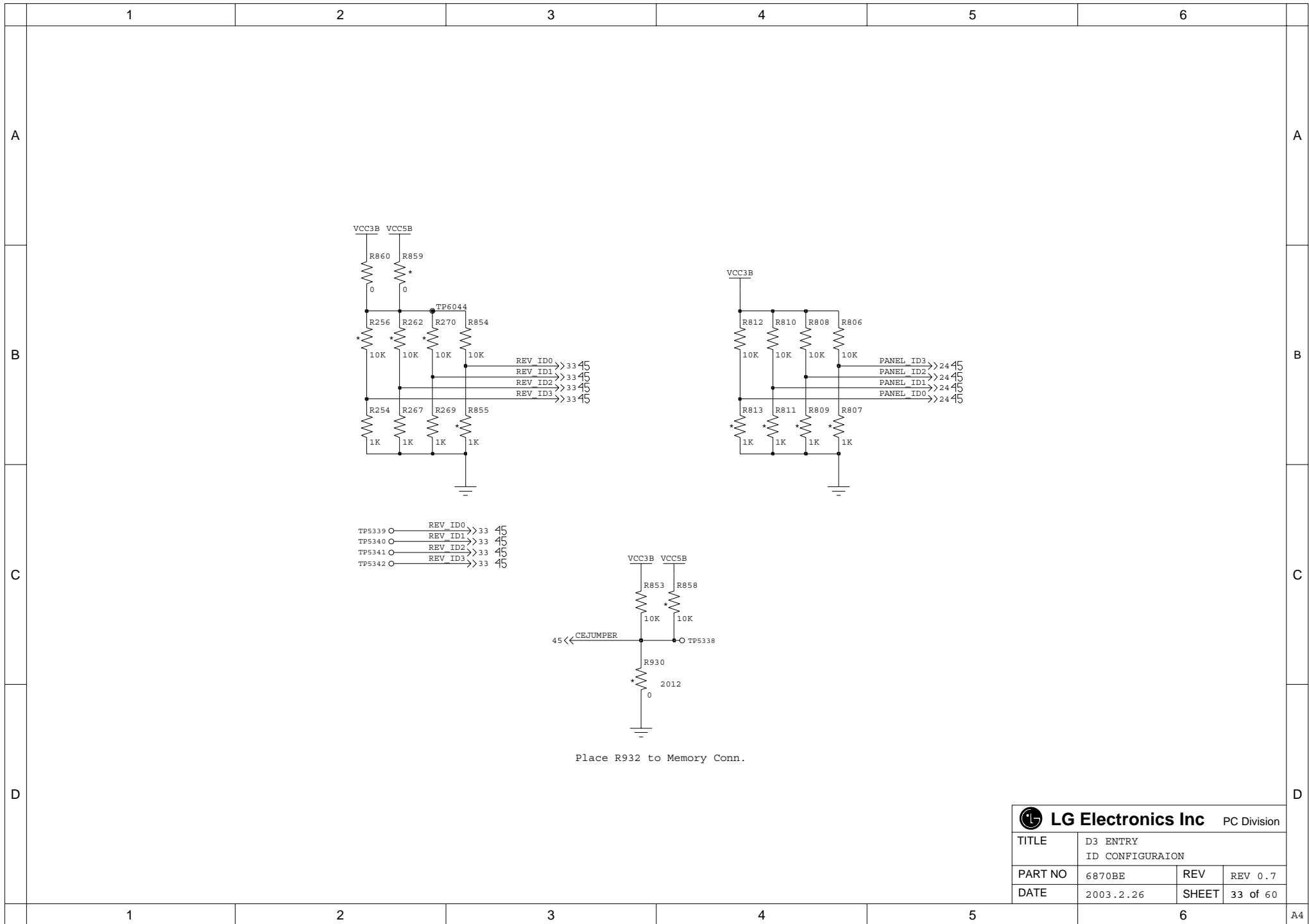

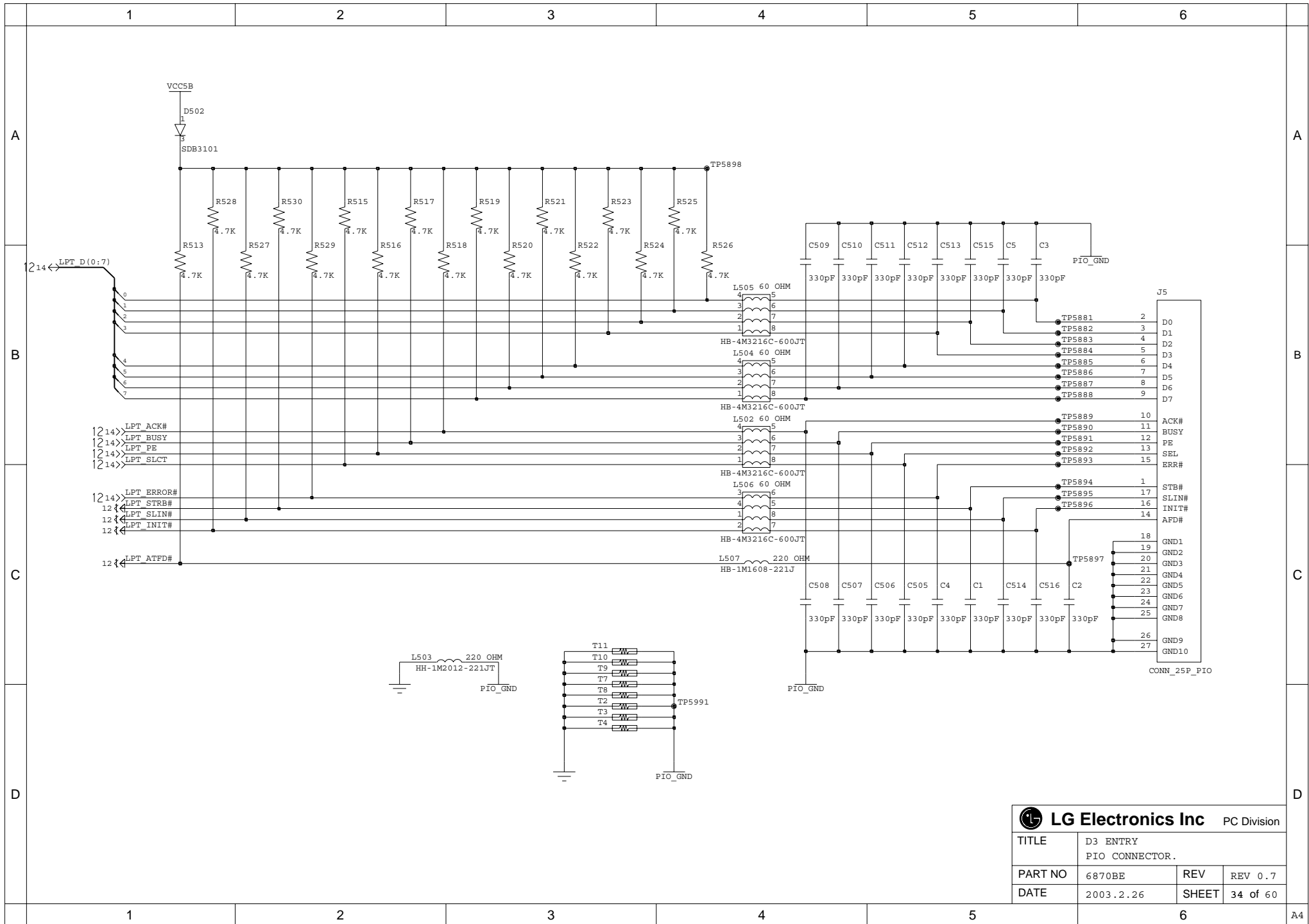

LG Electronics Inc PC Division			
TITLE	D3 ENTRY ID CONFIGURAION		
PART NO	6870BE	REV	REV 0.7
DATE	2003.2.26	SHEET	33 of 60

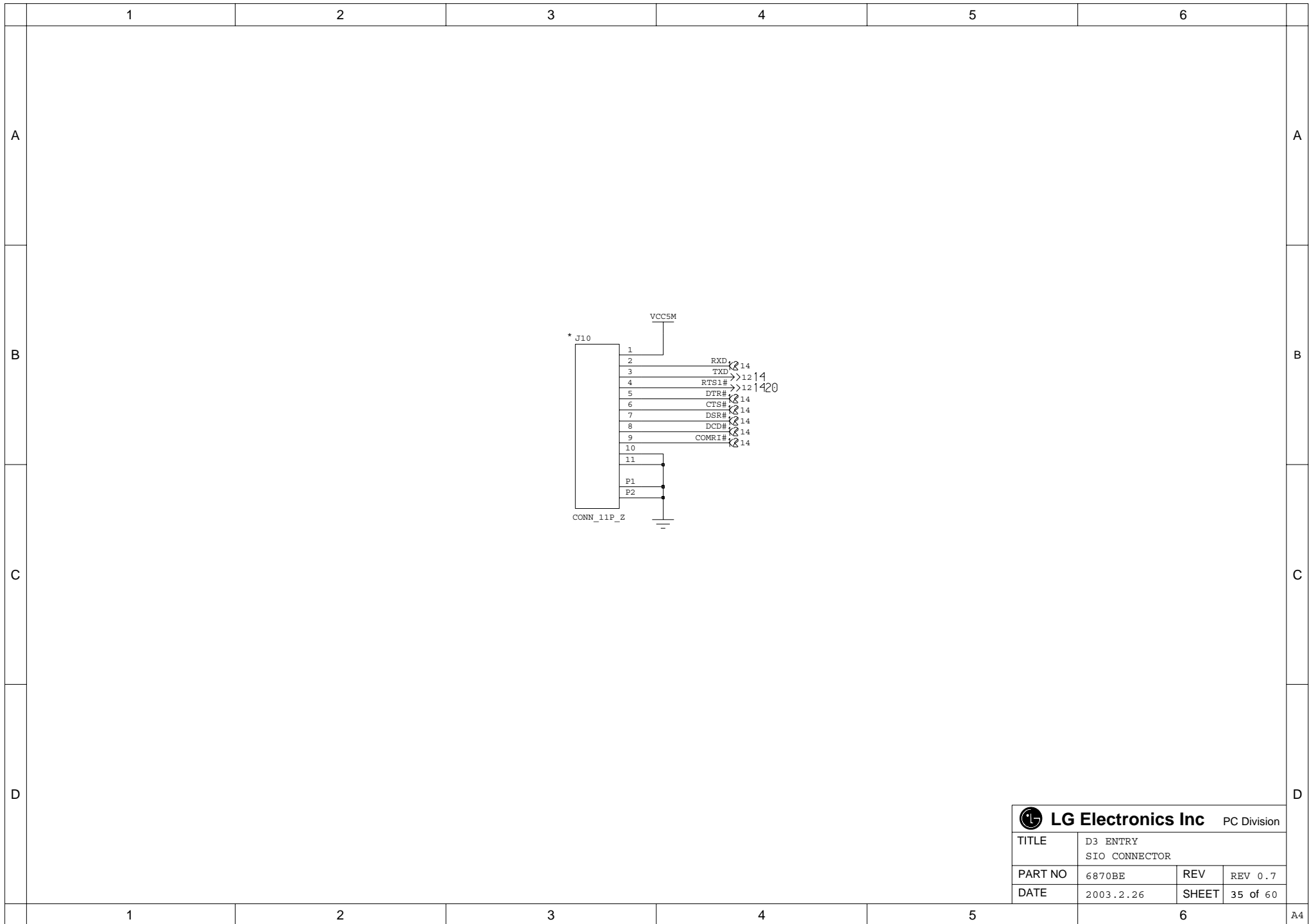

LG Electronics Inc PC Division

TITLE	D3 ENTRY PIO CONNECTOR.		
PART NO	6870BE	REV	REV 0.7
DATE	2003.2.26	SHEET	34 of 60



 LG Electronics Inc PC Division			
TITLE	D3 ENTRY SIO CONNECTOR		
PART NO	6870BE	REV	REV 0.7
DATE	2003.2.26	SHEET	35 of 60

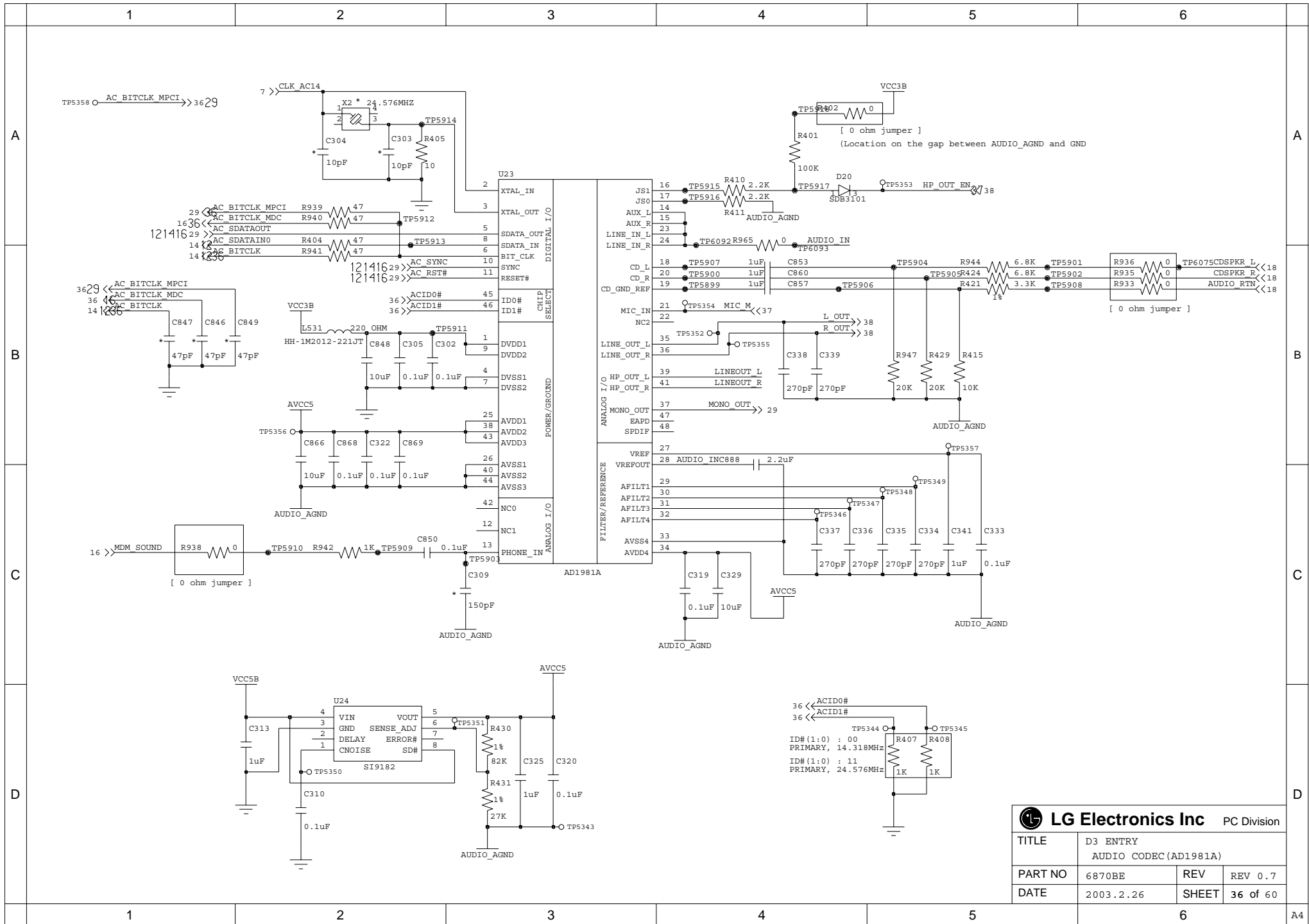

LG Electronics Inc PC Division			
TITLE	D3 ENTRY AUDIO CODEC (AD1981A)		
PART NO	6870BE	REV	REV 0.7
DATE	2003.2.26	SHEET	36 of 60

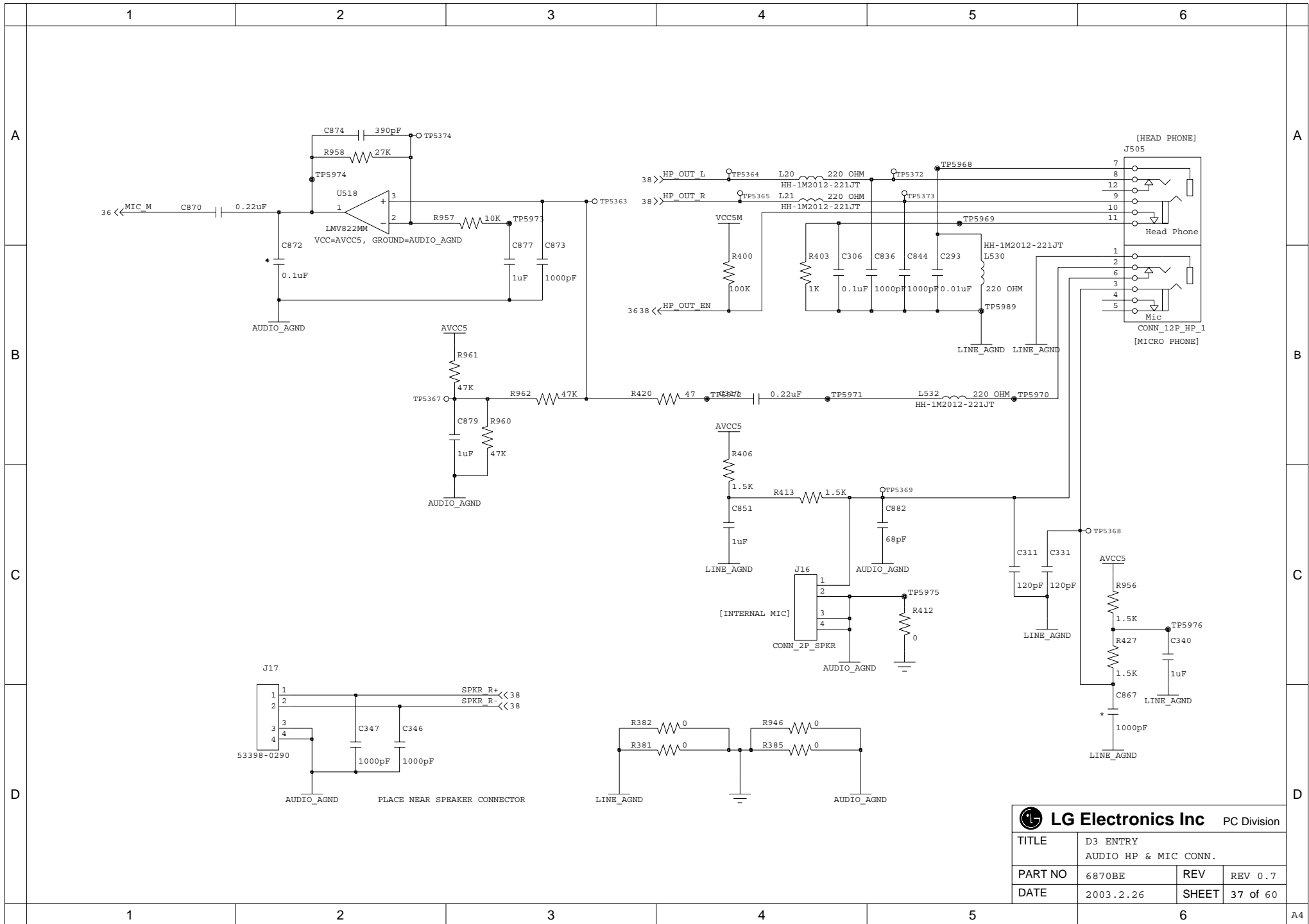

LG Electronics Inc PC Division			
TITLE		D3 ENTRY AUDIO HP & MIC CONN.	
PART NO	6870BE	REV	REV 0.7
DATE	2003.2.26	SHEET	37 of 60

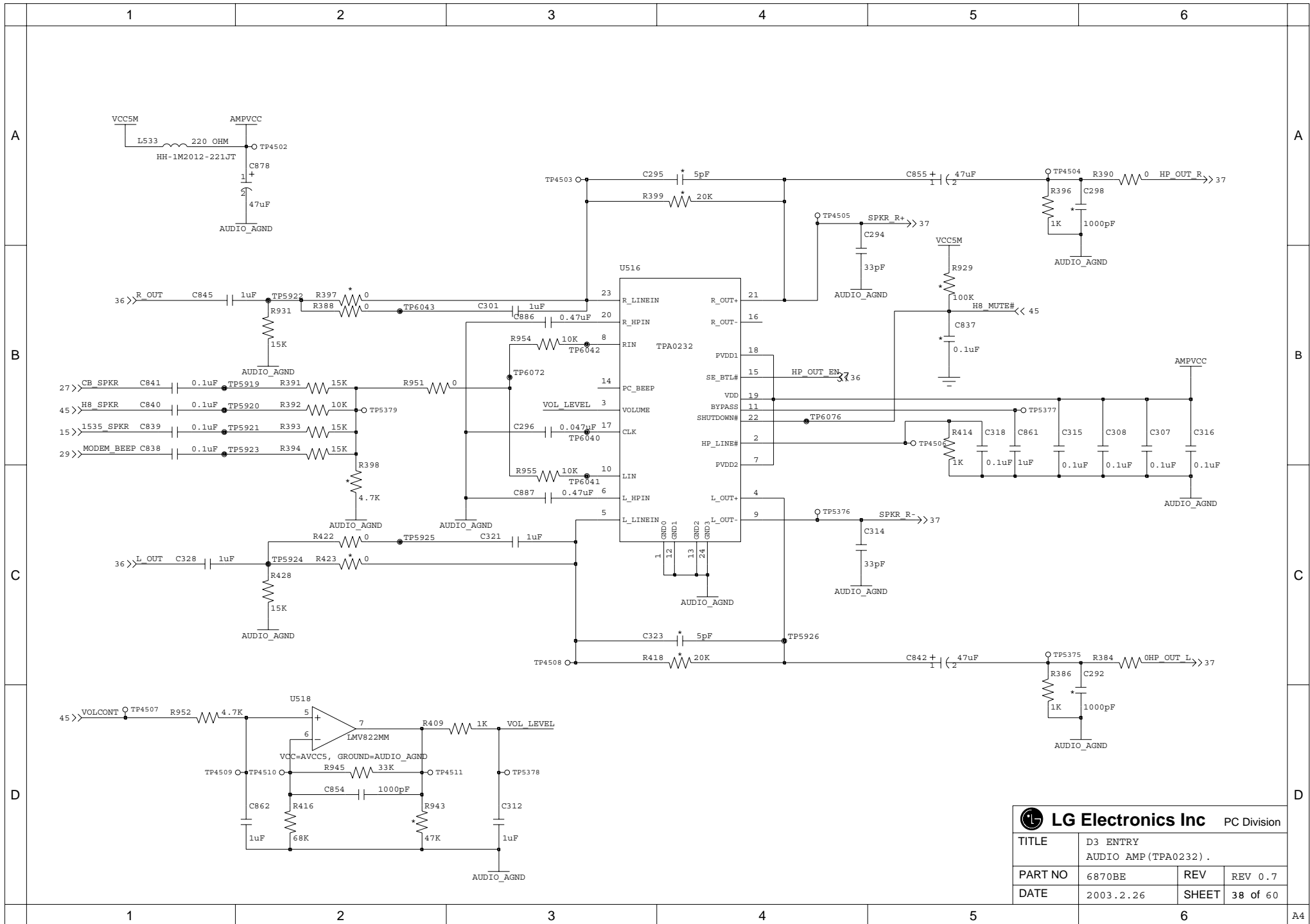

LG Electronics Inc PC Division			
TITLE		D3 ENTRY AUDIO AMP (TPA0232) .	
PART NO	6870BE	REV	REV 0.7
DATE	2003.2.26	SHEET	38 of 60

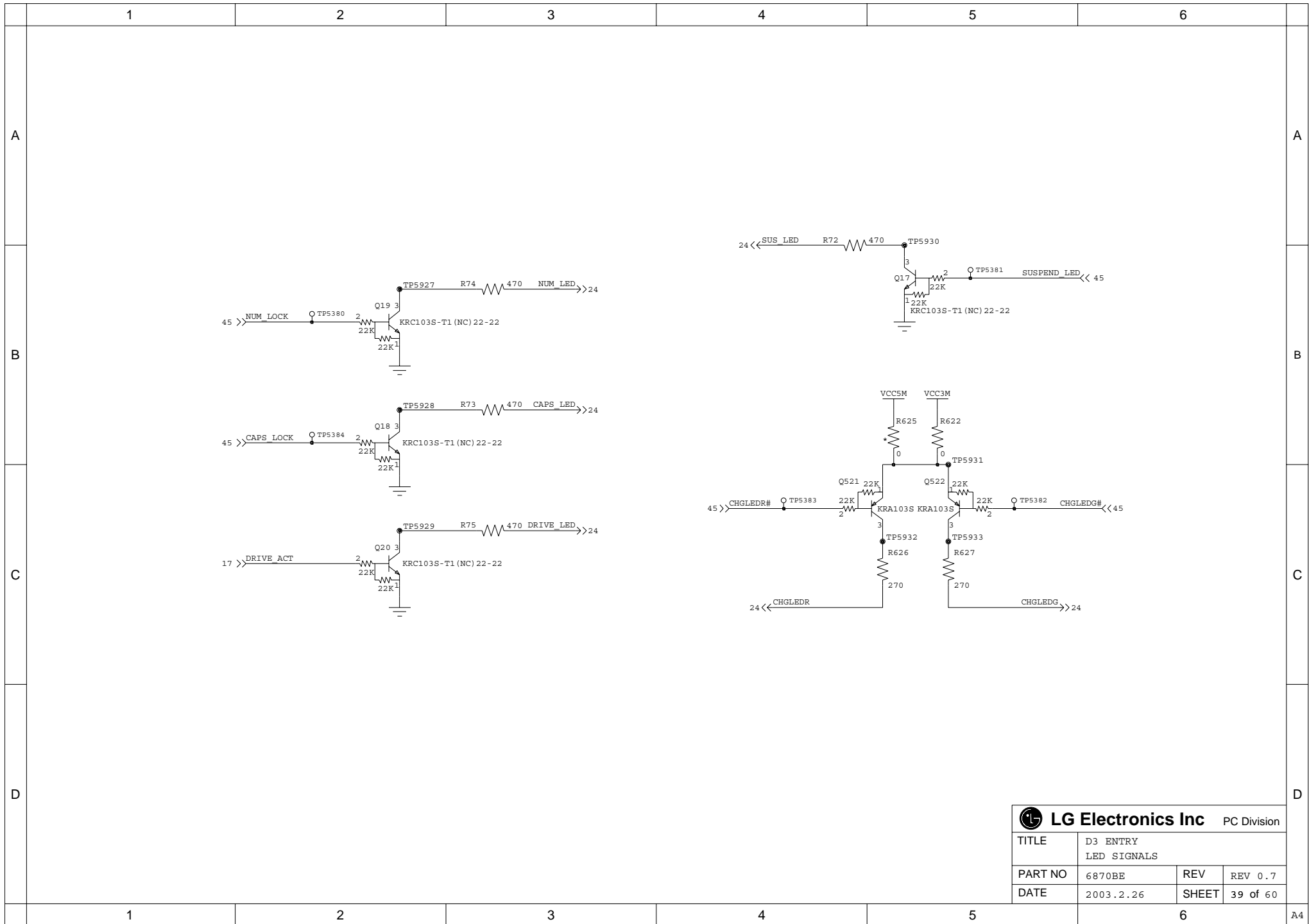

LG Electronics Inc PC Division			
TITLE	D3 ENTRY LED SIGNALS		
PART NO	6870BE	REV	REV 0.7
DATE	2003.2.26	SHEET	39 of 60

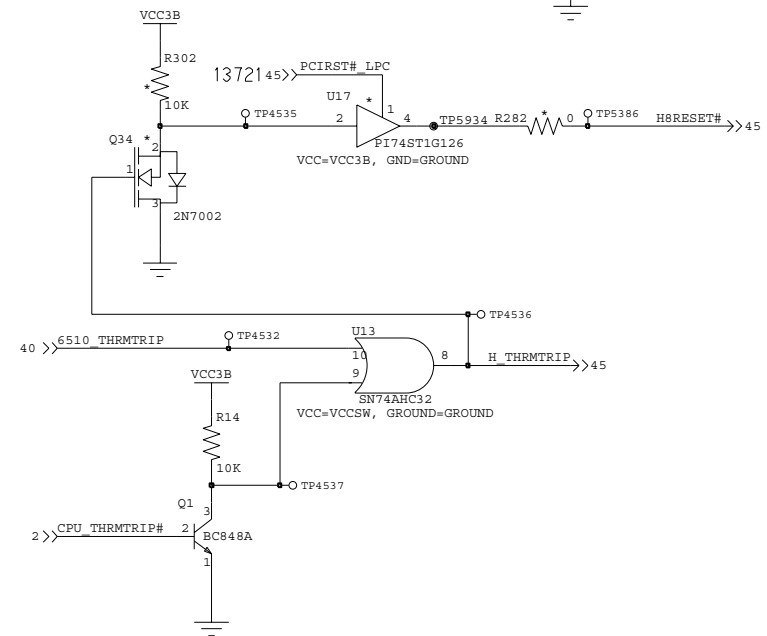
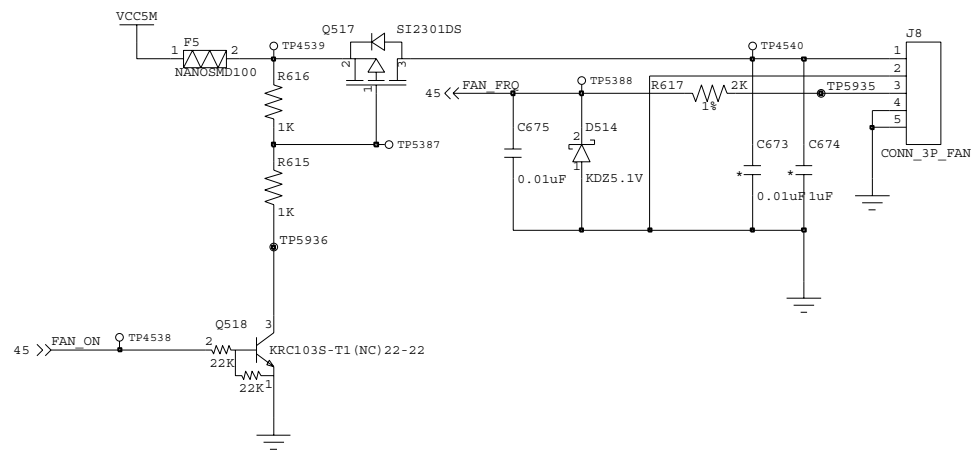
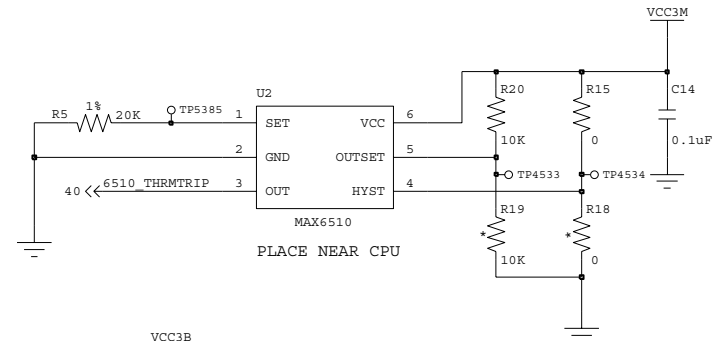
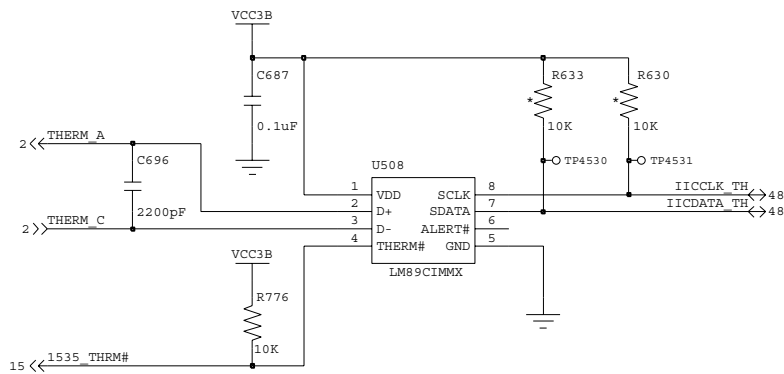

LG Electronics Inc PC Division			
TITLE	D3 ENTRY THERMAL SENSOR & FAN CONNECTOR		
PART NO	6870BE	REV	REV 0.7
DATE	2003.2.26	SHEET	40 of 60

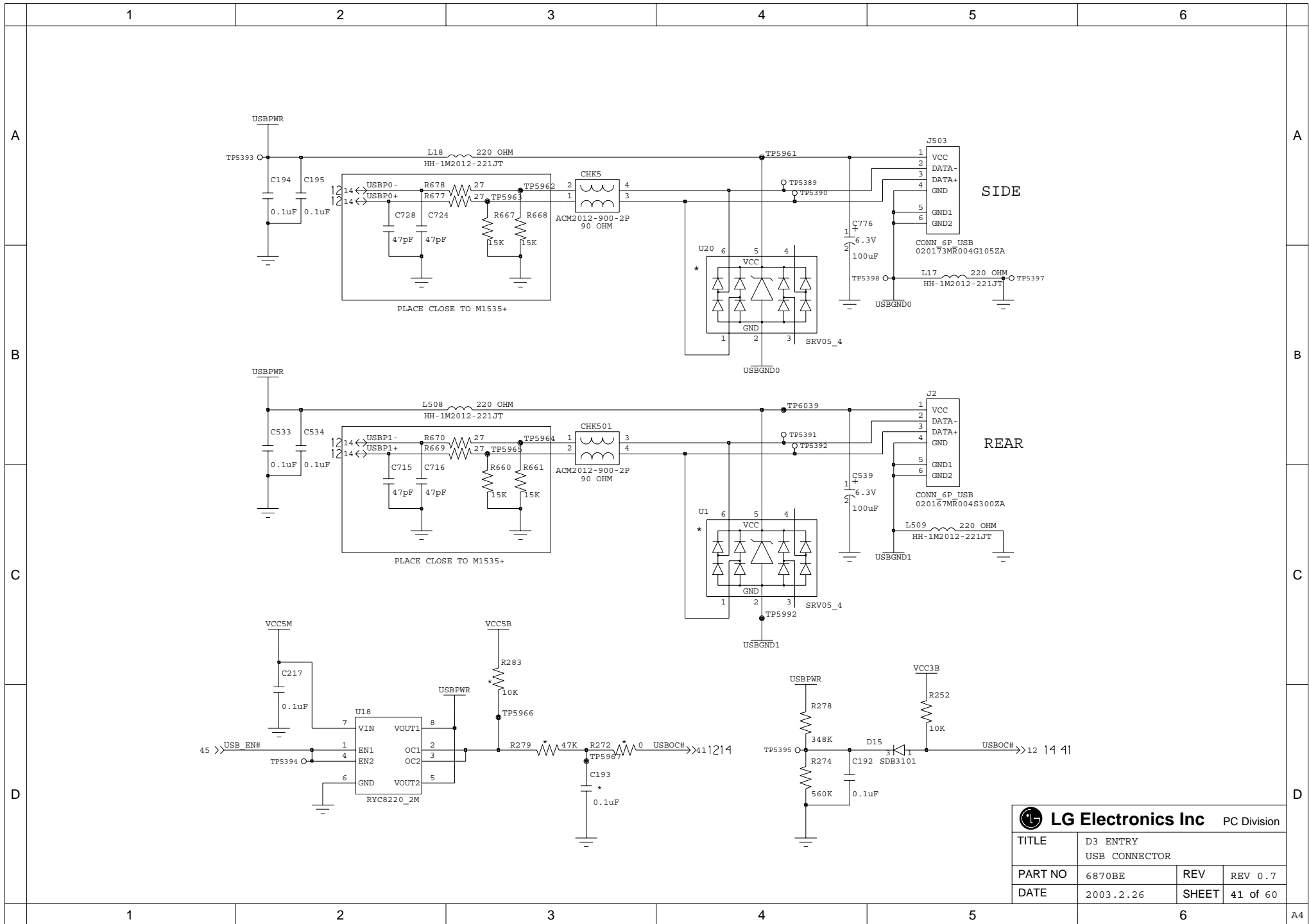

LG Electronics Inc PC Division

TITLE	D3 ENTRY USB CONNECTOR		
PART NO	6870BE	REV	REV 0.7
DATE	2003.2.26	SHEET	41 of 60

	1	2	3	4	5	6	
A							A
B							B
C							C
D							D
	1	2	3	4	5	6	A4

 LG Electronics Inc PC Division			
TITLE	D3 ENTRY BLANK		
PART NO	6870BE	REV	REV 0.7
DATE	2003.2.26	SHEET	42 of 60

	1	2	3	4	5	6	
A							A
B							B
C							C
D							D
	1	2	3	4	5	6	A4

 LG Electronics Inc PC Division			
TITLE	D3 ENTRY BLANK		
PART NO	6870BE	REV	REV 0.7
DATE	2003.2.26	SHEET	43 of 60

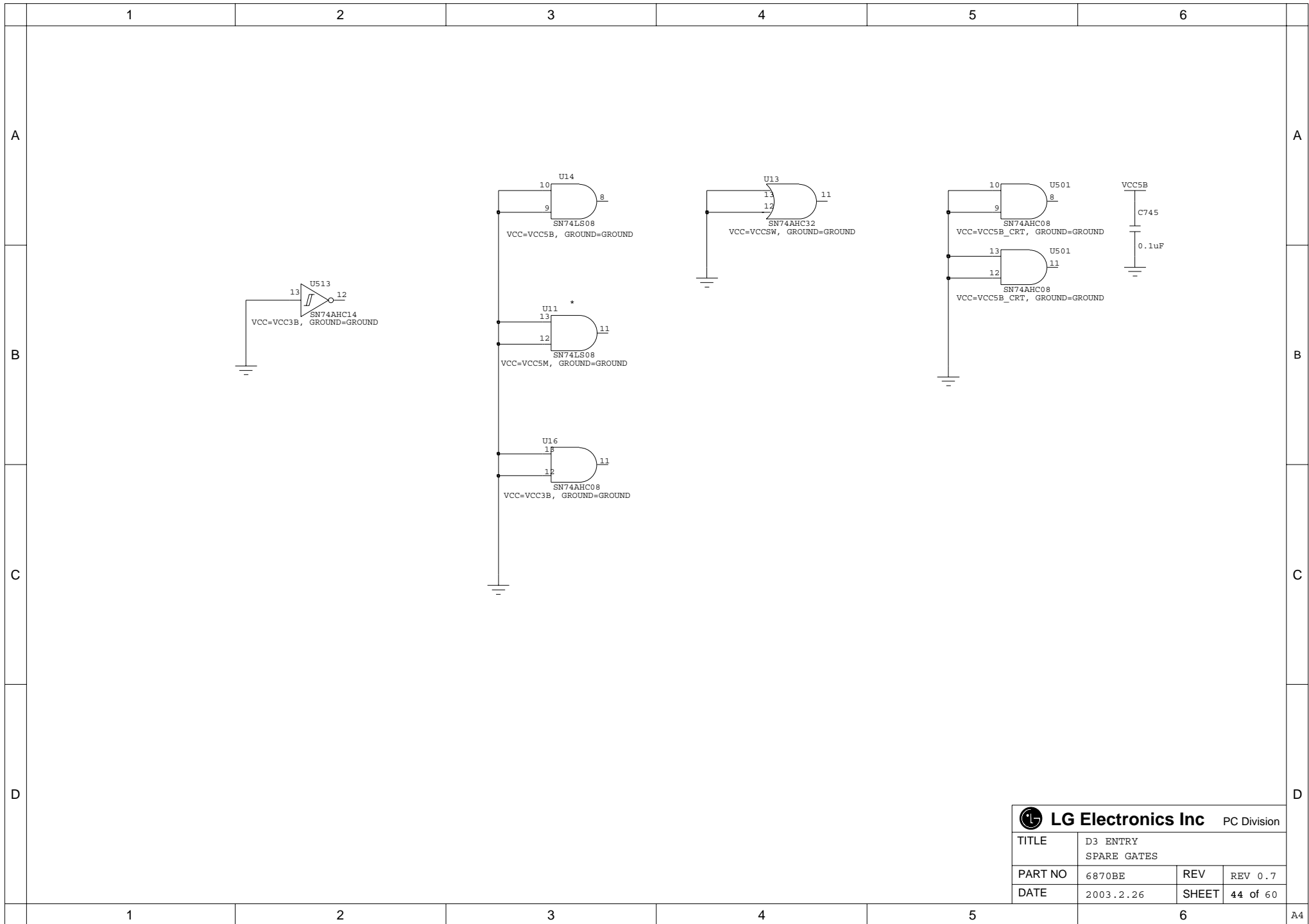

 LG Electronics Inc PC Division			
TITLE	D3 ENTRY SPARE GATES		
PART NO	6870BE	REV	REV 0.7
DATE	2003.2.26	SHEET	44 of 60

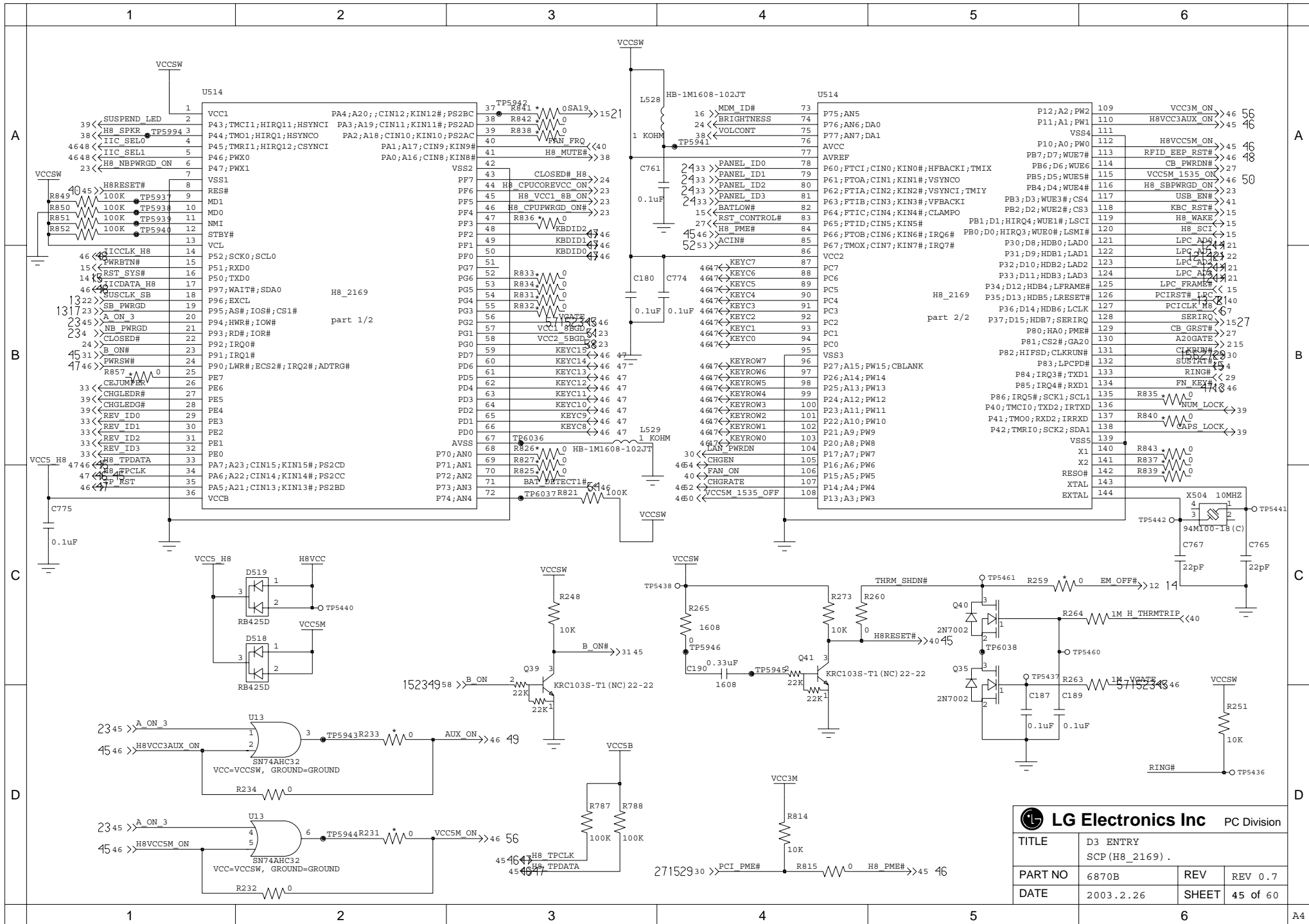

LG Electronics Inc PC Division			
TITLE	D3 ENTRY SCP (H8_2169) .		
PART NO	6870B	REV	REV 0.7
DATE	2003.2.26	SHEET	45 of 60

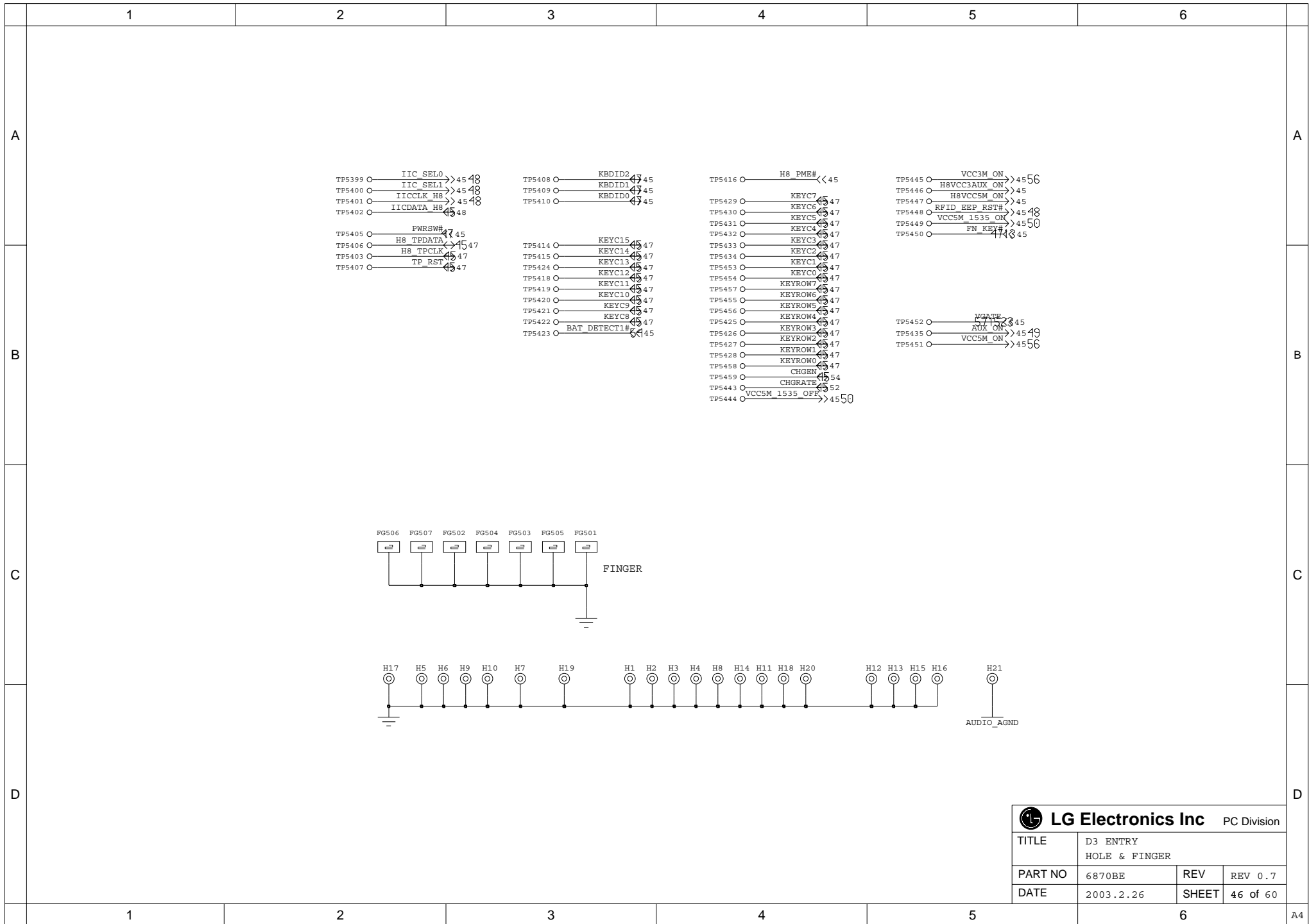

LG Electronics Inc PC Division			
TITLE	D3 ENTRY HOLE & FINGER		
PART NO	6870BE	REV	REV 0.7
DATE	2003.2.26	SHEET	46 of 60

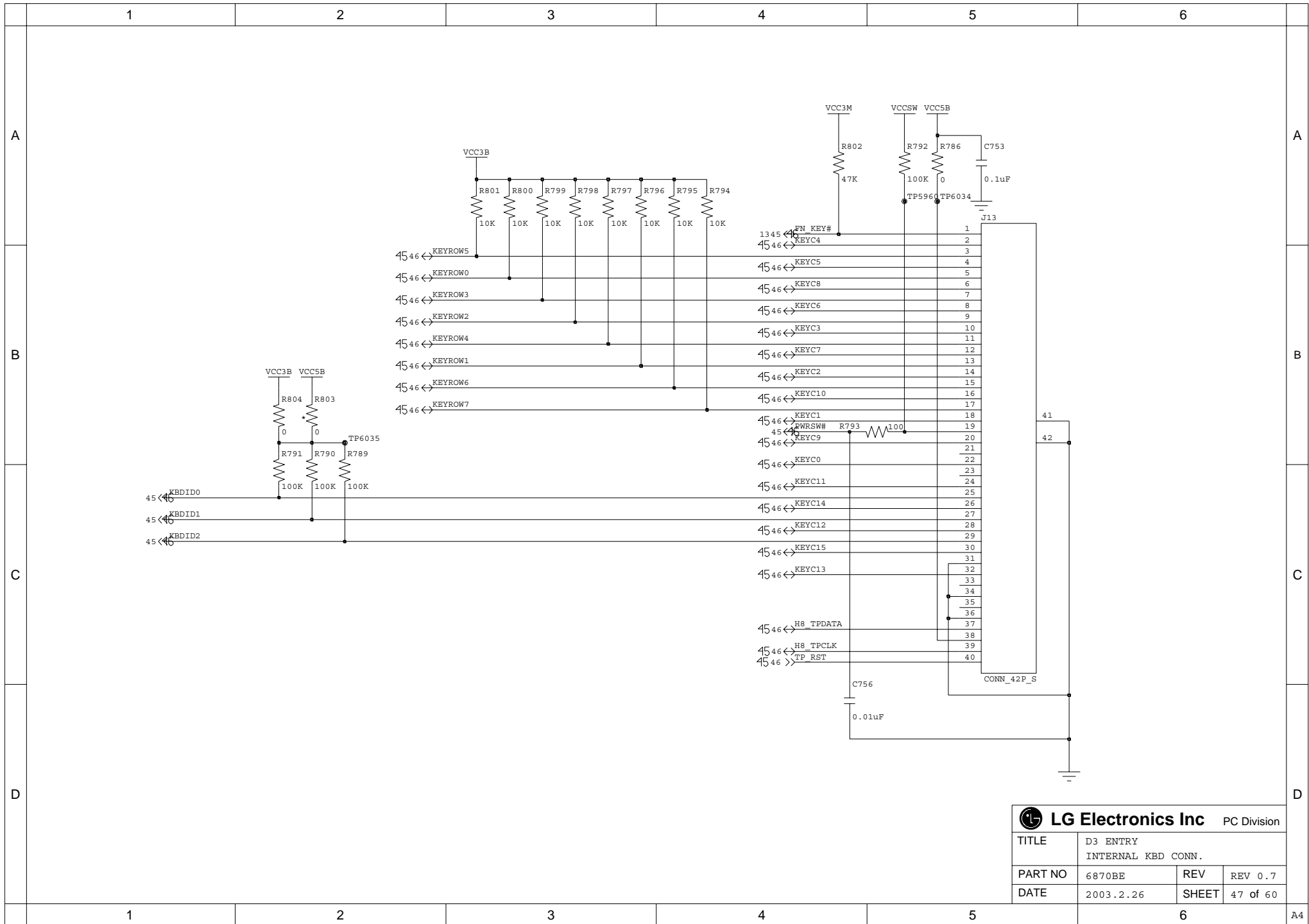

LG Electronics Inc PC Division			
TITLE	D3 ENTRY INTERNAL KBD CONN.		
PART NO	6870BE	REV	REV 0.7
DATE	2003.2.26	SHEET	47 of 60

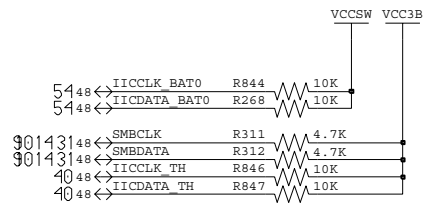
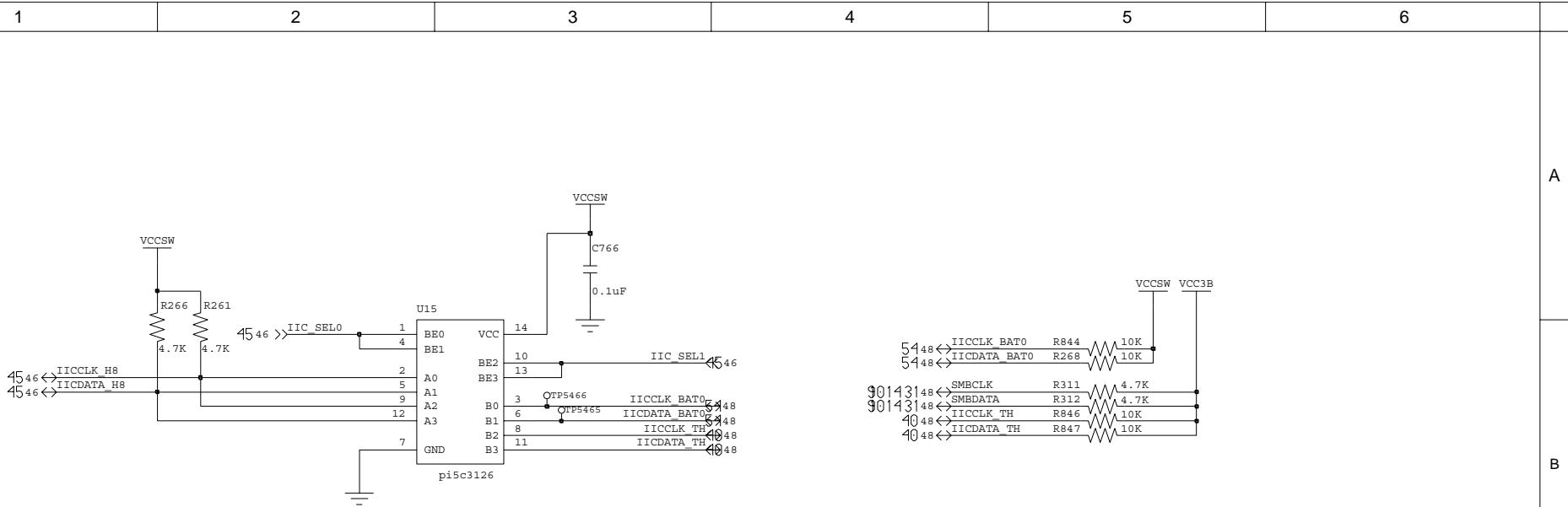

SEL0	SEL1	IICCLK_H8	IICDATA_H8
LOW	LOW	ISOLATE	ISOLATE
HIGH	LOW	IICCLK_BAT0	IICDATA_BAT0
LOW	HIGH	IICCLK_TH	IICDATA_TH

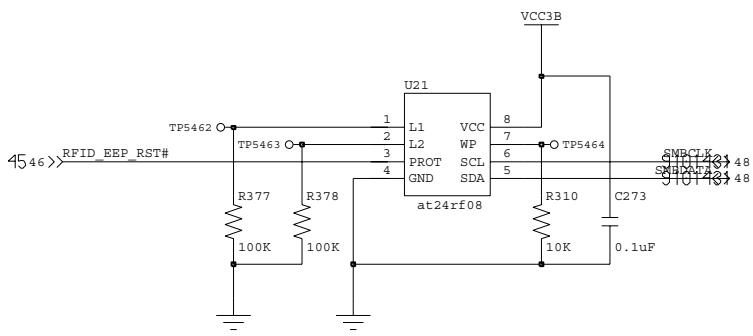

LG Electronics Inc PC Division			
TITLE	D3 ENTRY SMBUS & RFID.		
PART NO	6870BE	REV	REV 0.7
DATE	2003.2.26	SHEET	48 of 60

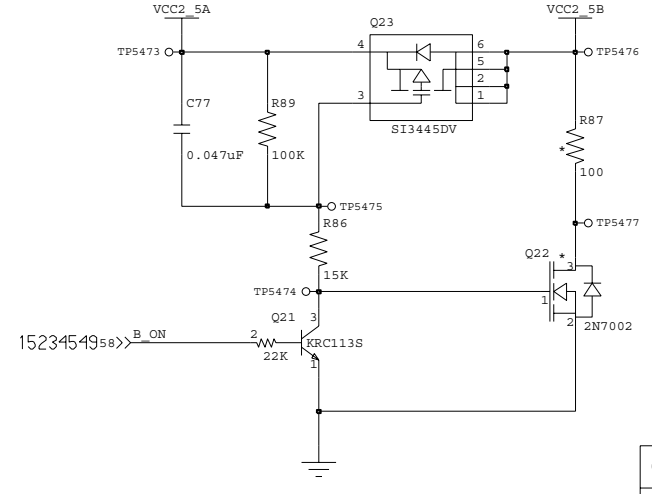
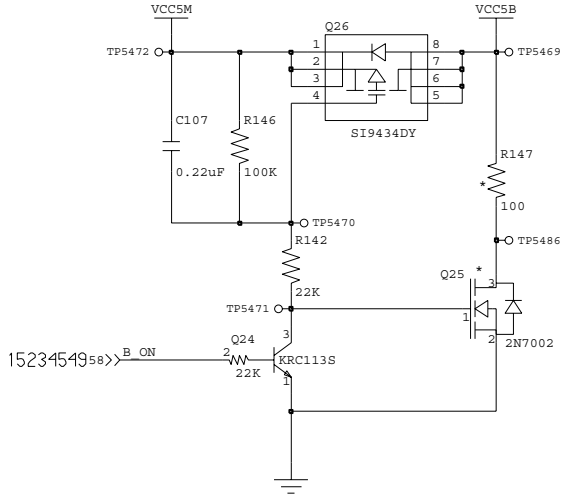
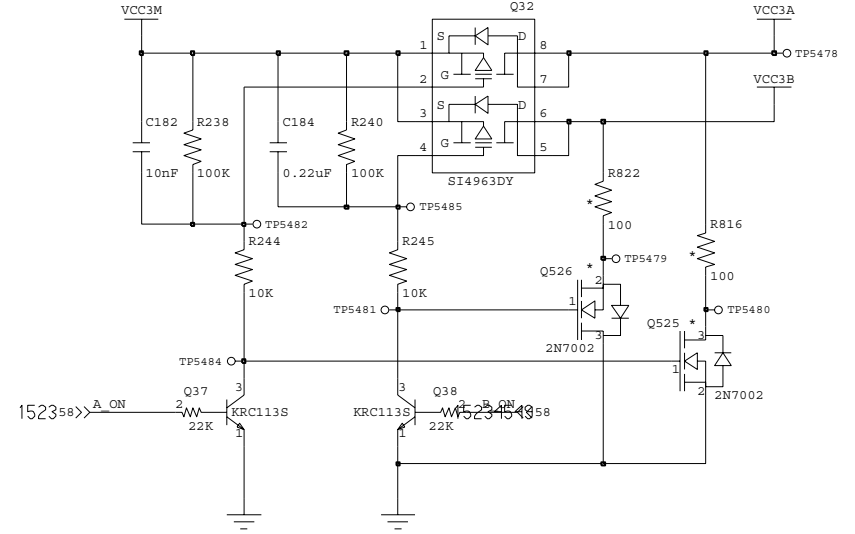
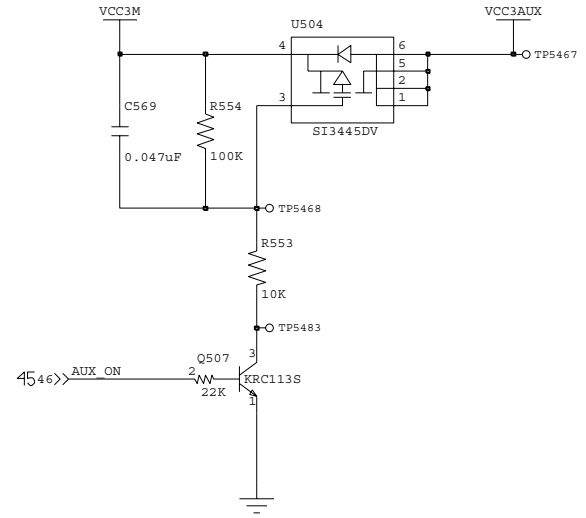

LG Electronics Inc PC Division			
TITLE	D3 ENTRY SYSTEM DCDC-I		
PART NO	6870BE	REV	REV 0.7
DATE	2003.2.26	SHEET	49 of 60

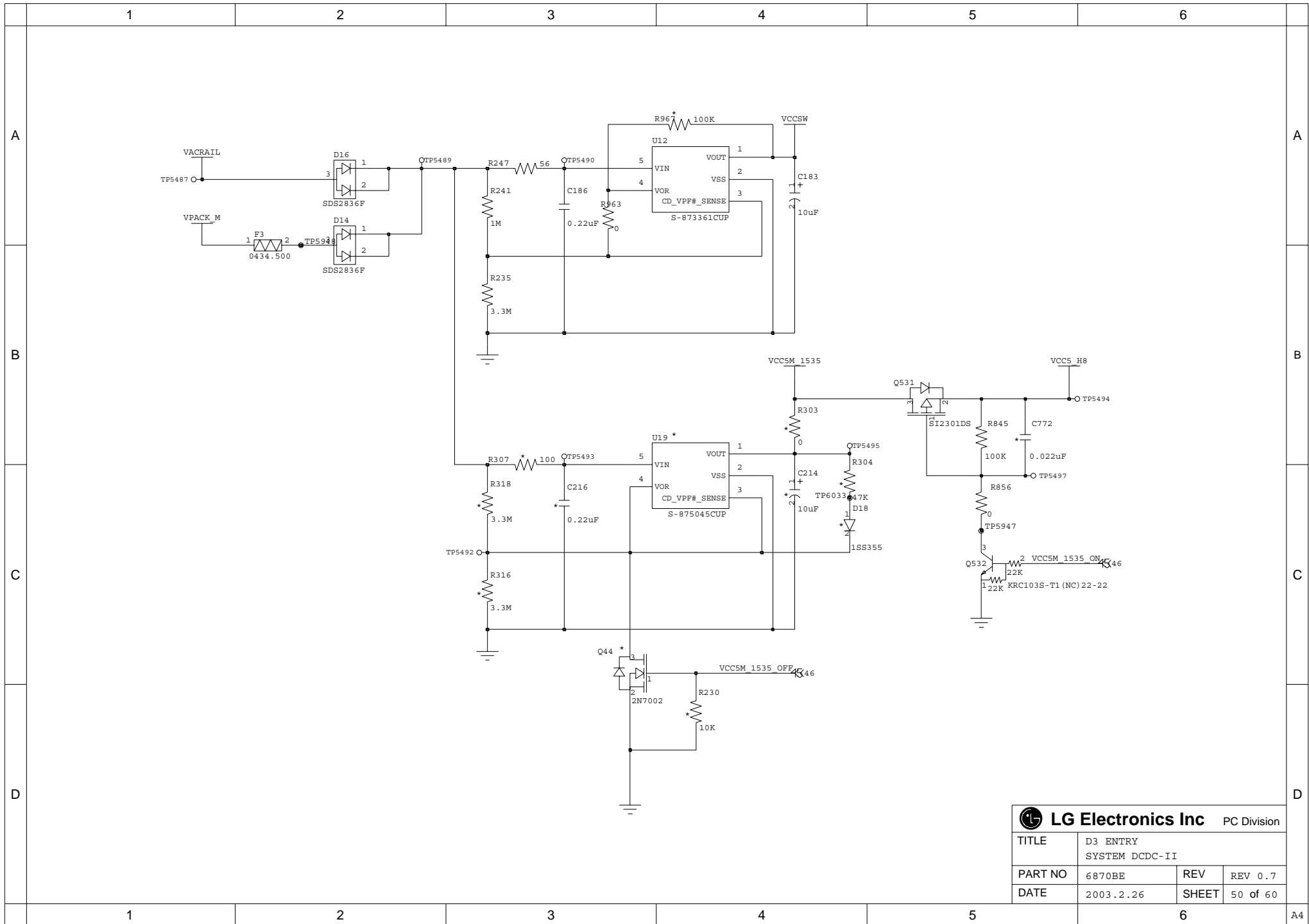

LG Electronics Inc PC Division			
TITLE	D3 ENTRY SYSTEM DCDC-II		
PART NO	6870BE	REV	REV 0.7
DATE	2003.2.26	SHEET	50 of 60

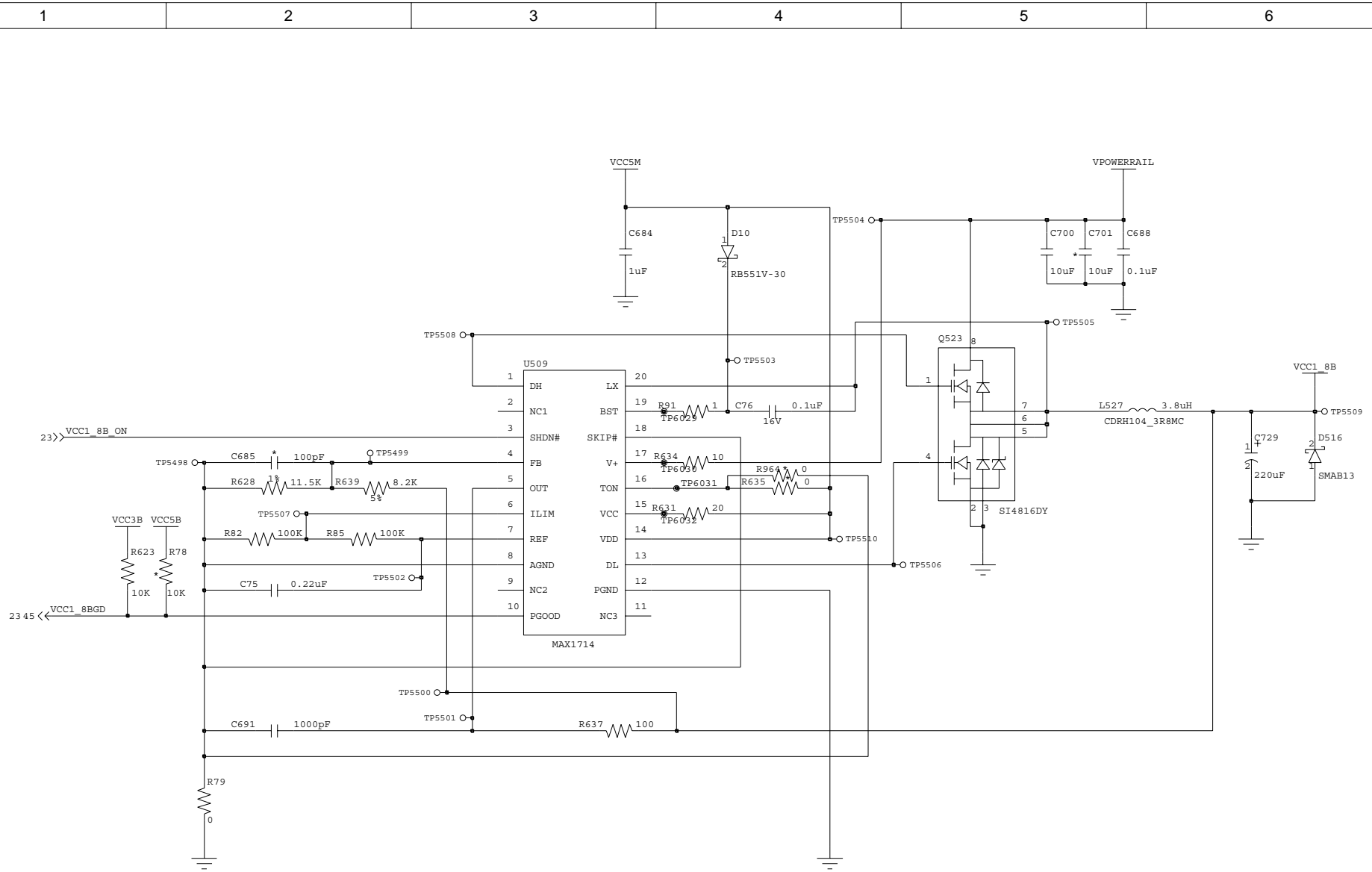

 LG Electronics Inc PC Division			
TITLE	D3 ENTRY SYSTEM DCDC-III.		
PART NO	6871B	REV	REV 0.7
DATE	2003.2.26	SHEET	51 of 60

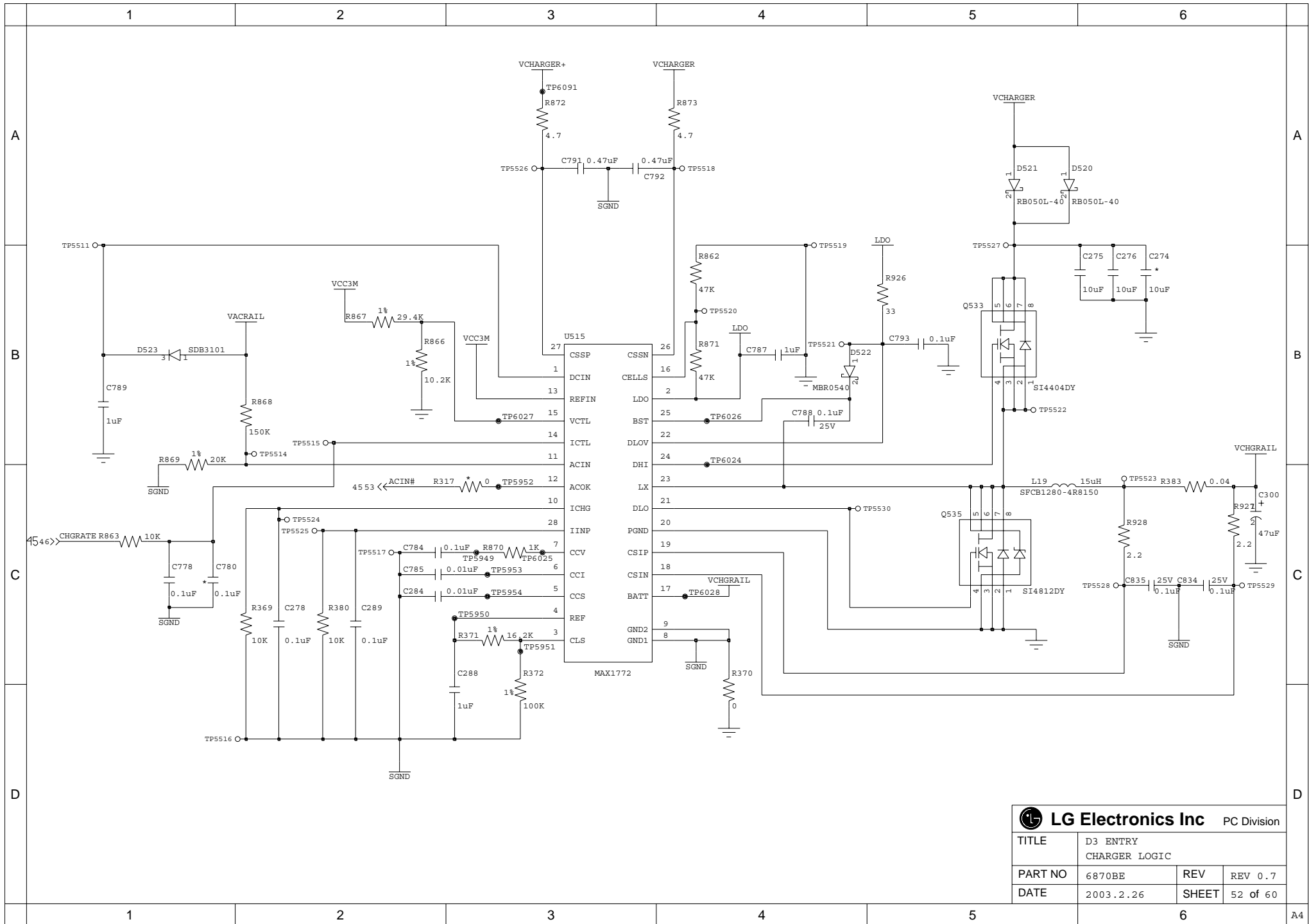

LG Electronics Inc PC Division			
TITLE		D3 ENTRY CHARGER LOGIC	
PART NO	6870BE	REV	REV 0.7
DATE	2003.2.26	SHEET	52 of 60

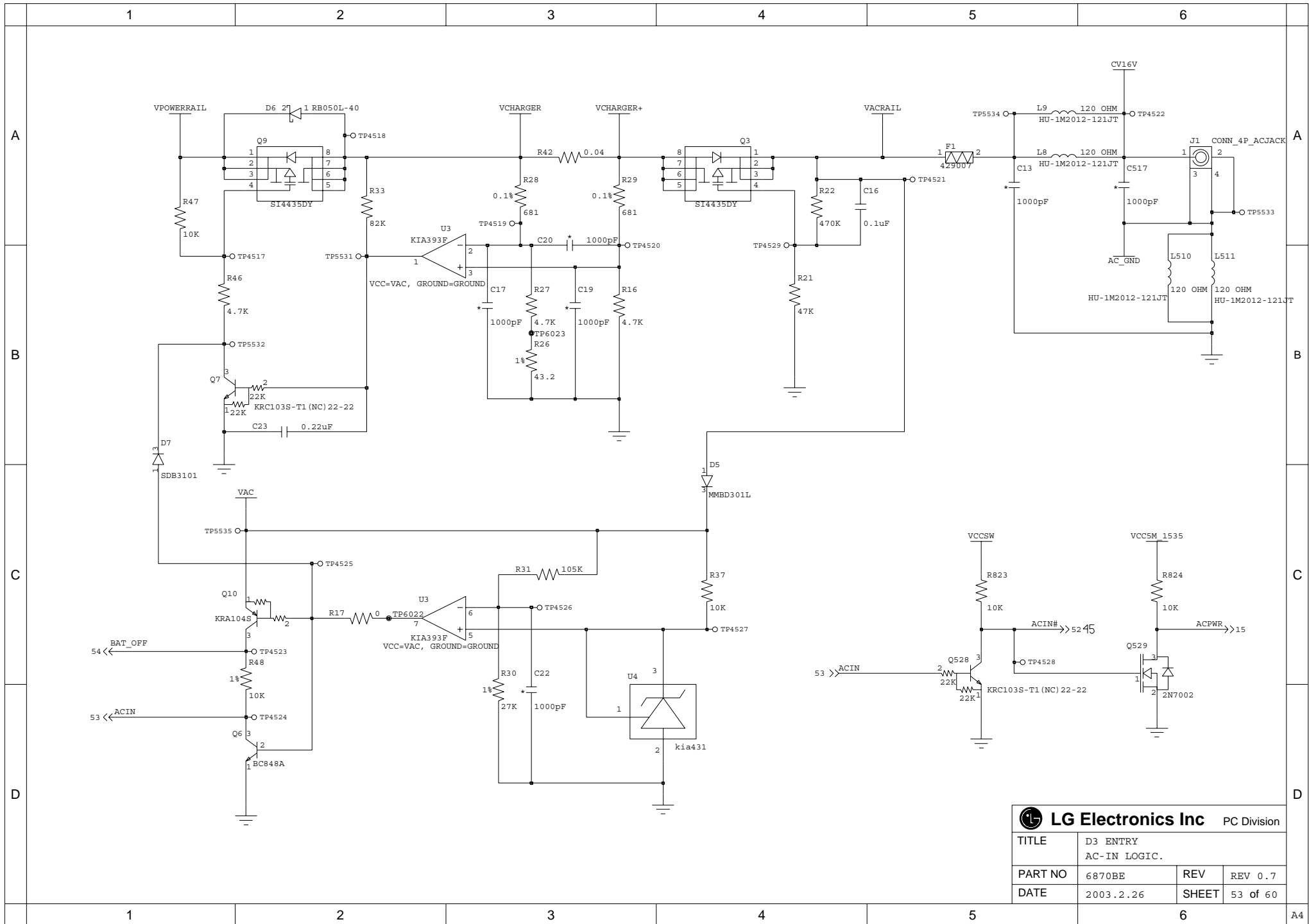

LG Electronics Inc PC Division			
TITLE		D3 ENTRY AC-IN LOGIC.	
PART NO	6870BE	REV	REV 0.7
DATE	2003.2.26	SHEET	53 of 60

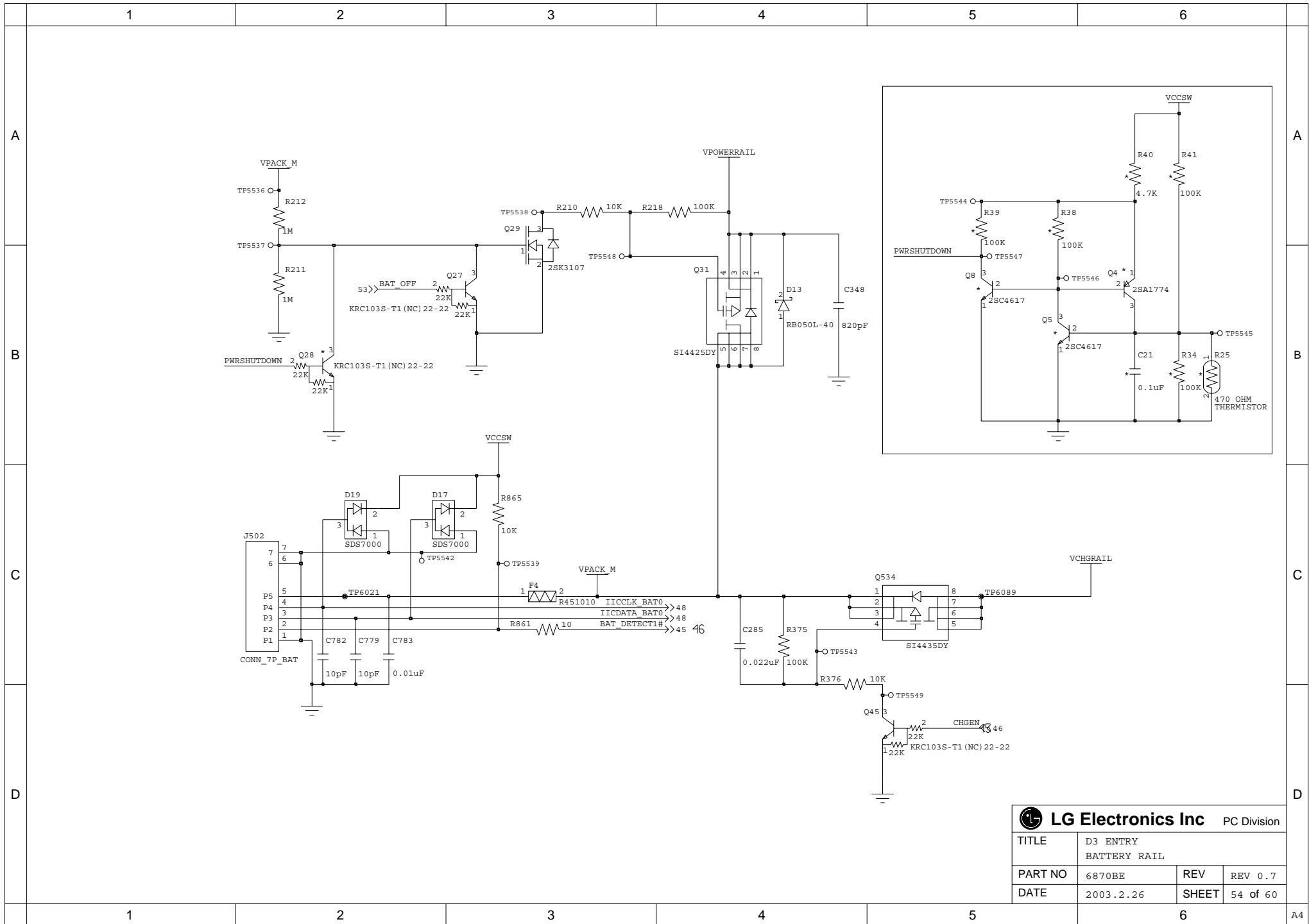

LG Electronics Inc PC Division

TITLE	D3 ENTRY BATTERY RAIL		
PART NO	6870BE	REV	REV 0.7
DATE	2003.2.26	SHEET	54 of 60

	1	2	3	4	5	6	
A							A
B							B
C							C
D							D
	1	2	3	4	5	6	A4

 LG Electronics Inc PC Division			
TITLE	D3 ENTRY BLANK		
PART NO	6870BE	REV	REV 0.7
DATE	2003.2.26	SHEET	55 of 60

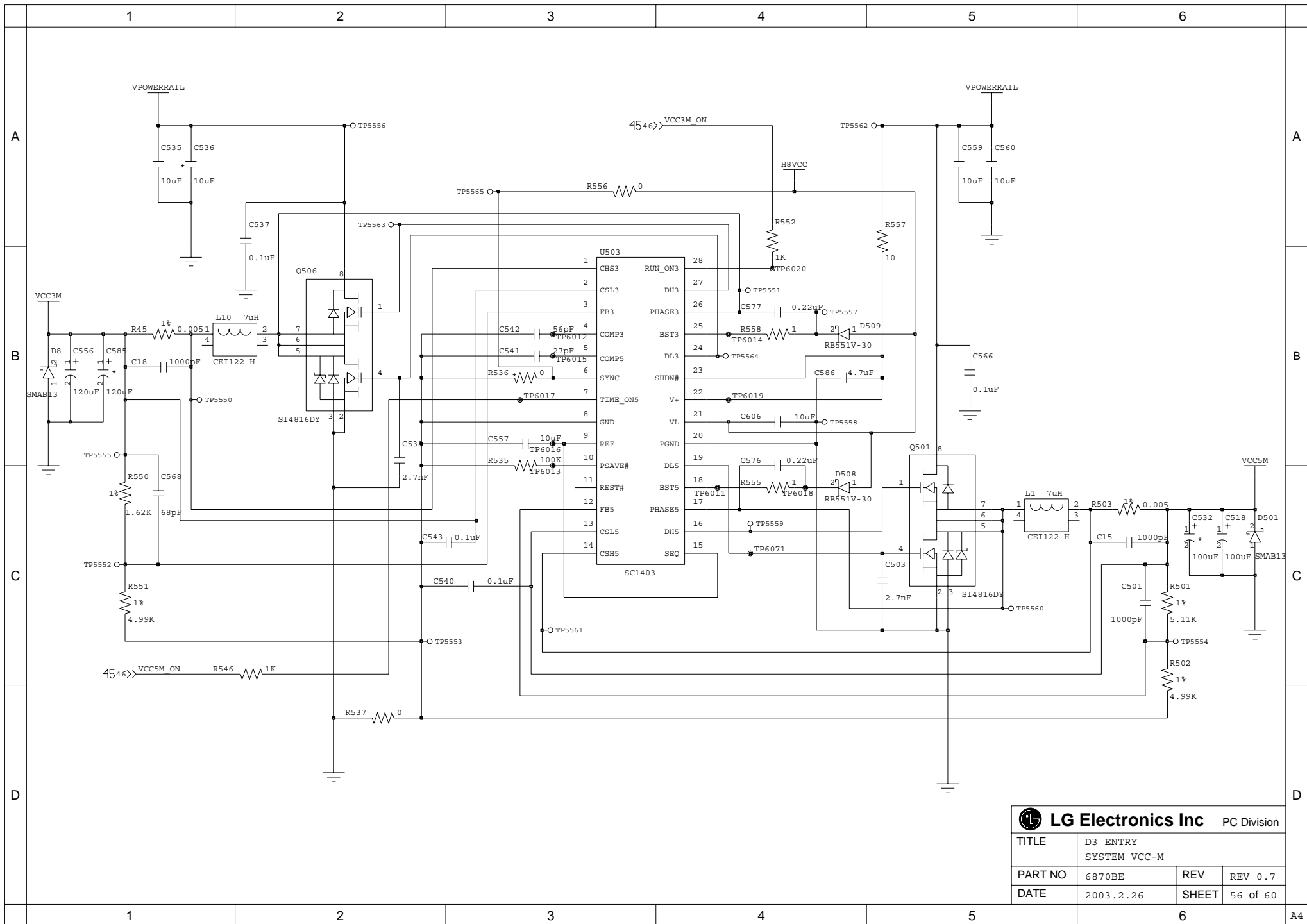

LG Electronics Inc PC Division			
TITLE	D3 ENTRY SYSTEM VCC-M		
PART NO	6870BE	REV	REV 0.7
DATE	2003.2.26	SHEET	56 of 60

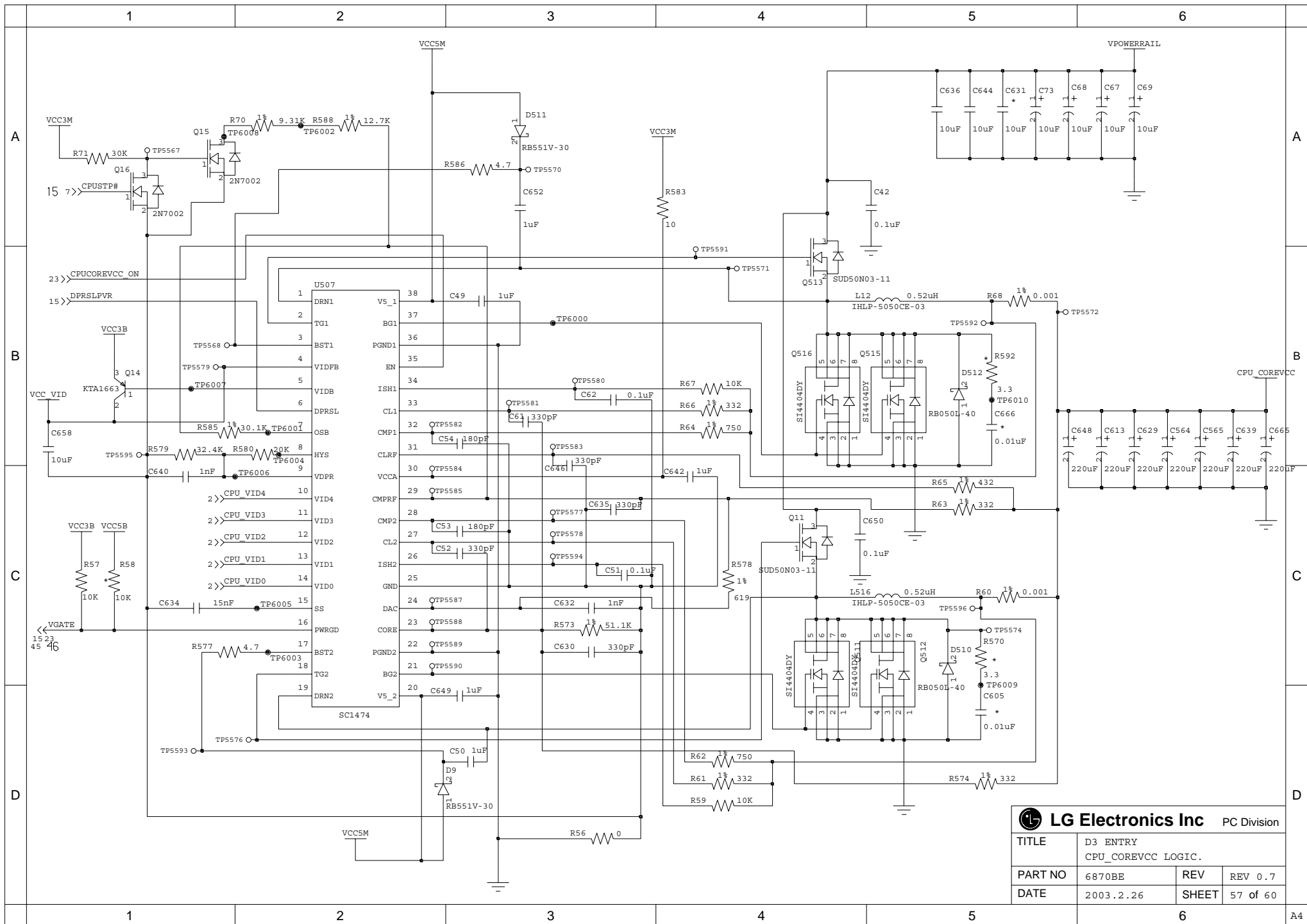

LG Electronics Inc PC Division			
TITLE	D3 ENTRY CPU_COREVCC LOGIC.		
PART NO	6870BE	REV	REV 0.7
DATE	2003.2.26	SHEET	57 of 60

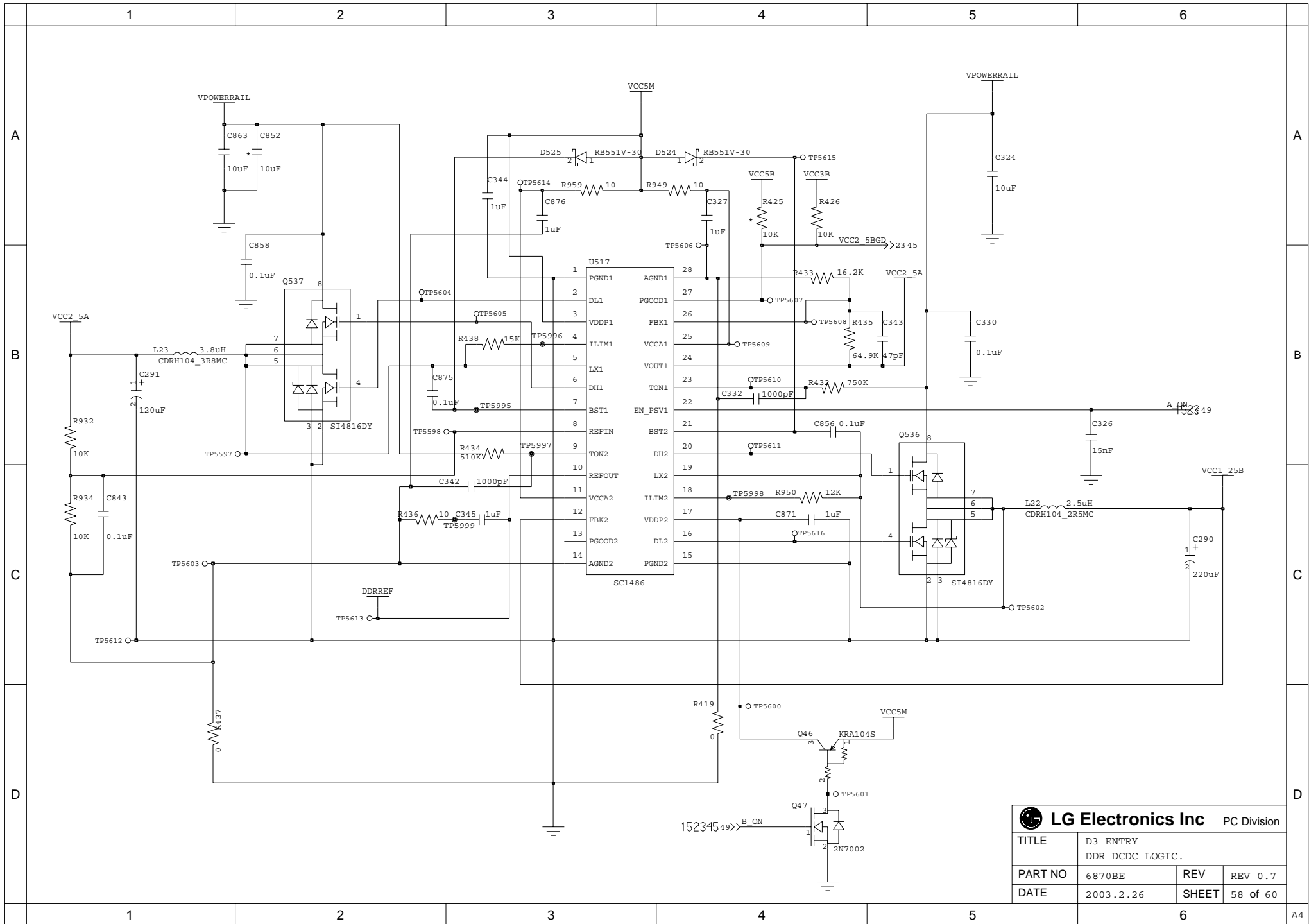

LG Electronics Inc PC Division

TITLE	D3 ENTRY DDR DCDC LOGIC.		
PART NO	6870BE	REV	REV 0.7
DATE	2003.2.26	SHEET	58 of 60

D3 ENTRY (P4) BLOCK DIAGRAM

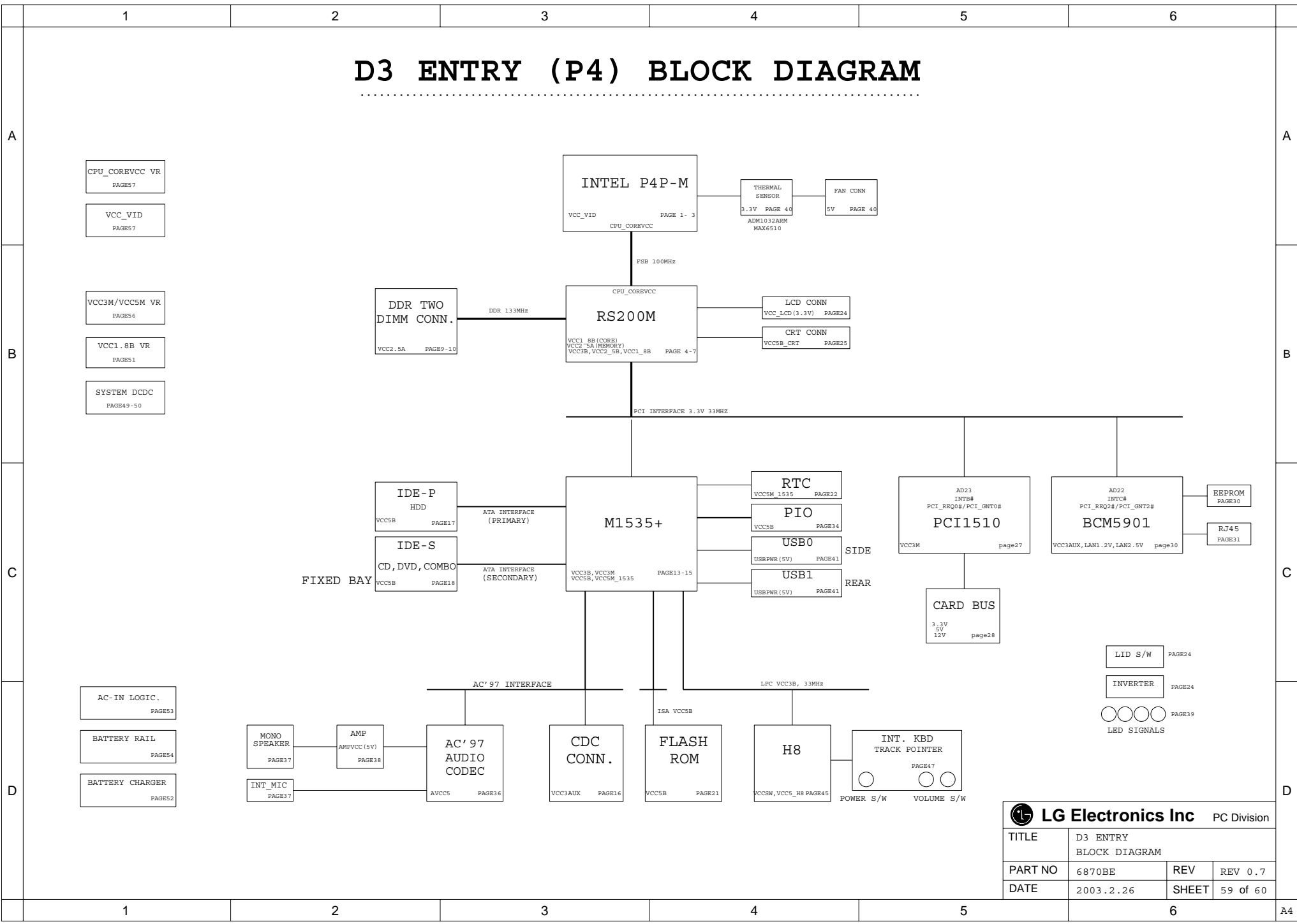

LG Electronics Inc PC Division			
TITLE	D3 ENTRY BLOCK DIAGRAM		
PART NO	6870BE	REV	REV 0.7
DATE	2003.2.26	SHEET	59 of 60

Revision History

Revision	Page	Description	Revision	Page	Description
0.2	9,10	Change from 1 dimm to 2 dimm.			
	21	Flash Rom change from FWH to ISA type.			
	24	HOTARU logic is added.			
	30	Lan Controller change from 3COM to Broadcom.			

A

A

B

B

C

C

D

D

 LG Electronics Inc		PC Division	
TITLE	D3 ENTRY REVISION HISTORY.		
PART NO	6870BE	REV	REV 0.7
DATE	2003.2.26	SHEET	60 of 60